

# Development of Local Energy Consumption Monitoring System

Ansis Avotins (*Doctoral Student, Riga Technical University – RTU*), Peter Apse-Apsitis (*Researcher, RTU*),  
Maris Kunickis (*Doctoral Student, RTU*), Leonids Ribickis (*Professor, RTU*)

**Abstract** – This research deals with investigation of different consumer equipment electrical characteristics. Equipment of three different households are measured and analyzed. Further a current sensor technology was chosen and consumption measurement methodology and algorithm were developed. Five consumption measurement devices for local energy monitoring system were developed and tested on different type consumers simultaneously in laboratory environment. For data storage, calculation and transmission, low power, high performance 8/16-bit AVR microcontroller ATxMega 16A4U and 433MHz low-cost RFM22B ISM FSK transceiver module was chosen.

**Keywords** – Smart grids, smart homes, electric variables measurement, computerized monitoring, energy efficiency.

## I. INTRODUCTION

Measurement and monitoring of electrical energy consumption enables economical relationship between consumer and electricity supplier. During the last decades lots of different mechanical and digital electric power meters were developed, that still are used and available on the market, typically varying by their application field, determined by the phase number, load current and voltage level and consumption profile, as well as applied measurement method and precision.

During the last years, a new term “smart grid” has been defined and described in several documents of EU Commission (EC) and U.S. Department of Energy (DOE), as well as other specialized institutions. In the EU documents it is stated that “Smart Grids are electricity networks that can efficiently integrate the behavior and actions of all users connected to it — generators, consumers and those that do both — in order to ensure an economically efficient, sustainable power system with low losses and high quality and security of supply and safety” [1][2]. Such definition places focus on economical aspects. Another explanations are quite common in different informative sources, coming from DOE documents [3], where smart grid is defined as “an automated, widely distributed energy delivery network characterized by a two-way flow of electricity and information, capable of monitoring and responding to changes in everything from power plants to customer preferences to individual appliances” or “a smart grid is the electricity delivery system (from point of generation to point of consumption) integrated with communications and information technology”. These explanations are placing focus on reliability. It can be justified in accordance with [4], the United States in 2007 has higher system average interruption duration index and system

average interruption frequency index than leading European Countries, like Germany, UK, Denmark, France etc.

Existing power grids are mainly using automation system based on the operational principles developed decades ago, and it already has elements that are providing full or partial functionality of smart grid. As the global policy and market trends are forcing implementation of renewable energy sources, especially wind and solar, that put higher requirements on power balancing, as they have non-predictable energy generation. Therefore traditional centralized control and communication system needs to be improved in order to achieve decentralized control and higher implementation of renewable energy sources [5].

As the smart grid enabling technologies are still evolving, we cannot predict what possible solutions, definitions and new elements it could bring, like hybrid grid systems with both – AC and DC grids in different power levels. Also a new term the “nanogrid” or n-grid has been introduced in [6], as already existing electrical energy distribution network - low energy grids, typically DC, which is not considered a part of the power delivery system, but such networks exist as telecom systems that typically deliver 48 VDC to standard telephones, CAT5e Ethernet networks that deliver Power over Ethernet (POE+) at ~50-57 VDC to networked devices, USB-powered devices, vehicle networks, and others.

This brings us towards a conclusion that in future grids will be a huge demand for different type and functionality smart meters, and in order to decrease energy consumption at average household level, a low-cost metering devices [8] will be necessary, to achieve investment payoffs.

## II. STARTING CONDITIONS

### A. Existing situation in Latvia

Latvia is a small country with small economy, therefore a large investment in smart grid enabling technologies must be justified by payoffs, either installed by energy company or the individual consumer (industrial or household) itself. Also for energy company it is wise to do some test projects, to see how these smart meters work here in real local conditions, and what are the resulting benefits – real savings, where other sources [10] indicate that consumer behavior depends on how he is informed about his consumption, and by using energy-monitors 8,68% are achieved (almost real time data), detailed bills and home pages gave 5% to 6% .

Analyzing data obtained from Latvian Energy Distribution Company AS "Sadales Tikls", there are 1.099 million electric

power meters installed in the distribution grid. Legal clients can be equipped with simple/traditional meters (records consumption in one or several tariff zones, the meter is without interface for remote reading of data), or smart electric power meters (records both daily and monthly consumption by tariff zones, logs load profiles, records events (voltage outages, unauthorized removal of the cover of the meter mechanism, etc.) in the journal, records the instantaneous values and has a communication interface for remote data reading. Overview of installed electric power meters is given in table (see Table I.).

TABLE I  
NUMBER OF INSTALLED METERS

Type of electric power meter	Count, pcs	% from total
Single phase induction type	646 794	59%
Electronic single-phase, simple	132 671	12%
Three phase induction type	232 243	21%
Electronic three-phase, simple	76 157	7%
Three-phase smart electricity meters	11 713	1%
Total:	1 099 578	100%

Distribution grid is still equipped with meters, made in the Soviet Union, that nowadays are morally and technically outdated, therefore a massive scheduled replacement, starting from mid 90-ties was done, and most of them were changed to more advanced and accurate power meters. According to Latvian law and norms, measuring instruments used commercially, must do periodical re-verification. These costs can be considered as maintenance costs and definitely taken into account, when considering time-plan for changing them to smart meters. According to AS "Sadales Tikls" data about planned counter verifications (see **Error! Reference source not found.**), a year 2015, could be a good start point for replacing existing meters to new smart meters, if according decisions are made.

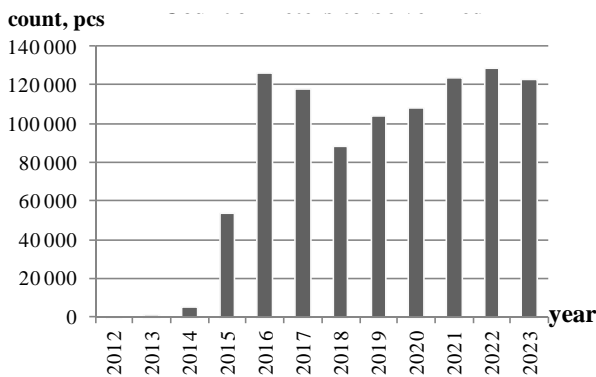

Fig. 1. Count of electric power meters to be verified within next years

The largest amount of power meters are installed on households - 91% from total (see Fig. 2.), legal entities takes just 9% from total number, where just 1% of power meters installed provides access to automated power consumption reading system (AEUS).

To understand amount of meters that need to be changed, it is wise to analyze also their application by means of average

annual electric power consumption (see Table II) to evaluate efficiency of investments.

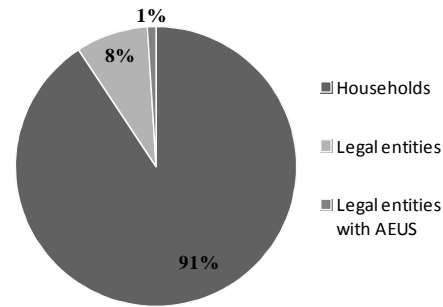

Fig. 2. Distribution of electric power meters by end-user type

According to AS "Sadales Tikls" data 42% (459 103) from all power meters are installed for clients with average annual consumption under 1000 kWh, where 283 700 power meters are installed for clients with average annual consumption up to 50 kWh, mainly consumers like garages, barns, basements, as well as holiday homes and apartments that are not occupied all the time. This means, that investments for smart meters are questionable, instead, a low cost monitoring system or device could be more suited, perhaps even with remote switch-off and switch-on capability.

TABLE II

ELECTRICAL POWER METERS DISTRIBUTION BY AVERAGE ANNUAL ENERGY CONSUMPTION

Type of electric power meter	% from total
up to 1000 kWh	42%
1000 - 2000 kWh	27%
2000 - 3000 kWh	13%
3000 - 4000 kWh	6%
4000 - 5000 kWh	3%
5000 - 6000 kWh	2%
more than 6000 kWh	7%

For the local household consumption monitoring system, for consumer it is not essential, to be connected with energy company metering device, but for future development it could be wise to make this interlinking available, either directly by DLMS or by another means – WiFi, WEB, PLC, etc [9].

#### B. Consumer Equipment Characteristics

It is possible to get average RMS current value, when looking at electrical device datasheet, but you cannot get full picture about maximum amplitude value, current waveform, reactive power and other, therefore an extensive measurements must be carried out.

To obtain the necessary data, three households for various sinusoidal and non-sinusoidal consumers at their maximum power were measured. As measuring equipment was used FLUKE 199C/S scope meter with Hall effect current clamp, as the measurements were made not in laboratory circumstances, they should be considered only as indicative.

Fig.3. shows sinusoidal consumer distribution by their consumption current (RMS value). Typically these consumers all are the equipment where main power consumer is heating element, like boiler, kettle, oven, iron, toaster and others.

Largest current value we need to measure is 25A for the induction cooktop in 1 phase connection, but we also need to remember that current sensor must measure instant current value that is even higher than RMS value. The voltage and current waveforms both are sinusoidal.

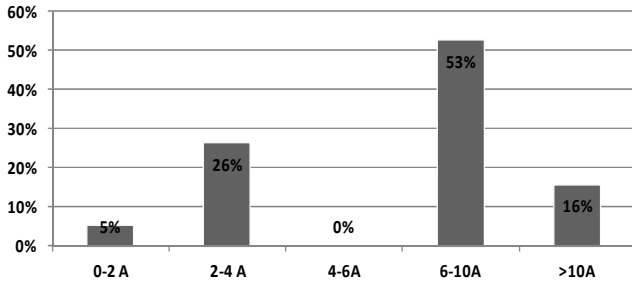

Fig. 3. Sinusoidal consumer distribution by RMS current value.

Fig.4. shows non-sinusoidal consumer distribution by their consumption current (RMS value). Fig.5. gives some examples of the waveforms, where the current is non-sinusoidal.

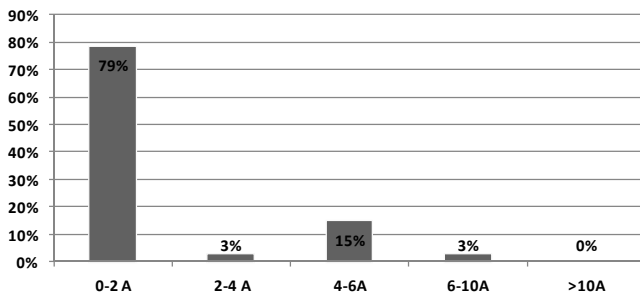

Fig. 4. Non-sinusoidal consumer distribution by TRMS current value.

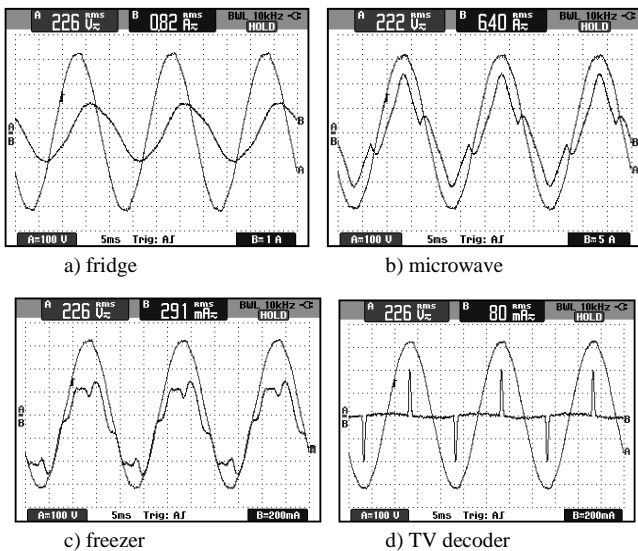

Fig. 5. Non-sinusoidal consumer waveform examples.

Thus it can be seen, that non-sinusoidal consumers are 79% in the range of 0-2A (RMS) and 15% in 4-6%, but anyway there are some 3% of consumers that lie in the range of 6-10A, these are the consumers like microwaves and vacuum cleaners.

### III. DEVELOPMENT OF THE MONITORING DEVICE

#### A. Method

The concept total monitoring system is supposed to work as shown in Fig.6 and described in details in [7]. There are two devices that are capable to send and receive the data, the main/central point measures both voltage and current, and also gathers the data from local monitoring devices (plugs, etc.), which measures only current value, and detects start of the voltage half-period. When data are gathered, according to algorithm, they are sent to PC/database, and then through software and internet connection, they can be uploaded to WEB and seen also on other computers of user.

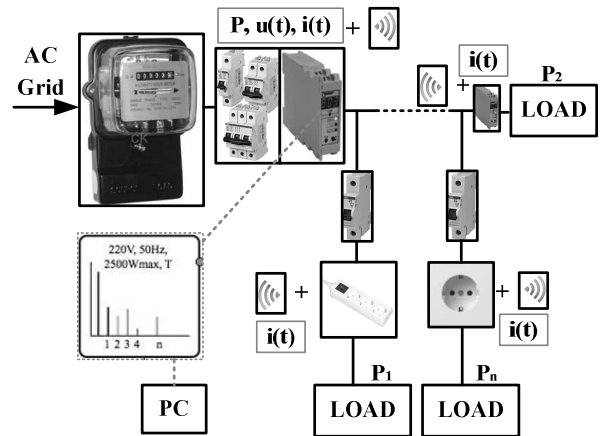

Fig. 6. Concept of monitoring system.

Fig.7. shows the method applied for measurement calculation. The basic idea is to measure instant values, as active load energy consumer is characterized by changes in the power curve and energy consumption is equal to area it covers.

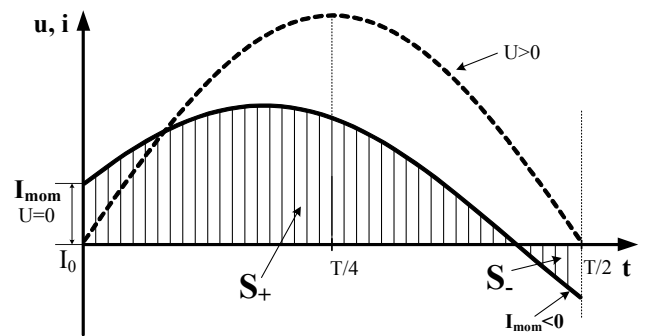

Fig. 7. The area ratio of the reactive nature of the consumer.

$$E \sim (S_+) - (S_-) \quad (1)$$

In the case of non-sinusoidal load, current may be higher or lower than 0 at the same time, the instantaneous voltage value is zero. Then the consumed active energy (E) is area difference between the area (S+) and the area (S-) and can be calculated by the following formula (1).

For current measurement a linear 5A and 20A range Hall sensor (ACS712) is selected, which with 0A current value, at the output will give 2.5+/-0.5V, and accordingly discrete value will be not equal to "0". Therefore current instant values are calculated as shown in (2), where  $I_H$  is the instant value from Hall sensor, but  $I_{const}$  is the value at zero load (see Fig.8.).

$$I_{mom} = I_H - I_{const} \quad (2)$$

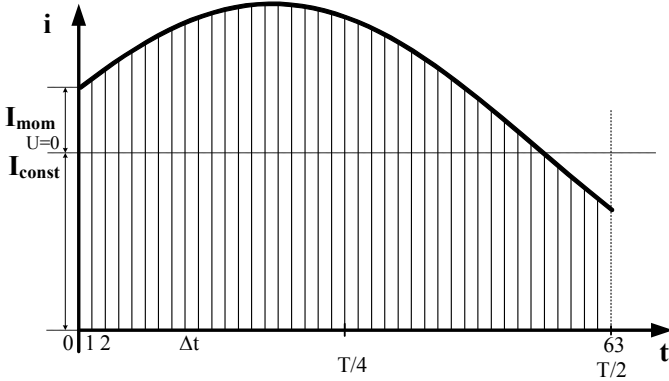

Fig. 8. Instant current calculation from measurements of Hall sensor.

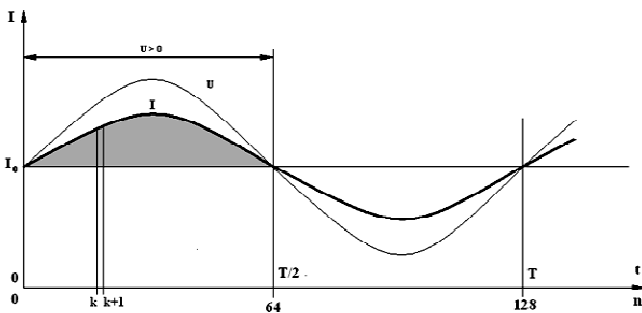

Fig. 9. Non-sinusoidal consumer waveform examples.

In order to calculate the areas, current values are summed in discrete time periods, where half of the period is divided in 64 measurements, where energy is characterized by formula (3)

$$E \sim \left( \sum_{k=0}^{63} (I_H - I_{const}) \right) \quad (3)$$

If instantaneous value  $I_H > I_{const}$ , then difference is above 0, and this characterizes sum of active and reactive energy. If  $I_H < I_{const}$ , then difference is negative and energy is transferred to grid.

$$E \sim \sum_{k=0}^{63} (I_H) - 64 \times I_{const} \quad (4)$$

$$I_{const} = \frac{\sum_{n=0}^{127} I_H}{128} \quad (5)$$

To calculate zero-point of Y axis ( $I_{const}$ ) see (5), instant values of Hall sensor must be summed for all the period (T), in this case  $2 \times 64 = 128$  measurements, and then the energy is described by (6). 128 measurements are enough, as the device is supposed not for very precise measurements, but for monitoring purposes.

$$E \sim \sum_{k=0}^{63} (I_H) - \frac{\sum_{n=0}^{127} I_H}{2} \quad (6)$$

### B. Hardware development

Communication module needs to send and receive small data packets with low speed (115.2 kbps) in half-duplex regime (cannot send and receive simultaneously). As the phase modulation is used in transceiver and communication is synchronized according to phase status, then the length of data packets depends on carrier-frequency phase changes for  $180^\circ$ . Hardware module is based on Atmel microcontroller ATxmega16A4U, and communication is using 868 MHz transceiver RFM22B-868, where functional block and control of communication module is shown in Fig.10. Effective length of antenna is 8.2 cm and in direct visibility module communicates up to 100m distance, consuming 20mA at supply voltage of 2.2V and 3.6V, in closed spaces the range decreases to 30 m. Fig.11. shows pictures of physical models of individual devices.

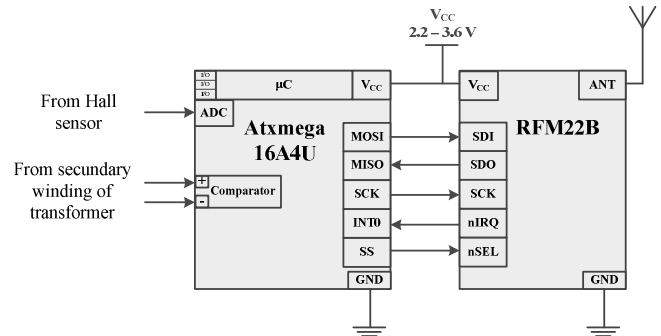

Fig. 10. Functional block and control of communication module.



Fig. 11. Physical models of developed hardware.

#### IV. CONCLUSIONS

Totally five such measurement devices have been built with two current detection ranges – 2 devices for 20A range and 3 devices for 5A range. To detect average deviation, an experiment was carried out, where all 5 devices simultaneously measured the same consumer. Average deviation was 2.13% to 3.74% when measured 40W incandescent lamp, 0.92% to 2.02% when 100W high pressure discharge lamp, 1.51% to 2.97% when LCD monitor, and 0.14% to 0.76% when sandwich-maker. Thus it can be seen, that average device precision is between 1-2% for 5A range and up to 4% at 20A range. The preliminary measurements were done using Fluke 199C oscilloscope and Amprobe 6 digit multimeter, as the next task is to carry more detailed measurements using more precise measurement devices. For monitoring purposes such precision is acceptable, and the next challenge is to decrease the costs of the elements.

#### ACKNOWLEDGEMENT

Authors acknowledge the work of experts from Latvian Energy Companies – AS “Sadales Tīkls” and AS “Latvenergo” for provided information.

Development of this article is co-financed by the RTU project “LATENERGI”.

#### REFERENCES

- [1] V. Giordano, F. Gangale, G. Fulli (JRC-IE), M. Sánchez Jiménez (DG ENER), *Smart Grid projects in Europe: lessons learned and current developments*, Publications Office of the European Union, 2011, Chapter 1.
- [2] Document of EU Commission Task Force for Smart Grids, Expert Group 1, *Functionalities of smart grids and smart meters, Final Deliverable*, December 2010, available: [http://ec.europa.eu/energy/gas\\_electricity/smartgrids/doc/expert\\_group1.pdf](http://ec.europa.eu/energy/gas_electricity/smartgrids/doc/expert_group1.pdf).
- [3] *The Smart Grid an Introduction*, document prepared for the U.S. Department of Energy by Litos Strategic Communication under contract No. DE-AC26-04NT41817, Subtask 560.01.04, available: [http://energy.gov/sites/prod/files/oeprod/DocumentsandMedia/DOE\\_SG\\_Book\\_Single\\_Pages%281%29.pdf](http://energy.gov/sites/prod/files/oeprod/DocumentsandMedia/DOE_SG_Book_Single_Pages%281%29.pdf).
- [4] G. Rouse, J. Kelly, *Electricity reliability: problems, progress and policy solutions*, Galvin Electricity Initiative, February 2011, available at: [http://www.galvinpower.org/sites/default/files/Electricity\\_Reliability\\_031611.pdf](http://www.galvinpower.org/sites/default/files/Electricity_Reliability_031611.pdf).
- [5] M. H.J. Bollen, J. Zhong, F. Zavoda, J. Meyer, A. McEachern, F. Córcoles López, *Power Quality aspects of Smart Grids*, International Conference on Renewable Energies and Power Quality (ICREPPQ'10) Granada (Spain), 23th to 25th March, 2010.
- [6] C. Marnay, B. Nordman, J. Lai, *Future Roles of Milli-, Micro-, and Nano- Grids*, CIGRÉ International Symposium The electric power system of the future, Integrating supergrids and microgrids, Bologna, Italy, 13-15 September 2011, available: <http://emp.lbl.gov/reports>.
- [7] Apse-Apsitis, P.; Avotins, A.; Ribickis, L., "Concept of low-cost energy monitoring system for household application," *ELMAR*, 2011 Proceedings, vol., no., pp.149,152, 14-16 Sept. 2011.
- [8] Apse-Apsitis, P., Avotins, A., Ribickis, L., Zakis, J., *Development of energy monitoring system for SmartGrid consumer application*, (2012) *IFIP Advances in Information and Communication Technology*, 372 AICT, pp. 347-354.
- [9] A. Zabasta, N. Kunicina, L. Ribickis. The Problem Issues of Intelligent Monitoring and Control of CIS in Latvia // *Electronics and Electrical Engineering*. – Kaunas: Technologija, 2012. – No. 2(118). – P. 57–62.
- [10] J. Stromback, C. Dromacque, M. H. Yassin, *The potential of smart meter enabled programs to increase energy and systems efficiency: a mass pilot comparison*, VaasaETT, Global Energy Think Tank available at <http://www.esmig.eu/press/filestor/empower-demand-report.pdf>



**Ansis Avotins** is 4<sup>th</sup> year PhD student at the faculty of Power and Electrical engineering study program „ Computer Control of Electrical Technology”. Master degree of Science in Electrical Engineering achieved in 2005. Main field of study is autonomous lighting systems. From 2004 working as a chief Laboratory Manager at RTU, IEEI. A member of IEEE and ACM associations.



**Peteris Apse-Apsitis** is a researcher of Riga Technical University Institute of Industrial Electronics and Electrical Engineering. Main fields of scientific interests are power electronics, robotics and mobile ICT applications. He is author of many industrial solutions and applications and patented inventions. A member of IEEE association.



**Maris Kunickis** is 2<sup>nd</sup> year PhD student of Riga Technical University Institute of Industrial Electronics and Electrical Engineering. Main fields of scientific interests are power electronics, electrical grid and power distribution.



**Leonids Ribickis** is a professor, Vice Rector for Science of Riga Technical University. Received Dipl.El.Ing. qualification in 1970 (Riga Polytechnic Institute), in 1980 received PhD. in Belorussian Polytechnical Institute and in 1994 – Dr.Habil.Sc.ing. at RTU. Main research fields: Electric Drives, Power Electronics, Intelligent Electronic Equipment. Full member of Latvian Academy of Science, IEEE Latvia section Chairman, Board Member of EPE.

