



RIGA TECHNICAL
UNIVERSITY

Fabian Andres Diaz Sanchez

**SUSTAINABILITY IN FOOD SUPPLY CHAINS:
A LIFE CYCLE PERSPECTIVE**

Doctoral Thesis

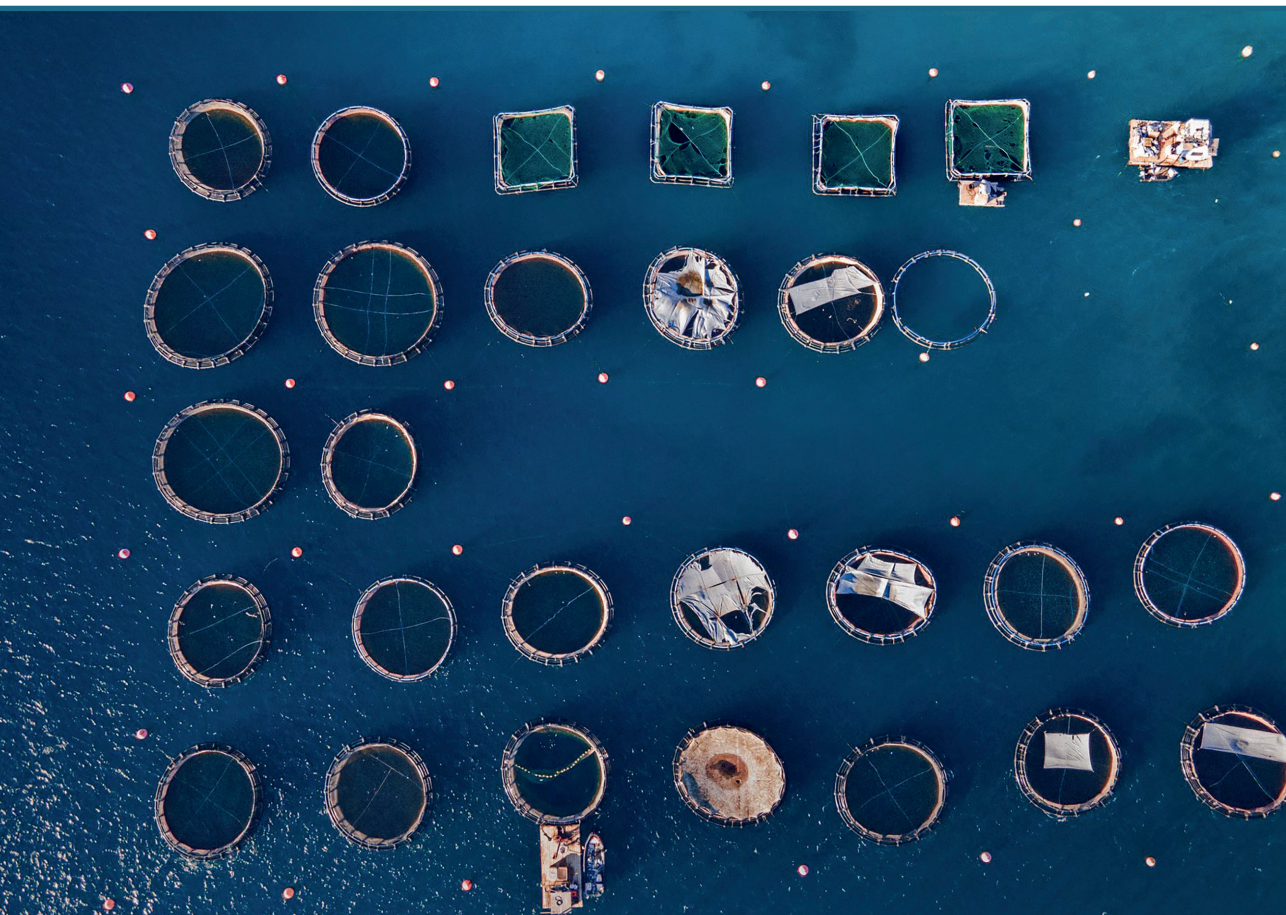

RTU Press
Riga 2025

RIGA TECHNICAL UNIVERSITY

Faculty of Natural Sciences and Technology
Institute of Energy Systems and Environment

Fabian Andres Diaz Sanchez

Doctoral Student of the Doctoral Study Programme “Environmental Engineering”

**SUSTAINABILITY IN FOOD SUPPLY CHAINS:
A LIFE CYCLE PERSPECTIVE**

Doctoral Thesis

Scientific supervisor

Professor Dr. sc. ing.

FRANCESCO ROMAGNOLI

RTU Press

Riga 2025

Diaz S., F. A. Sustainability in Food Supply Chains:
A Life Cycle Perspective. Doctoral Thesis. Riga: RTU
Press. 192 p.

Published in accordance with the decision of the
Promotion Council “RTU P-19” of 26. June 2024,
No. 207.

DOCTORAL THESIS PROPOSED TO RIGA TECHNICAL UNIVERSITY FOR THE PROMOTION TO THE SCIENTIFIC DEGREE OF DOCTOR OF SCIENCE

To be granted the scientific degree of Doctor of Science (Ph.D.), the present Doctoral Thesis has been submitted for defense at the open meeting of the RTU Promotion Council on 29th September 2024 at 15:00 at the Faculty of Natural Sciences and Technology of Riga Technical University, Āzenes iela 12/1.

OFFICIAL REVIEWERS

Professor Dr. sc. ing. Gatis Bažbauers
Riga Technical University

Professor Dr. sc. Andrea Capelli
Sapienza University of Rome, Italy

Professor Dr. sc. Giuseppe Tomasoni
University of Brescia, Italy

DECLARATION OF ACADEMIC INTEGRITY

I hereby declare that the Doctoral Thesis submitted for review to Riga Technical University for promotion to the scientific degree of Doctor of Science (Ph. D.) is my own. I confirm that this Doctoral Thesis has not been submitted to any other university for promotion to a scientific degree.

Fabian Andres Diaz Sanchez..... (signature)

Date:

The Doctoral Thesis has been written in English. It consists of an Introduction, 4 chapters, Conclusions, 45 figures, 11 tables, 7 appendices; the total number of pages is 112, not including appendices. The Bibliography contains 241 titles.

ANNOTATION

This dissertation evaluates sustainability within food supply chains (FSCs), addressing the critical need for comprehensive assessment tools. The food industry plays a significant role at the social level and, at the same time, an important part in global environmental degradation, deforestation, greenhouse gas emissions, and freshwater consumption. Food supply chains, particularly in meat and fish products, demand significant energy inputs, presenting multiple challenges for sustainability. Current methodologies for assessing sustainability in food supply chains often neglect the multidimensional nature of sustainability, primarily focusing on environmental aspects and overlooking economic and social dimensions.

This research integrates a Life Cycle Thinking approach to holistically assess food supply chains' environmental, economic, and social impacts. The study proposes a methodological framework combining Life Cycle Assessment, Life Cycle Costing, and Social LCA. Case studies from beef and fish cold supply chains evaluate baseline scenarios and energy efficiency measures, including anaerobic digestion and renewable energy integration. Results demonstrate the substantial environmental and economic benefits of these measures, particularly in reducing carbon footprints and improving energy use efficiency through the circular economy and industrial symbiosis principles.

The doctoral thesis highlights the need for flexible and context-specific LCA boundaries, enabling tailored energy efficiency interventions in food supply chains. A developed Life Cycle Sustainability Tool further supports supply chain managers and decision-makers by providing precise inventory data and visual outputs, integrating economic values like Net Present Value and Internal Rate of Return. This tool has been validated through practical case studies, proving its effectiveness in evaluating and improving sustainability in food cold supply chains. In conclusion, the dissertation provides a roadmap for policymakers and industry stakeholders to achieve sustainability transformations by bridging the gap between theoretical concepts and practical applications. The document consists of five main chapters.

Chapter 1 provides an introduction, outlines the research hypothesis, main objectives, as well as the topicality of sustainability evaluations in different sectors. An extensive literature review exploring food supply chains' environmental impacts and the current sustainability assessment methods. Chapter 2 provides an extensive literature review, exploring the environmental impacts of food supply chains and the current sustainability assessment methods. It discusses the limitations of existing tools and introduces the need for a holistic, lifecycle-based approach to address these gaps.

Chapter 3 outlines the methodology, including the development and integration of LCA, LCC, and S-LCA within the context of the food supply chain. This chapter details the selection parameters for case studies and main methodological choices within food cold supply chain cases. Chapter 4 presents the results and analysis of the case studies, focusing on the environmental and economic impacts of EEMs in beef, fish, and egg supply chains. The findings highlight the significant potential of circular economy strategies in reducing energy consumption and enhancing sustainability.

Chapter 5 introduces the life cycle sustainability tool (LCST) and explains its practical application for decision-makers. The chapter discusses how the tool integrates key performance indicators, visual outputs, and economic metrics to guide policy and industry-level decisions.

Chapter 6 concludes the dissertation by summarizing the key findings and offering recommendations for future research and policy implementations to enhance the sustainability of food supply chains.

ANOTĀCIJA

Šī disertācija novērtē ilgtspējību pārtikas piegādes ķēdēs (FSC), risinot nepieciešamību pēc visaptverošiem novērtēšanas rīkiem. Pārtikas rūpniecībai ir nozīmīga loma sociālajā līmenī un, vienlaikus, būtiska loma globālās vides degradācijā, mežu izciršanā, siltumnīcefekta gāzu emisijās un saldūdens patēriņā. Pārtikas piegādes ķēdes, īpaši gaļas un zivju produkti, pieprasa ievērojamu enerģijas patēriņu, radot daudzus ilgtspējības izaicinājumus. Pašreizējās metodes ilgtspējības novērtēšanai pārtikas piegādes ķēdēs bieži ignorē ilgtspējības daudzdimensiju raksturu, galvenokārt koncentrējoties uz vides aspektiem, neņemot vērā ekonomiskos un sociālos aspektus.

Šis pētījums integrē Dzīves Cikla Domāšanas pieeju, lai holistiski novērtētu pārtikas piegādes ķēžu vides, ekonomiskos un sociālos ietekmes aspektus. Pētījums piedāvā metodoloģisko ietvaru, kas apvieno Dzīves Cikla Novērtējumu (LCA), Dzīves Cikla Izmaksu aprēķinu (LCC) un Sociālo LCA. Izmantoti liellopu gaļas un zivju auksto piegādes ķēžu gadījumu pētījumi, lai novērtētu pamatscenārijus un energoefektivitātes pasākumus, tostarp anaerobo gremošanu un atjaunojamās enerģijas integrāciju. Rezultāti liecina par būtiskām vides un ekonomiskajām priekšrocībām šajos pasākumos, īpaši oglekļa pēdu samazināšanā un enerģijas izmantošanas efektivitātes uzlabošanā, izmantojot aprites ekonomikas un industriālās simbiozes principus.

Doktora disertācija uzsver nepieciešamību pēc elastīgām un kontekstuāli specifiskām LCA robežām, kas ļauj pielāgot energoefektivitātes pasākumus pārtikas piegādes ķēdēs. Izstrādātais Dzīves Cikla Ilgtspējības rīks (LCST) papildus atbalsta piegādes ķēžu vadītājus un lēmumu pieņēmējus, nodrošinot precīzus inventarizācijas datus un vizuālos izvadus, kā arī integrējot ekonomiskos rādītājus, piemēram, tīro pašreizējo vērtību (NPV) un iekšējo atdeves likmi (IRR). Šis rīks ir validēts, izmantojot praktiskus gadījumu pētījumus, pierādot tā efektivitāti ilgtspējības novērtēšanā un uzlabošanā auksto pārtikas piegādes ķēdēs. Noslēgumā disertācija sniedz ceļvedi politikas veidotājiem un nozares dalībniekiem, lai sasniegtu ilgtspējības transformācijas, pārvarot plaisu starp teorētiskajiem konceptiem un praktisko pielietojumu.

Dokuments sastāv no piecām galvenajām nodaļām.

1. nodaļa sniedz ievadu, izklāsta pētījuma hipotēzi, galvenos mērķus, kā arī ilgtspējības novērtēšanas aktualitāti dažādās nozarēs.

2. nodaļa piedāvā plašu literatūras pārskatu, pētot pārtikas piegādes ķēžu vides ietekmi un pašreizējās ilgtspējības novērtēšanas metodes. Tā apspriež esošo rīku ierobežojumus un izvirza nepieciešamību pēc holistiskas, dzīves cikla pieejas, lai risinātu šos trūkumus.

3. nodaļa izklāsta metodoloģiju, tostarp LCA, LCC un S-LCA izstrādi un integrāciju pārtikas piegādes ķēžu kontekstā. Šī nodaļa detalizē atlasē parametrus gadījumu pētījumiem un galvenās metodoloģiskās izvēles pārtikas auksto piegādes ķēžu gadījumos.

4. nodaļa prezentē gadījumu pētījumu rezultātus un analīzi, koncentrējoties uz energoefektivitātes pasākumu (EEM) vides un ekonomisko ietekmi liellopu gaļas, zivju un olu piegādes ķēdēs. Atklājumi uzsver aprites ekonomikas stratēģiju ievērojamo potenciālu enerģijas patēriņa samazināšanā un ilgtspējības veicināšanā.

5. nodaļa ievieš Dzīves Cikla Ilgtspējības rīku (LCST) un izskaidro tā praktisko pielietojumu lēmumu pieņēmējiem. Nodaļa apspriež, kā rīks integrē galvenos veikspējas

rādītājus, vizuālos izvadus un ekonomiskos rādītājus, lai vadītu politikas un nozares lēmumu pieņemšanu.

6. nodaļa noslēdz disertāciju, apkopojot galvenos rezultātus un piedāvājot ieteikumus turpmākajiem pētījumiem un politikas ieviešanai, lai uzlabotu pārtikas piegādes ķēžu ilgtspējību.

ACKNOWLEDGMENTS

I extend my heartfelt gratitude to all my colleagues who contributed to the creation of this thesis in some way. Your collective support and fruitful conversations have been the bedrock of this endeavor, making this work possible and meaningful.

Foremost, I am profoundly thankful to my supervisor, Professor Francesco Romagnoli, for their unwavering guidance, insightful solutions to scientific and non-scientific challenges, and for believing in my potential. His faith instilled in me the confidence to navigate and overcome the numerous obstacles encountered during my research journey.

My sincere appreciation also goes to Dagnia Blumberga, to whom I owe the opportunity to embark on this journey, something I had not even dreamed of seven years ago when I first came to Riga Technical University. To Julija Gusca, whose motivation and belief in my capacities and the direction of my research significantly contributed to the advancement of the field of environmental sciences. I am equally grateful to my colleagues, Maksims Feofilovs and Riccardo Paoli, whose advice, support, and friendship were instrumental in my conviction that life cycle assessment is a cornerstone in sustainability evaluations.

Finally, a special mention to my wife, Ieva Baldina, who provided me with the necessary motivation during the final phase of this work, offering loving words and support to help me endure the heavy task of completing this enterprise.

I would like to express my profound appreciation to each of you who has been part of this journey. Your collective efforts have enriched this thesis and my personal and professional growth.

NOMENCLATURE

FSC	Food Supply Chain
EPD	Environmental Product Declaration
CSRD	Corporate Sustainability Reporting Directive
LCA	Life Cycle Assessment
LCT	Life Cycle Thinking
LCC	Life Cycle Costing
S-LCA	Social Life Cycle Assessment
PRISMA	Preferred Reporting Items for Systematic Reviews and Meta-Analyses
ICCEE	Improving Cold Chain Energy Efficiency
EU	European Union
FAO	Food and Agriculture Organization of the United Nations
SDGs	Sustainable Development Goals
SCM	Supply Chain Management
KPI	Key Performance Indicator
LCI	Life Cycle Inventory
LCIA	Life Cycle Impact Assessment
TfS	Together for Sustainability
ESG	Environmental, Social, and Governance
CSR	Corporate Social Responsibility
GHG	Green House Gases
CDP	Carbon Disclosure Project
SME	Small and Medium Enterprises
CFC	Chlorofluorocarbons
ODP	Ozone Depletion Potential
HCFC	Hydrochlorofluorocarbons
GWP	Global Warming Potential
LCST	Life Cycle Sustainability Tool
LCSA	Life Cycle Sustainability Assessment
C-LCC	Conventional Life Cycle Costing
E-LCC	Environmental Life Cycle Costing
S-LCC	Societal Life Cycle Costing
EoL	End-of-Life
ABC	Activity-Based Costing
FW	Food Waste
EEM	Energy Efficiency Measures
FU	Functional Unit
PCR	Product Category Rules
AD	Anaerobic Digestion
CHP	Combined Heat and Power
DOC	Degradable Organic Content
SETAC	Society of Environmental Toxicology and Chemistry

CED	Cumulated Energy Demand
SNPV	Social Net Present Value
SCBA	Social Cost-Benefit Analysis

CONTENTS

Acknowledgments	8
Nomenclature	9
1. INTRODUCTION.....	13
1.1. Research hypothesis.....	14
1.2. Objectives and tasks	15
1.3. Scientific novelty	15
1.4. Practical significance	16
1.5. Scope and limitations.....	17
1.6. Research framework	18
1.7. Approbation of the research results	20
1.8. Other scientific publications	20
1.9. Participation in conferences.....	21
1.10. Supervised and co-supervised master thesis	21
2. LITERATURE REVIEW AND RESEARCH NEED	22
2.1. Sustainability concept.....	22
2.2. Sustainability in food supply chains	24
2.3. Overview of sustainability methods in food supply chains	26
2.3.1. Content analysis.	30
2.3.2. Industry-level sustainability evaluation methods	33
2.4. Food supply chain considerations.....	36
2.4.1. Additional sustainability considerations	38
2.5. Research gaps	39
3. METHODOLOGY.....	41
3.1. Research methods	42
3.1.1. PRISMA protocol.....	42
3.1.2. Environmental LCA	43
3.1.3. Life cycle costing	44
3.1.4. Social LCA and its challenges	47
3.1.5. Life cycle sustainability assessment.....	49
4. RESULTS AND DISCUSSION	54
4.1. Case studies description and main results	54
4.1.1. Beef supply chain	54
4.1.2. Fish supply chain.....	58
4.1.3. Eggs supply chain.....	63
4.1.4. Sustainability evaluation of food waste valorization	68
4.2. Summary of different scenarios.....	73
5. LIFE CYCLE SUSTAINABILITY TOOL.....	75
5.1. LCA output indicators	78
5.2. LCC output indicators.....	79
5.3. S-LCA (S-LCC) output indicators.....	80
5.4. Data collection procedure	80
5.5. Data input.....	84
5.6. LCA data processing and results visualization	85
5.7. LCC modeling	88

5.8. Tool validation.....	91
6. CONCLUSIONS AND RECOMMENDATIONS.....	92
6.1. Conclusions related to the objectives	93
6.2. Recommendations.....	94
6.3. Recommendations for Future Research.....	96
BIBLIOGRAPHY	97
Publications arising from this thesis.....	113

1. INTRODUCTION

Sustainability has emerged as a pivotal theme in the discourse of environmental conservation and economic development in the contemporary era of rapid globalization and technological advancement. This notion, deeply rooted in the understanding that we inhabit a finite planet with limited resources, has evolved significantly in recent decades. The Brundtland report defined sustainable development as *“the ability to meet present human needs without compromising the ability of future generations to meet their own”*. However, the journey from this foundational understanding to its application in specific sectors, such as food supply chains, is complex and filled with nuanced challenges.

The food industry, a critical player in the global economy, exemplifies the intricate interplay between economic growth, environmental stewardship, and social equity. The challenges in this sector range from carbon emissions and resource utilization to food safety and waste management, all of which are exacerbated by the globalization-driven elongation of food supply chains (FSCs). As international organizations and technological innovations strive to mitigate these impacts, a coherent, quantitative approach to sustainability assessment in the FSC becomes imperative.

Despite the acknowledgment of sustainability's importance in various industries, methodologies for its assessment often need more contextual depth and overlook key sustainability attributes. While crucial, the prevalent focus on financial dimensions overshadows the even more significant environmental and social aspects. Tools like Environmental Product Declarations (EPDs) and frameworks like the Corporate Sustainability Reporting Directive (CSRD) are attempts to close these gaps. Yet, they often need to improve in delivering a holistic picture of a product's or a company's sustainability.

Despite the progress made, assessing sustainability within FSCs presents unique challenges. Traditional methods often require capturing the full scope of environmental, economic, and social impacts. For instance, while raising consumer awareness, initiatives such as carbon labeling and food miles offer a limited perspective, focusing primarily on the environmental footprint and overlooking other crucial sustainability dimensions. Similarly, efforts to reduce food losses and waste, though beneficial, still need to fully address the broader implications for social equity and economic development.

Research trends in FSC sustainability have predominantly employed qualitative approaches, with case studies being a standard methodological tool. These studies provide valuable insights into various sustainability issues, including supplier management and sustainable development strategies. However, they often need a consistent theoretical framework, reflecting the growing state of this research field. Moreover, there is a pressing need for more in-depth investigations, particularly in developing countries, where inefficiencies in infrastructure and logistics can exacerbate food waste (FW) and undermine sustainability efforts.

In response to these challenges, there has been an emerging consensus on the need for holistic, multidimensional approaches to sustainability assessment in FSCs. These approaches advocate for integrating both “hard” quantitative methods like life cycle assessment (LCA) and “soft” qualitative methods to ensure a comprehensive understanding of sustainability impacts.

This blend of methodologies is crucial for addressing often-overlooked aspects such as human health and the interconnectedness of dietary choices and environmental outcomes.

This Thesis posits that while well-intentioned, the current approach to sustainability assessment in the food supply chain needs to be more cohesive and comprehensive. It contends that there is a conspicuous absence of a standardized, quantifiable methodology that integrates the multifaceted nature of sustainability, encompassing both environmental, economic, and social dimensions. This research aims to architect a holistic, adaptable model for the food supply chain spectrum by dissecting current methodologies and highlighting the disparities in sustainability evaluation. This endeavor is academically significant and crucial for policymakers and industry leaders in bridging the gap between theoretical sustainability concepts and actionable, impactful measures.

In summary, the urgency of this research is underscored by the escalating demands on the food industry to align with sustainable practices amid global environmental challenges. It advances the premise that a comprehensive, quantitatively driven methodology is essential for a genuine sustainability transformation in food supply chains.

1.1. Research hypothesis

This Doctoral Thesis hypothesizes that operationalizing life cycle thinking (LCT) through an integrated framework, encompassing environmental LCA, life cycle costing (LCC), and social life cycle assessment (S-LCA) dimensions, enables a quantitative, standardized, and sector-specific evaluation of sustainability in food supply chains (FSCs). By addressing current methodological gaps, the proposed approach moves beyond fragmented assessments and provides a universally applicable, yet adaptable methodology tailored to the unique operational and contextual features of the food industry.

Specifically, the Thesis tests the following hypotheses:

- Hypothesis 1 (H1): An integrated LCT framework can systematically identify sustainability hotspots and intervention opportunities across different stages of FSCs, enabling the implementation of targeted measures such as energy efficiency improvements and side-stream valorization that can potentially reduce environmental impacts while maintaining economic viability.
- Hypothesis 2 (H2): The life cycle sustainability tool (LCST), developed within this research, provides a scalable, transparent, and decision-oriented mechanism to operationalize the LCT framework. By generating standardized environmental, economic, and social performance indicators, complemented with economic outputs (e.g., net present value, internal rate of return), the tool supports evidence-based decision-making across both large corporations and SMEs.
- Hypothesis 3(H3): The application of the LCST in real-world case studies (beef, fish, and egg cold chains) validates its practical feasibility and effectiveness, demonstrating its capacity to produce consistent and actionable sustainability insights that contribute to circularity, efficiency, and alignment with EU and global sustainability goals.

In summary, the Thesis postulates that operationalizing life cycle thinking through a customized tool can enable consistent, actionable sustainability assessments in the food industry, contributing to a more circular, efficient, and environmentally responsible supply chain system.

1.2. Objectives and tasks

The main aim of this study is to develop and validate a comprehensive life cycle thinking-based methodology for the standardized, quantitative sustainability evaluation of food supply chains. To achieve this aim, the study pursues the following objectives and tasks:

- Investigate current sustainability assessment methods in the food sector, paying particular emphasis to food supply chains to identify methodological and practical gaps, barriers to usability, and opportunities for integrating environmental, social, and economic pillars
- Tailor and design an LCT-based framework to address sustainability's environmental, social, and economic dimensions, specifically contextualized for food supply chains.
- Apply the LCT methodology to selected case studies within the food industry (e.g., beef, fish, fruits, waste, eggs) to test assessing its ability to capture sustainability trade-offs across diverse supply chain configurations.
- Interpretation of LCT-based methodology to identify key sustainability hotspots in the food supply chain that help analyze and reduce environmental impacts, minimize food loss, and enhance food quality at consumer endpoints, thus improving the overall sustainability of the supply chain.
- Develop and validate an LCT decision-support tool designed to be user-friendly and industry-oriented, providing insights into the environmental footprint and economic and social performance, enabling knowledge transfer from academia to industry, and supporting decision-makers in implementing sustainability strategies in real-world supply chains.

1.3. Scientific novelty

This Doctoral Thesis advances sustainable supply chain management by moving beyond the established conceptual importance of sustainability and life cycle thinking, focusing instead on operationalizing these principles into a practical, quantifiable, and industry-specific framework for the food sector. The research introduces a life cycle sustainability (LCS) framework that integrates environmental (LCA), economic (LCC), and social (S-LCA) dimensions into a single multidisciplinary method, validated through real-world case studies.

The scientific novelty of this study lies in its ability to bridge the gap between theoretical sustainability models and their practical implementation. Despite the existing fragmented or overly simplistic approaches, the proposed framework delivers a universally applicable yet user-friendly tool that enables both large corporations and small and medium-sized enterprises

(SMEs) to consistently evaluate and improve their sustainability performance, with an emphasis on food supply chains.

By providing key insights for supply chain actors and policymakers, the framework supports applications at both regional and global levels. Thus, the scientific contribution of this research is the creation of a quantifiable, transferable, and comprehensive sustainability framework for food supply chains. This approach not only advances global environmental and social goals but also transforms established concepts into an actionable decision-support tool capable of driving measurable changes in industry practice.

1.4. Practical significance

This Thesis contributes novelty by transforming established life cycle thinking principles into a practical, user-friendly framework that enables consistent sustainability assessment in food supply chains.

More specifically, this Thesis delivers tangible practical value by bridging the gap between academic research and real-world application in sustainable food supply chain management. The developed LCST, grounded in a comprehensive LCT framework, has been validated through empirical case studies in beef, fish, and egg cold chains. These applications developed within the Thesis demonstrate the tool's ability to identify high-impact stages of the supply chain, quantify environmental burdens, and evaluate the cost-effectiveness of energy efficiency measures such as anaerobic digestion and renewable energy integration.

In practical terms, the proposed LCST enables supply chain managers and decision-makers to model different scenarios, compare environmental and economic trade-offs, and prioritize interventions based on quantifiable sustainability performance. For instance, in the Latvian fish cold chain case, the tool facilitated the identification of energy efficiency measures with the potential to deliver lower environmental impacts and improved the internal rate of return

Moreover, the tool's design enables adaptation across diverse food sectors and geographies, making it relevant for policy actors, particularly in light of emerging EU sustainability directives and Corporate Sustainability Reporting requirements. Its transparent output indicators and user-friendly interface make it accessible to SME, addressing a common limitation in existing LCA software.

Beyond industry applications, the methodological framework and case findings provide a rich resource for educational programs in environmental engineering, sustainability analytics, and supply chain management. The tool has already been incorporated into master's theses projects at Riga Technical University, supporting student-led sustainability evaluations in real-life industrial contexts.

Overall, the Thesis contributes a validated, scalable, and adaptable solution to the complex challenge of integrating sustainability into food supply chains—with demonstrable impacts at the operational, strategic, and educational levels.

1.5. Scope and limitations

This Thesis focuses on developing a quantitative framework for assessing sustainability in FSCs using life cycle thinking tools. The scope of this research encompasses:

- Analysis of existing sustainability assessment models: A comprehensive review and critique of current models and methodologies in assessing FSC sustainability.
- Development of a quantitative framework: Crafting a novel framework that integrates environmental, economic, and social dimensions of sustainability in a quantifiable manner, specifically tailored to the unique characteristics of FSCs.
- Case studies in specific FSC sectors: Applying the developed framework to selected case studies within the FSC, covering stages such as agriculture, processing, distribution, and retail, to illustrate its applicability and effectiveness.
- Consideration of diverse geographical contexts: While the research will aim to be globally relevant, particular attention will be given to European supply chains, considering data availability and the significance of the food supply chain in those areas.

While this study aims to contribute significantly to the field of sustainability in FSCs, certain limitations are inherent in its scope and methodology.

- Data availability and reliability: The accuracy and comprehensiveness of the sustainability assessment are contingent upon the availability and reliability of data across different stages of the FSC.
- Methodological constraints: The complexity of integrating various sustainability dimensions into a single quantitative framework may pose challenges, particularly in balancing depth and breadth of analysis.
- Generalizability: While the framework developed in this research aims to be adaptable across various sectors of the FSC, its applicability may vary depending on specific industry characteristics and geographical contexts.
- Temporal scope: The research will focus on current and recent data; thus, long-term sustainability trends and future projections may not be fully captured.
- Interdisciplinary challenges: Given the interdisciplinary nature of sustainability assessment, spanning environmental science, economics, and social sciences, synthesizing these diverse perspectives into a cohesive framework presents inherent challenges.

The defined scope and acknowledged limitations of this research serve to clarify the boundaries and expectations of the study. They provide a framework for the research, ensuring a focused and realistic approach to understanding and improving sustainability in food supply chains.

1.6. Research framework

This Doctoral Thesis employs a structured research framework that transforms the conceptual foundations of life cycle thinking (LCT) into a practical, operational methodology tailored to the food industry. The framework follows a logical sequence: starting with an evaluation of existing sustainability assessment practices, moving through the development and application of a new methodology, and concluding with both theoretical advancements and practical contributions. Part of the framework was developed during the author's participation in the *Improving Cold Chain Energy Efficiency (ICCEE)* project, funded by the European Union's Horizon 2020 research and innovation programme under grant agreement No. 847040. This collaboration enriched the methodological design and strengthened the empirical dimension of the study through direct industry engagement.

The Thesis is structured into five research steps, which sequentially cover the literature review, methodology development, case study applications, results and discussion, and final conclusions with recommendations. Each chapter builds on the previous one, ensuring a coherent progression from the identification of research gaps to the validation and refinement of the proposed methodology. This structure guarantees both theoretical depth and practical relevance, culminating in a comprehensive understanding of the implications for sustainable food supply chain management.

Error! Reference source not found. provides an overview of the research framework, highlighting the connections between research objectives and the top-down methodological approach [1]. This visual representation underscores the systematic and rigorous nature of the study, as well as its focus on addressing critical challenges in sustainability evaluation.

The methodological choices were informed by a comprehensive literature review that identified state-of-the-art approaches for quantitative sustainability assessment. These include life cycle assessment (LCA), life cycle costing (LCC), and social life cycle assessment (S-LCA), complemented by recognised impact assessment models and international standards (e.g., ISO 14040/44 and UNEP guidelines). A concise description of these methods is provided in Chapter 3, while their integration and application are demonstrated in the empirical chapters. For a more detailed discussion of their theoretical underpinnings and practical implications, reference should be made to the full text of the Thesis.

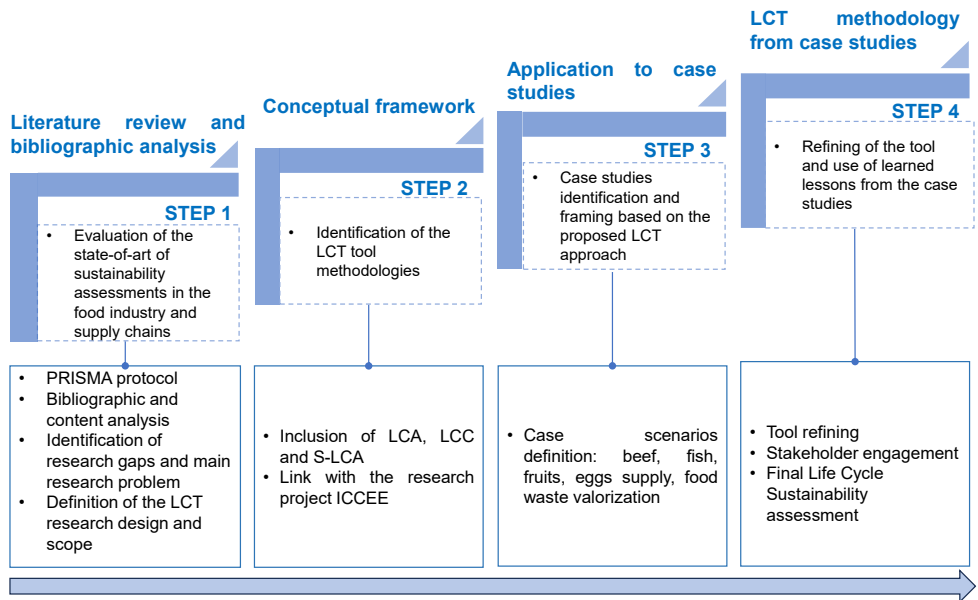

Fig. 1.1. Research framework of the Doctoral Thesis.

The framework consists of four sequential steps:

- Step 1: Literature review and bibliographic analysis

The research begins with a systematic analysis of existing practices for sustainability assessment in food supply chains, with particular focus on LCT-based methodologies (LCA, LCC, S-LCA). This step identifies methodological gaps and limitations in current approaches, establishing the research problem and defining the scope for methodological development.

- Step 2: Conceptual framework development

Building on the insights of Step 1, a standardized, quantitative, and multi-dimensional LCT methodology is developed. This framework explicitly integrates environmental, economic, and social dimensions, while adapting to the operational and contextual characteristics of food supply chains. The outcome is a sector-specific conceptual model that operationalizes LCT into an actionable decision-support structure.

- Step 3: Application to case studies

The proposed methodology is tested through empirical application to selected case studies (beef, fish, and egg cold chains). These represent critical segments of the food industry, chosen for their energy-intensive processes and sustainability challenges. The case studies serve as testing grounds to validate the framework's applicability, identify sustainability hotspots, evaluate trade-offs, and propose targeted interventions to reduce environmental burdens and improve efficiency.

- Step 4: Refinement of the LCT methodology

Insights gained from the case studies are used to refine and strengthen the proposed methodology. The iterative process enhances robustness, usability, and adaptability, resulting in the development of the life cycle sustainability tool (LCST). This refinement ensures

methodological consistency, standardized indicators, and practical relevance for both policymakers and industry practitioners, including SMEs.

Reflecting this framework, the Thesis is structured into chapters covering the literature review, methodology development, case study application, results and discussion, and conclusions with recommendations. Each chapter builds on the previous, demonstrating the interplay between theoretical reasoning and empirical validation.

1.7. Approbation of the research results

1. **Diaz, F.** et al. Effects of Energy Efficiency Measures in the Beef Cold Chain: A Life Cycle-based Study. *Environmental and Climate Technologies* 25, 343–355 (2021).
2. **Diaz Sanchez, F. A.**, Koiro, L. & Romagnoli, F. Energy Efficiency Measures on Cold Supply Chains Problem identification and gaps for the fish sector. Conference Proceedings of the IEEE 62nd International Scientific Conference on Power and Electrical Engineering of Riga Technical University (RTUCON) 1–6 (IEEE, 2021). doi:10.1109/RTUCON53541.2021.9711739.
3. **Diaz, F.**, Koiro, L. & Romagnoli, F. Environmental and economic life cycle evaluation of potential energy efficiency measures on Latvian fish supply chain. *Future Foods* 6, 100203 (2022).
4. **Diaz, F.** et al. The ICCEE Toolbox. A Holistic Instrument Supporting Energy Efficiency of Cold Food and Beverage Supply Chains. *Environmental and Climate Technologies* 26, 428–440 (2022).
5. Ruiz, M. & **Diaz, F.** Life Cycle Sustainability Evaluation of Potential Bioenergy Development for Landfills in Colombia. *Environmental and Climate Technologies* 26, 454–469 (2022).
6. **Diaz, F.**, Pakere, I. & Romagnoli, F. Life Cycle Assessment of Low Temperature District Heating System in Gulbene Region. *Environmental and Climate Technologies* 24, 285–299 (2020).

Other scientific publications related to the topic, but not included in the Thesis:

- Zlaugotne, B., **Diaz Sanchez, F. A.**, Pubule, J. & Blumberga, D. Life Cycle Impact Assessment of Microalgae and Synthetic Astaxanthin Pigments. *Environmental and Climate Technologies* 27, 233–242 (2023).
- Zlaugotne, B., **Sanchez, F. A. D.**, Pubule, J. & Blumberga, D. Protein Alternatives for Use in Fish Feed – Life Cycle Assessment of Black Soldier Fly, Yellow Mealworm and Soybean Protein. *Environmental and Climate Technologies* 27, 581–592 (2023).

1.8. Other scientific publications

- **Diaz, F.** & Cilinskis, E. Use of Multi-Criteria TOPSIS Analysis to Define a Decarbonization Path in Colombia. *Environmental and Climate Technologies* 23, 110–128 (2019).

- Vamza, I., **Diaz, F.**, Resnais, P., Radziņa, A. & Blumberga, D. Life Cycle Assessment of Reprocessed Cross Laminated Timber in Latvia. *Environmental and Climate Technologies* 25, 58–70 (2021).
- Bumbiere, K., **Diaz Sanchez, F. A.**, Pubule, J. & Blumberga, D. Development and Assessment of Carbon Farming Solutions. *Environmental and Climate Technologies* 26, 898–916 (2022).

1.9. Participation in conferences

- **Diaz, F.** & Cilinskis, E. Use of Multi-Criteria TOPSIS Analysis to Define a Decarbonization Path in Colombia. *The Conference of Environmental and Climate Technologies CONECT 2019. Riga*
- **Diaz Sanchez, F. A.**, Koiro, L. & Romagnoli, F. Energy Efficiency Measures on Cold Supply Chains Problem identification and gaps for the fish sector. *IEEE 62nd International Scientific Conference on Power and Electrical Engineering of Riga Technical University (RTUCON), 2021. Riga*
- Ruiz, M. & **Diaz, F.** Life Cycle Sustainability Evaluation of Potential Bioenergy Development for Landfills in Colombia. *The Conference of Environmental and Climate Technologies CONECT 2022. Riga*
- **Diaz, F.** et al. The ICCEE Toolbox. A Holistic Instrument Supporting Energy Efficiency of Cold Food and Beverage Supply Chains. *The final ICCEE conference, towards more energy efficient companies – focus on various industry sectors. Riga.*

1.10. Supervised and co-supervised master thesis

- Arnis Dzalbs. Analysis and modelling of the cold supply chain of frozen berries: a life cycle-based approach for a Latvian case study. RTU, 2020
- Lolita Koiro. Energy efficiency measures on cold supply chains- quantitative approach based on life cycle thinking perspective. RTU, 2021.
- M Matuko. Life cycle assessment of cold supply chains: a case study of a Latvian egg producer. RTU, 2022

2. LITERATURE REVIEW AND RESEARCH NEED

2.1. Sustainability concept

Over the past five decades, there has been a growing recognition that we inhabit a finite planet with finite resources. The recognition of this fundamental principle serves as the foundation for the notion of sustainability, which was initially articulated as “the capacity to fulfill current human needs while safeguarding the interests of future generations” in the 1987 Brundtland Report [2]. This description aligns with sustainable development, as it encompasses the essential requirements that society must satisfy.

Sustainability and sustainable development vary in that sustainability is the ultimate objective, representing the state of a society that has achieved sustainability via a series of actions. On the other hand, sustainable development refers to the ongoing process of achieving sustainability. However, when examining the description outlined in the Brundtland Report about sustainable development, it is evident that while it introduced the ethical principle of achieving fairness between generations, it did not clarify the specific "needs" that must be fulfilled. Could those needs be regarded as desires? Does that term suggest that economic expansion is an inherent component of development? This ambiguity raises a significant apprehension as the existing financial framework depends on expansion in materials and energy usage, adversely impacting the natural environment for decades. The previous definition does not directly address the natural environment; it solely concentrates on human needs or preferences. The report explicitly states that the "needs" encompass safeguarding and preserving the natural environment, but the commonly accepted definition does not.

The question of whether the word “need” should be replaced with “well-being”, “utility”, or “welfare” has been debated. This viewpoint results in a limited perspective that focuses solely on human needs, disregarding the consideration of other species unless they serve a specific function in fulfilling those needs. By 2000, a more precise elucidation of sustainable development appeared: “Sustainable development encompasses forms of economic and social progress that safeguard and improve the natural environment and promote social fairness.”[3]. This expanded concept incorporates three dimensions: ecological, economic, and social. Furthermore, it emphasizes that environmental elements and social equality are fundamental principles for achieving sustainable growth, and no compromises should be made.

Evidently, “development” is not always directly associated with economic growth. The ecological economy field also addresses this element, defining development as enhancing human well-being or realizing human potential [4]. The ecological economy perspective emphasizes the integration of environmental preservation into development processes, aiming for economic growth and social development alongside sustainable use of natural resources. This approach requires that environmental valuation, monetary incentives, and policy frameworks be aligned to ensure ecological sustainability, recognizing the economic valuation of the environment as just one dimension among ecological, sociocultural, and other values. It highlights the critical role of environmental assessment in informing valuation and decision-making processes to prevent irreversible ecological losses and promote sustainability [5].

The main benefit delivered by the ecological and economic fields to understanding sustainability is recognizing a carrying capacity defined by thresholds of ecosystem resilience. Such recognition has shifted the overlook of the environment as a provider of renewable and non-renewable materials to the environment as a supplier of ecosystem services (i.e., the ability to absorb waste, create clean water, air, etc.). This new look at the issue of operating an economic subsystem within the natural limits has led to the recognition of the ecological planetary boundaries [6] and the emergence of the doughnut economics concept [7], which integrates social issues.

As explained by the author of the doughnut representation, “*The Doughnut combines two concentric radar charts to depict the two boundaries—social and ecological—that encompass human wellbeing. The inner boundary is a social foundation; below lies shortfalls in well-being, such as hunger, ill health, illiteracy, and energy poverty.*” The figure, as revisited in 2017 in the paper "A Doughnut for the Anthropocene: humanity's compass in the 21st century", is presented in **Error! Reference source not found.**

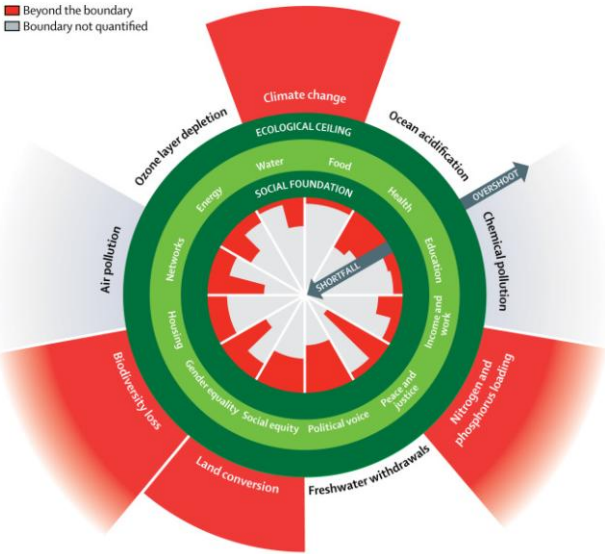

Fig. 2.1. Social shortfalls and environmental overshoot representation [7].

However, planetary boundaries, the safe operating space for humanity to live without transgressing Earth's systems and subsystems, were defined in 2009 [6]. Planetary boundaries are directly connected to understanding environmental sustainability, which can be defined as a critical value for a determined concentration of a control variable [6]. Since then, the concept of planetary boundaries has become a cornerstone in context-based environmental sustainability, and research on understanding the current state of earth systems has experienced significant interest in the last decade [8], [9], [10].

In the most recent research from the Stockholm Resilience Centre, for the first time, a study provided a detailed summary of planetary resilience by plotting out all nine boundary processes that define a safe operating space for humanity [9]. The main finding was that six of the nine boundaries are transgressed, with ocean acidification approaching its planetary limit, underscoring the urgency for global environmental action. This alarming development emphasizes the increasing strain on Earth's systems due to human activities (see Fig. 2.2).

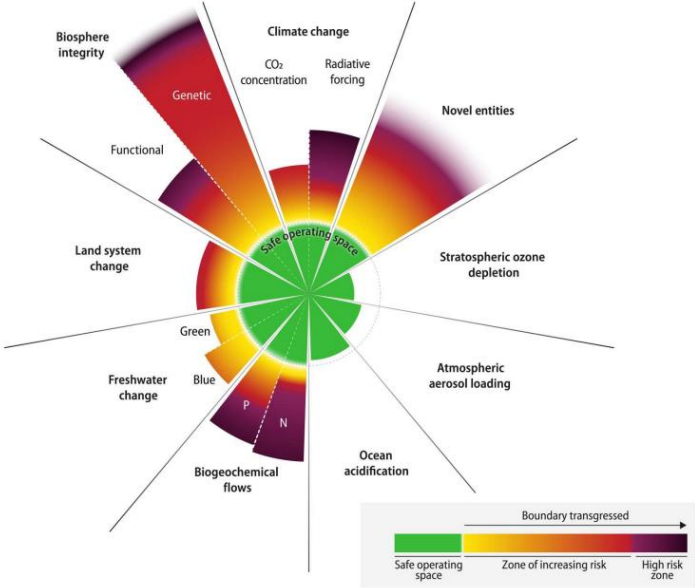

Fig. 2.2. Current status for all nine planetary boundaries [9].

In 2015, Bjørn et al. proposed linking the planetary boundaries framework with LCA, an integration that introduced the concept of "absolute sustainability," aiming to measure whether human activities remain within the safe limits defined by the planetary boundaries. This approach represents an ambitious effort to ensure that products and processes are sustainable on a global scale [11].

The planetary boundaries framework has since become an essential tool for scientists, policymakers, and sustainability practitioners. It provides a clear set of guidelines for maintaining the stability and resilience of Earth's systems, helping to guide global efforts in addressing the growing environmental challenges posed by human development.

2.2. Sustainability in food supply chains

The environmental and social impacts of the food industry and food supply chains are multifaceted and complex, and extend across the entire spectrum of the supply chain, from production to consumption, as discussed and shown during this work. The food and beverage industry is distinct due to its heavy dependence on extensive land use and other resource-intensive materials. Approximately 70% of the land area in the European Union (EU) is covered

by forests or used for agriculture, meaning that production activities in this sector significantly influence the preservation of natural capital, the quality of life, and employment opportunities in rural areas. Therefore, enhancing nature in this sector can lead to notable benefits in both environmental and social aspects.

In a regional context, the food and beverage industry plays a central role in the EU's economy, accounting for approximately 12.8 % of the added value in manufacturing and comprising over 280,000 businesses that provide jobs to more than 4.3 million individuals [12], [13]. In 2012, this sector generated over €1,000 billion in revenue, equivalent to 14.6 % of the EU's total manufacturing sector, making it the most significant contributor. Furthermore, it added over €200 billion in value, representing 12.5 % of the EU's entire manufacturing sector [5].

The supply chains within the food and beverage sector encompass numerous companies from various industries and sectors of the EU's economy, characterized by their complexity. This complexity stems from the reliance on many raw material inputs that companies process through several stages across diverse sectors, including agriculture, livestock, aquaculture, food processing, packaging, logistics, waste treatment, and disposal. Additionally, these supply chains are marked by significant intricacy due to stringent hygiene and refrigeration requirements, which substantially impact energy consumption and consequently put additional pressure on resource use and other environmental issues [14]. Hence, implementing energy-saving measures in the food and beverage sector supply chains can yield benefits across a wide array of economic sectors.

The lengthening of FSCs, driven by globalization, has led to increased environmental impacts due to higher resource use, energy consumption, and emissions. Carbon labeling and food miles initiatives aim to address consumer awareness, but their scope is limited. Food losses, impacting society, environment, and business, are exacerbated by challenges in food safety and perishability, with significant waste occurring at various FSC stages [15], [16], [17].

International organizations like the Food and Agriculture Organization of the United Nations (FAO), WFP, and UNEP are working towards reducing food losses and waste, which is crucial for environmental and social sustainability. Technological innovations in storage and monitoring are crucial for enhancing food safety and minimizing waste. Recently, the role of consumer perceptions in driving changes towards sustainability, with a growing concern for ethical issues beyond food safety, has pushed for further considerations towards a more holistic FSC management [18], [19].

High private standards in food retail contribute significantly to waste, particularly in fresh food supply chains. The scale of food waste, with substantial losses at the consumer end, calls for effective strategies in food waste recovery and side-stream valorization. Addressing these issues is vital for achieving the sustainable development goals (SDG), mainly Target 12.3 on reducing food waste by 50 % by 2030 [20], [21], [22].

Supply chain management (SCM) has become a cornerstone in reducing food waste and losses. However, SCM has also been recognized for its largely untapped potential in reducing environmental and social impacts, evolving from a purely economic performance focus to an integrated approach that encompasses social and ecological aspects. This holistic approach

addresses responsibility and ethical issues in the downstream flows of goods (towards the consumer) and environmental concerns in upstream flows (towards the supplier) [23].

Current research trends and methodologies use a qualitative approach, with case study analysis being the most common method. These studies explore various sustainability issues, focusing on supplier management, sustainable development, and collaboration and coordination management [23], [24]. Many studies in SCM do not follow a specific theoretical framework, indicating that this research field is still emerging [23], [25], and there is a need for more in-depth investigations to better understand FSC sustainability, especially in developing countries where infrastructure and logistics inefficiencies can lead to more FW.

In summary, the food industry's environmental and social impacts and supply chains are complex and require a multi-dimensional approach for effective management. The focus has gradually shifted from traditional production-centric models to more holistic ones that incorporate environmental and social considerations. However, there is a need for further research and a more comprehensive understanding of these impacts, especially in the context of developing economies.

2.3. Overview of sustainability methods in food supply chains

A systematic literature review on sustainability evaluation in the food industry, specifically in FSCs was conducted following the PRISMA-2020 protocol for systematic literature reviews [26].

Studies on the sustainability of food systems (including agriculture) have gained more attention in recent years, and there is a rise in popularity among consumers, producers, and policymakers, as seen in Fig. 2.3 and Fig. 2.4 [27]. Additionally, sustainability research in engineering, social sciences, business management, and economics (although economy is a social science) covers a good part of sustainability-related research, as found in the bibliographic screening conducted in this project (see Fig. 2.3).

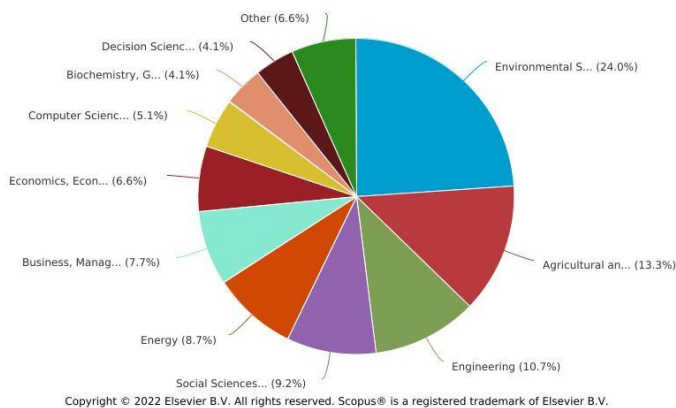

Fig. 2.3. Documents by subject area.

As observed in Fig. 2.4, investigations of sustainability in FSC have risen in the last few years. Fourteen documents matching the defined string search in the Scopus database were found for 2021 and 2022, showing an increase of 250 % compared to the last decade.

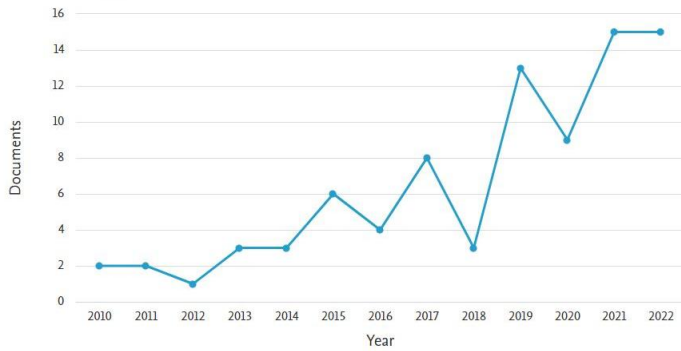

Fig. 2.4. Documents by year.

Fig. 2.5 displays the main keywords in the investigated documents, and their links are given by co-occurrences with other keywords. Forty-one keywords appear in the 84 papers, with 131 co-occurrences 166 times. The bigger the frames and font for a specific keyword, the more co-occurrences with other document keywords. The particular colors within the network allow us to identify the most cited keywords among all the documents, with “climate change”, “food supply chains”, and “supply chains” being the most cited, followed by “life cycle assessment”, “sustainability”, “system dynamics”, and “food manufacturing”.

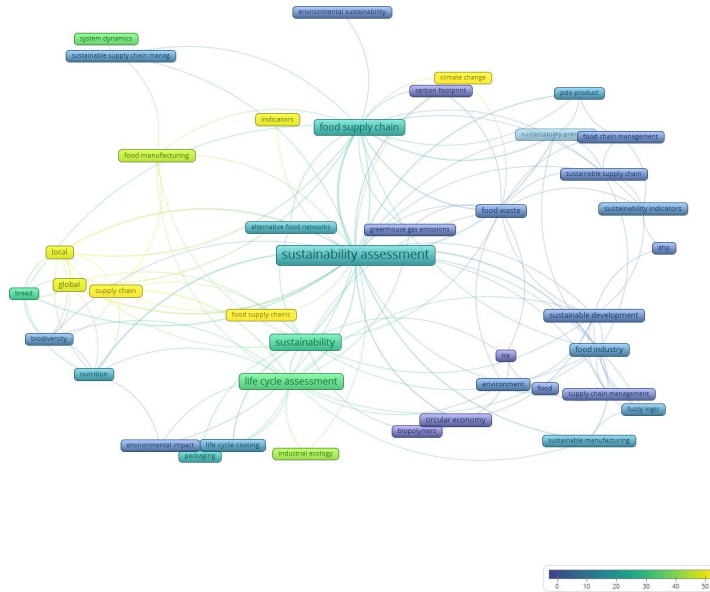

Fig. 2.5. Keywords network by citations.

Fig. 2.6 shows the main keywords when the co-occurrence is higher than 3, meaning these topics are often researched in conjunction. “Sustainability assessment” with 25 co-occurrences was investigated along with “food supply chain”, “local”, “global”, “food industry”, and “nutrition” topics from 2016 to 2020.

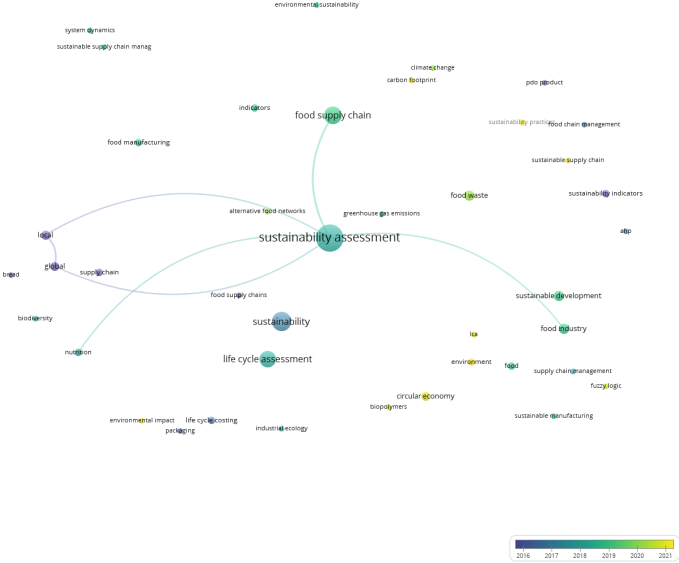

Fig. 2.6. Highest co-occurrence score network.

An easier way to spot those most investigated topics represented by keywords is the heat map in Fig. 2.7. This density visualization demonstrates the topicality of combining sustainability assessments in food supply chains with life cycle assessment methodologies.

However, bibliographic analysis and bibliographic findings, although fundamental to understanding the main concepts within a research topic, are just an initial screening of the state-of-the-art scientific literature. Hence, a deep content analysis of the identified literature is a cornerstone in systematic reviews.

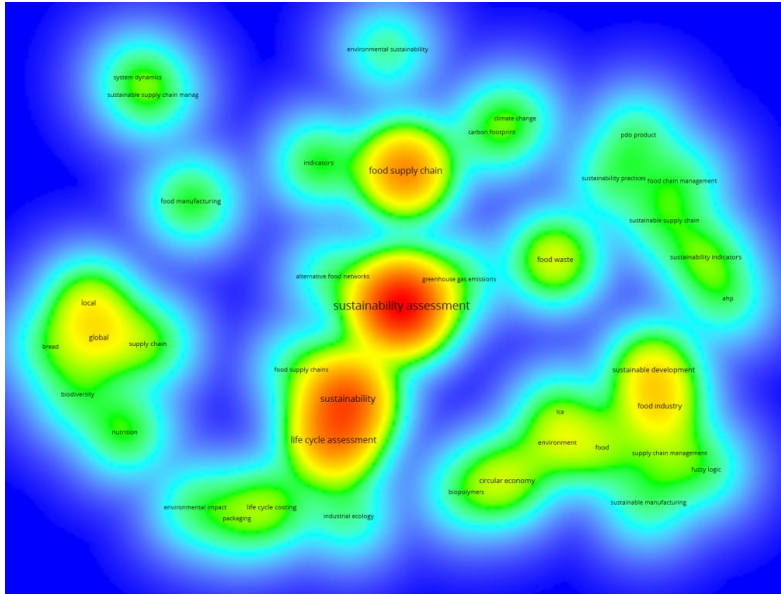

Fig. 2.7. Bibliographic density map.

Utilizing *Research Rabbit*, an artificial intelligence tool, an expansion on relevant and updated literature was performed, as shown in the Fig. 2.8. After a record screening following the PRISMA methodology for systematic literature reviews, the final number of documents included in the content analysis was 95 [28].

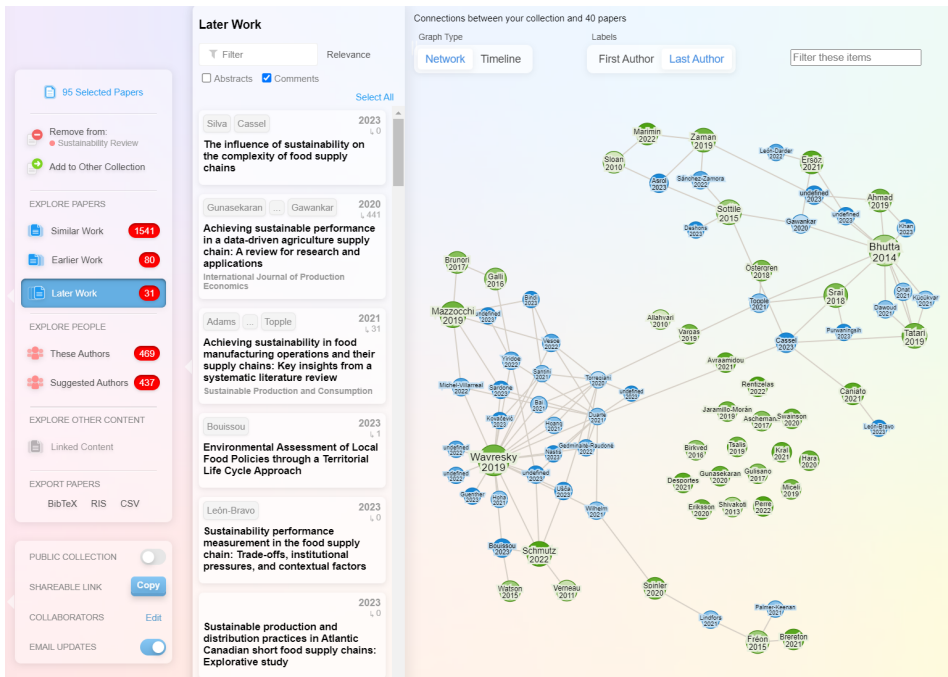

Fig. 2.8. Literature expansion for content analysis.

2.3.1. Content analysis.

Recent studies have highlighted the complex impact of food chain configurations on health and sustainability, underscoring the interconnection between dietary choices and environmental outcomes. A multidimensional approach to sustainability assessment has been advocated, integrating a blend of both “hard” LCA and “soft” qualitative methods. This would ensure a comprehensive coverage of sustainability's broader impacts, including often-overlooked aspects like human health [29]. Brunori et al. (2016) employed a robust methodology, incorporating media analysis and a Delphi survey to establish 24 sustainability attributes, assessed through a multifaceted lens that spans ethical considerations to interspecies equity [29]. Their expansive study examined 39 case studies across varying supply chains and commodities to measure sustainability performance in a cross-country context. Crucially, the research highlighted the contextual nature of food supply chains' performance, challenging the oversimplified dichotomy of local versus global supply chains by revealing that sustainability performance is nuanced and highly dependent on specific attributes and context. This complexity indicates that there is no universal “best performing” chain, and instead, a nuanced understanding of each chain's attributes is necessary for an accurate sustainability assessment.

Ahmad and Wong (2019) have identified that while most existing sustainability assessment methods in manufacturing predominantly focus on environmental concerns, the food sector's substantial contributions to GHG emissions, water usage, and waste production necessitate a more comprehensive approach [30]. Additionally, the industry's influence on nutrition and public health is significant, with processed foods contributing to detrimental dietary patterns. Thus, their research advocates for a holistic sustainability assessment.

Considering the consolidated list of 95 papers, a content analysis was conducted to understand the current state of the art in the topic. First, the papers were grouped by the employed method, as presented in Table 2.1. It can be observed that LCA is the preferred methodology for assessing sustainability features in FSC. The share per method utilized in FSC sustainability assessment in the analyzed sample can be seen in Fig. 2.9.

Table 2.1. List of methods in FSC sustainability assessment.

Method	# of papers	Reference
LCA based methods	26	[31], [29], [32], [33], [34], [35], [36], [37], [38], [39], [40], [41], [42], [43], [44], [45], [46], [47], [48], [49], [50], [51], [52], [53], [54], [55]
System dynamics-based methods	2	[56], [57]
Qualitative evaluations	6	[58], [59], [60], [61], [62], [63]
Fuzzy logic-based methods	6	[30], [64], [65], [66], [67], [68]
Literature reviews	15	[25], [58], [69], [70], [71], [72], [73], [74], [75], [76], [77], [78], [79], [80]
Multi-criteria decision making (MCDM)	3	[51], [53], [68]
Comparative analysis	2	[29], [81]
Case study-based methods	5	[27], [82], [83], [84], [85]
Indicator-based evaluations	3	[86], [87], [88]
Descriptive/qualitative analysis	1	[89]
Econometric/statistical models	3	[90], [91], [92]

LCC and other life cycle tools	4	[38], [48], [55], [93]
Bibliometric analysis and PRISMA	4	[24], [70], [75], [94]

In general, the content analysis shows that LCA has several key advantages. One of the most significant advantages is LCA's comprehensive scope, which enables a detailed evaluation of environmental impacts throughout the entire life cycle of a product, from raw material extraction to disposal. This holistic approach enables the identification of critical stages within supply chains where sustainability improvements can be made. By considering both environmental and economic data, LCA tools enable informed decision-making and inform policy, providing valuable insights for both industry and regulators. Many papers note how LCA's standardized approach facilitates comparisons across different products, industries, or regions, providing a robust foundation for decision-making in policy and corporate sustainability efforts.

LCA is frequently praised for its ability to assess multiple environmental impacts, including greenhouse gas emissions, resource use, and waste generation. This comprehensive analysis helps businesses identify areas for improvement, such as reducing food waste, optimizing resource efficiency, or lowering emissions. LCA is also valuable for scenario analysis, aiding in long-term planning and sustainable product design while supporting the transition to a circular economy. Its adaptability across sectors like food, energy, and manufacturing highlights its versatility in addressing various sustainability challenges.

LCA also provides broader sustainability strategies by integrating circular economy principles, waste management, and resource optimization. It helps pinpoint supply chain hotspots contributing to environmental degradation, making it a useful tool for targeted improvements. Additionally, LCA encourages innovation in product design by promoting sustainability at every phase, driving the development of eco-friendly technologies and practices. This capacity to foster systemic change is a key benefit noted throughout the literature.

A common drawback of using LCA is its complexity and data limitations. LCA requires large datasets for each life cycle phase, which can be difficult to obtain, especially in regions with limited access to reliable data. Data gaps, particularly in areas like biodiversity or soil carbon impacts, create uncertainties that can affect the robustness of results. Additionally, LCA tends to focus on environmental factors, often neglecting socio-economic aspects, reducing its effectiveness as a comprehensive sustainability tool.

Another limitation is the high computational complexity and cost, which makes LCA less feasible for smaller companies or industries with limited automation. The initial investment in time and financial resources can be a significant barrier, especially in sectors with variable or uncertain data, such as food production or developing regions. LCA also struggles with capturing localized environmental and social effects, meaning findings may not easily apply across different regions or sectors, limiting the generalizability of results for broader sustainability measures.

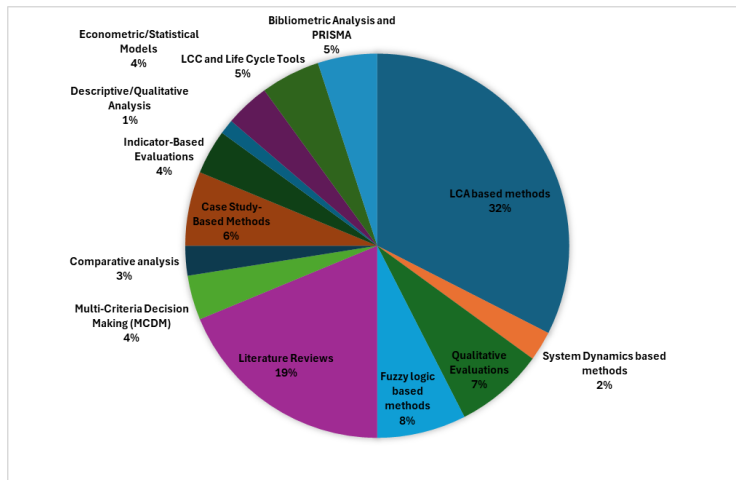

Fig. 2.9. Sustainability assessment methods in FSC.

Another typical method used for FSC sustainability assessment is qualitative evaluation. These methods promote stakeholder participation and interdisciplinary collaboration, which is particularly beneficial for diverse agri-food systems. They provide a comprehensive evaluation across socio-cultural, agro-environmental, and economic dimensions, often emphasizing the benefits of local food systems regarding consumer-producer trust, short supply distances, and economic resilience. Qualitative approaches also provide actionable recommendations for enhancing sustainability in food value chains, making them adaptable across various sectors while fostering a comprehensive understanding of sustainability.

However, there are challenges in quantifying qualitative indicators, and further refinement is needed for broader application to other agri-food systems. These methods are often limited to small-scale systems with specific local product chains, making scalability an issue. Environmental sustainability may also be harder to achieve in local systems due to higher transportation impacts per unit, and the production scalability remains constrained. Additionally, qualitative methods, such as checklists, require context-specific adaptation and may not fully capture the complex trade-offs in larger, more industrialized supply chains.

Fuzzy logic-based methods are widely used in sustainability assessments due to their ability to handle uncertainties and combine qualitative and quantitative data, making them suitable for complex decisions. They often include social, environmental, and economic indicators, helping eliminate bias through multigrade fuzzy models and facilitating organizational comparison. These methods also help identify key performance indicators (KPIs) for assessing and improving circular and sustainable practices in supply chains.

However, these methods face challenges, such as subjectivity in weighing indicators, which can introduce biases. Inconsistencies with life cycle impact assessment (LCIA) methods may limit the replicability of results, and applying these methods often requires customization. Furthermore, their focus on environmental aspects sometimes excludes profitability and social sustainability, reducing comprehensiveness. Data collection and expert involvement can also be resource-intensive.

Research suggests combining fuzzy logic with other techniques, like Monte Carlo simulations, to better account for uncertainties in sustainability evaluations. Stakeholders play a crucial role in improving sustainability in areas such as waste management and energy efficiency, although trade-offs, like increased water consumption from circular practices, must be considered.

The conducted content analysis also highlights the importance of conducting case study-based assessments. One key finding is the development of decision-making tools, such as roadmaps, to monitor and plan sustainability progress across multiple levels. These studies reveal that companies primarily focus on meeting regulatory requirements, driven by pressure from stakeholders such as customers, communities, and regulatory bodies. Sustainability practices and assessments often vary based on the perceived importance of these stakeholders, and case studies show that the roadmap serves as a valuable tool for aligning sustainability practices across supply chains.

Another finding highlights the role of eco-intensity methods in improving environmental sustainability by reducing energy consumption, greenhouse gas emissions, and solid waste. In specific cases, such as the Grupo Nutresa case, companies need to specialize their business models and leverage international sales to enhance sustainability recognition. Case studies also highlight the challenges of integrating sustainability into food value chain design, particularly in terms of biodiversity, energy, and social equity. Shortening food supply chains can enhance social sustainability and food security, but may not automatically address environmental challenges. Moreover, while global sourcing can improve transparency, there is significant variability in sustainability practices and compliance across suppliers. Farms that adhere to sustainability standards gain market access and community support; however, scaling production while maintaining sustainability remains a significant challenge.

Finally, several papers included in the analysis do not reference the sustainability of FSCs or sustainability methods, but rather focus on specific food aspects, such as nutritional content or physicochemical characteristics.

2.3.2. Industry-level sustainability evaluation methods

Despite its aged definition in the Brundtland report, sustainable development plays a critical role in industrial decision-making [2]. Various sustainability assessment methodologies have been developed to evaluate company performance, with significant contributions from the World Business Council for Sustainable Development [95], the Global Reporting Initiative [96], and standards developed by the OECD [97].

There is also a growing recognition of indicators and composite indicators as essential tools in policy-making and public communication, especially in assessing environmental, economic, societal, and technological performance [98]. These indicators arise from and create values, condensing complex environmental information into manageable and meaningful data [99], [100], [101], [102]. A growing need for models, metrics, and tools to articulate current unsustainable activities poses critical questions on integrating and extending operational systems for monitoring environmental and social conditions [102]. Other studies have also

emphasized the purpose of sustainability assessment: to provide decision-makers with evaluations of integrated nature-society systems to guide actions toward sustainability [103].

Consequently, companies address the sustainability issue in various ways and approaches. While some focus on the so-called carbon footprint, such as the chemical industry following the Together for Sustainability (TfS) framework, others evaluate their sustainability performance using the environmental, social, and governance (ESG) frameworks. TfS is a member-driven initiative to raise corporate social responsibility (CSR) standards in the chemical industry. It focuses on improving sustainability within chemical companies and their suppliers, building a global standard for the carbon footprint performance of chemical supply chains. TfS claims to support and coordinate the sustainability performance measurement of chemical companies and their suppliers. However, regarding environmental quantitative evaluation, TfS only evaluates GHG emissions, disregarding all other pillars and dimensions of sustainability [104].

A more widespread framework is the ESG scoring framework. ESG gained popularity in 2000 when sustainable investing became a hot topic, and companies started to disclose the impact of climate risks on their business models [105]. The 2000s saw the establishment of the United Nations global compact and the carbon disclosure project (CDP), which focused on corporate responsibility and climate performance reporting. In 2004, the "Who Cares Wins" report coined the term ESG, advocating for its integration into investment decision-making [106].

ESG disclosure through an ESG report has slowly become synonymous with sustainability reporting, and more companies have jumped onto the bandwagon of ESG scoring. ESG has become crucial for companies disclosing sustainability reports. It encompasses various concerns, from climate change and environmental stewardship to social justice, labor practices, and corporate governance. The ESG framework guides companies in identifying and managing risks and opportunities related to sustainability.

Nonetheless, disclosing an ESG performance score for rating providers does not necessarily translate into a sustainability performance or profile. ESG reporting was never intended to provide a sustainability picture; instead, to supply investors with ESG information for them to make decisions considering only financial sustainability derived from the level of exposure of a company to environmental and social risk, and in some cases, the level of damage caused by the company to some environmental regions of concern [107], [108].

Other industries, especially in the European context, are paying particular attention to the new CSDR, an ambitious directive aiming to standardize ESG and sustainability reporting while incorporating additional environmental areas of concern and a robust social evaluation. The emergence of regulations like the EU's sustainable finance disclosure regulation and the CSRD demonstrates the growing regulatory focus on ESG disclosure. These require companies to report on their sustainability practices, aligning with broader ESG and SDG objectives. The CSRD, enforced in 2023 by the European Commission, aims to introduce a mandatory scope to the voluntary disclosure of sustainability-related aspects [109]. Although the new legislative package is more comprehensive in scope, it needs more depth in its framework. Moreover, the document does not intend to evaluate the sustainability performance of a company or a product,

but rather to disclose certain aspects commonly related to sustainability, including both quantitative and qualitative aspects [110].

Other tools exist for different industries to address the issue of sustainability from a product perspective, rather than a company scoring approach. The construction sector leads the way in this matter with the early adoption of EPDs as part of several sustainable construction frameworks in different regions of the world (BREAM, LEED, GreenStar, etc.), pushing for understanding of the life cycle environmental impact of materials going into construction elements [111].

An EPD is a certified and registered document that provides transparent and standardized information on the environmental impact of products throughout their life cycle. The international EPD system is a worldwide initiative focusing on environmental declarations, developed in accordance with ISO 14025, TS/14027, 14040, and EN 15804 standards. Their database currently holds over 10,000 EPDs, which hundreds of companies have registered across many countries. Having an EPD for a product does not mean the declared product is more environmentally advantageous than other options. It is a clear and explicit statement on the environmental impact throughout the life cycle. ISO 14025 is the applicable standard for environmental product declarations, specifically known as “type III environmental declarations”. A type III environmental declaration is generated and officially recorded within an EPD program operator. An EPD has numerous applications, including facilitating green public procurement (GPP) and assessing the environmental performance of buildings.

Several types of EPDs exist, each offering different levels of data specificity. Industry-wide EPDs should present statistical data for transparency and accuracy. Facility- and product-specific EPDs are vital for policy compliance and should be based on harmonized universal background datasets. Nevertheless, EPDs face challenges in standardization and adoption, including high upfront costs for small businesses, inconsistencies in EPD development, and a need for universal public databases for reference. Additionally, EPDs focus only on environmental impacts, disregarding the financial and social sustainability pillars. Therefore, EPDs, although widely accepted as a product environmental performance tool, cannot be considered a comprehensive product sustainability evaluation.

All these corporate and product sustainability evaluation frameworks and methods have two things in common: i) the need for impact contextualization and missing sustainability attributes in different pillars, and ii) they can be highly time and resource-consuming. While the former issue is more complex to tackle, as it requires a level of commitment that large corporations are still reluctant to accept, the latter has led to a new wave of LCA software and tools with more user-friendly interfaces, in an attempt to engage more actors in the LCA methodology as a product sustainability tool.

Classic LCA software, although decisive in calculating environmental impacts using different LCIA methods, needs more flexibility to respond rapidly to the diverse needs of different industries. While SimaPro, for instance, does not graphically allow for product system visualization, GaBi, the second-largest LCA software, does not enable consequential or allocation at the point of substitution evaluations, which is crucial for research activities. A

primary drawback of most commercial LCA tools is the need for greater capability to observe how impact assessment responds in real-time to changes in the life cycle inventory (LCI).

Despite the latest efforts to simplify the complexity of the LCA methodology and the expertise required to operate the leading commercial LCA software correctly, new solutions still need to overcome several barriers, especially for SMEs. Only a few significant entry prices were added to the need to purchase learning packages to get acquainted with the tool. Another potential problem with the recent LCA tools is the cloud-based system most offer, as companies may view it as a risk for their sensitive data (foreground data) in the event of a cyber-attack on LCA servers. Finally, these new LCA cloud-based tools still require the company to utilize the service to access an LCA expert who can address the complexities of specific system boundary designs, such as EPDs, cut-off criteria, and allocation factors.

To successfully promote and accelerate the use of sustainability assessment tools, they need to overcome the barriers mentioned above. They should be easy to use, without excessive entry fees, visually engaging, and allow data exporting features. They should also focus on inventory collection and reporting organically, permitting sustainability professionals with a basic LCA understanding to navigate them and obtain accurate and timely results.

2.4. Food supply chain considerations

Given the FSC expansion, the likelihood of safety-compromising hazards at any stage, potentially jeopardizing the integrity of the entire chain, has escalated [115]. Several factors contribute to the lengthening of the FSC. Primarily, the global population's growth has fueled an upsurge in food and goods production, necessitating the globalization of the FSC. This phenomenon has spurred innovations in transportation and cold storage technologies. The relaxation of trade barriers and increased international trade agreements have further amplified this trend.

Efforts to educate consumers about their food's environmental impact have emerged, such as carbon labeling and 'food miles' [112]. Carbon labeling, which displays a product's carbon footprint on its packaging, only partially encapsulates the entire environmental load of the supply chain due to its dynamic nature and variable transportation distances [113]. Additionally, societal attention is increasingly drawn to the natural resources and energy lost through food waste [114].

Addressing safety issues in food is a crucial strategy to minimize loss and waste. Technological advancements in temperature control, energy-efficient storage, new packaging materials, and smart monitoring systems are among the key measures [115]. The consumer demand for high-quality, environmentally friendly products has catalyzed changes towards reducing food waste while sustaining food quality [116].

Consumer food quality and safety expectations significantly influence FSC management [117]. Quality is not just about product features; it also encompasses customer perceptions and satisfaction of needs, including environmental and ethical considerations [118]. Research explores the relationship between quality perception and short supply chains, with a growing consumer preference for locally produced, organic food [119].

Recent literature defines food quality as sensory attributes like size, texture, flavor, and hidden attributes related to safety and nutritional value [120]. Balancing safety, quality, and efficiency is difficult, given the low profitability in the food industry and the escalating public concern over FW. Food waste, which comprises nearly one-third of all food production, is a significant environmental and social burden. Temperature management failures alone can lead to substantial product loss, increased operational costs, and strained supply chain relationships.

It is essential to differentiate between food loss and food waste. At the same time, the latter refers to discards at the consumer or retailer level; the former includes any food removal from the supply chain. Food loss recovery processes include bio-energy production, composting, and anaerobic digestion.

The FAO defines food waste as food fit for consumption but discarded due to negligence or a conscious decision [121], [122]. While the quantity and quality of food losses vary, comprehensive data is necessary to ensure accurate estimations [123]. Food waste in FSCs is challenging to measure due to the involvement of multiple actors and diverse causes, and is a significant issue in food security, sustainability, and climate change [124].

Retailers, while addressing food waste, often reject edible food based on visual standards, contributing significantly to waste in fresh food supply chains [124], [125], [126], [127]. In China, consumer stages, including households and restaurants, are significant contributors to food waste, contrasting with the EU scenario, where households are more responsible [128], [129].

On the other hand, FW at the consumer end is mainly due to quality degradation, expiry, or damage during handling [130], [131]. Reducing waste through efficient quality monitoring and addressing the preference for fresher batches in retail settings can mitigate this issue [132].

The extent of food waste, varying between 25 to 40 % in different markets, highlights the distribution challenges rather than scarcity as a primary driver of hunger [133], [134]. It is estimated that about 30 % of global food production is lost in the FSC, with higher percentages in specific regions like the USA [135]. The FAO reported in 2011 that 1.3 billion tons of food products were wasted annually worldwide, with significant losses occurring at various FSC stages [136]. The nutritional loss in calories is estimated at nearly 48 % of the total produced [22]. Addressing food loss is crucial for global sustainability, environmental impact, human health, and resource conservation [137].

Regarding climate change, the focus is often on clean energy solutions, missing that the food system, including production, processing, and distribution, significantly contributes to GHG emissions, accounting for about 26 % of global emissions [138]. The key contributors to food GHG emissions are broken down into four categories: i) livestock & fisheries (31 % of food emissions): this includes emissions from ruminant livestock like cattle, which produce methane through enteric fermentation, as well as emissions from manure and pasture management, and fuel consumption from fishing vessels [138]; ii) crop production (27 % of food emissions): direct human consumption of crops accounts for 21 % of food emissions, with the remaining 6 % from the production of animal feed. These emissions stem from the application of fertilizers and manure, methane from rice production, and CO₂ from agricultural machinery; iii) Land Use (24 % of food emissions): this involves the conversion of forests,

grasslands, and other carbon sinks into cropland or pasture, leading to significant CO₂ emissions. Livestock-related land use accounts for more emissions (16 %) than crops for human consumption (8 %). And iv) Supply chains contribute to 18 % of food industry emissions overall. This category encompasses emissions from food processing, transportation, packaging, and retail. Transport emissions account for a small percentage (6 %) of global food emissions. However, food supply chain emissions are crucial in reducing food wastage, a significant source of emissions [139].

2.4.1. Additional sustainability considerations

The environmental implications of FSC activities are direct and indirect. Direct impacts stem from the consumption of resources and emissions within the system boundaries of a supply chain, relating to the utilization of raw materials, energy, and other intermediate products essential for the processes involved.

For instance, refrigerants are widely used in the FSC, including cold storage, refrigerated transport, and supermarket display cabinets. However, their environmental impact, particularly ozone depletion, has led to restrictions in recent decades. Ozone layer depletion is attributed to chlorofluorocarbons (CFCs), which possess a high ozone depletion potential (ODP). The 1988 Vienna convention for the protection of the ozone layer set a deadline for phasing out CFCs. In China alone, phasing out CFCs in domestic refrigerators between 2008 and 2011 has reduced CO₂ eq emissions by approximately 619.8 million tons and ODP emissions by 100,000 tons [140]. Hydrochlorofluorocarbons (HCFCs), which replaced CFCs, have a lower ODP but a higher global warming potential (GWP), exemplifying the shifting burden in quantitative environmental assessments. This switch to HCFCs could exacerbate climate change, potentially increasing natural disasters like hurricanes and floods, and impacting biodiversity [141].

Beyond direct impacts, the indirect effects of unconsumed food (food loss and waste) are significant. In carbon footprint terms, food waste is estimated at around 3.3 Gt CO₂ eq, ranking it the third largest source of carbon emissions after the USA and China, compared with direct national emissions [121], [141]. In the freshwater usage category, food wastage accounts for approximately 250,000 m³, equivalent to the annual water discharge of the Volga river, Europe's longest river [121]. Each ton of wasted food contributes approximately 4.5 tons of CO₂ to the atmosphere, and food waste in landfills generates methane, a greenhouse gas that is far more potent than carbon dioxide.

The land footprint of unused food is also staggering, occupying approximately 1.4 billion hectares, nearly one-third of the world's total agricultural area. To meet the projected food demand of the 2050 global population, production needs to increase by 60 %. However, reducing food waste could eliminate the need for such an increase [121].

Reducing food waste is crucial for conserving resources and curbing emissions, enhancing ecosystem quality, ensuring overall environmental protection, and ensuring food security for humanity. The FSC faces regulatory and environmental challenges, such as increased traceability and packaging quality measures. These regulations are not universal, adding complexity to FSC management, particularly in international contexts [142], [143].

Environmental pressures drive sustainability concerns in the FSC, particularly waste reduction and packaging reuse [144]. These concerns affect not only environmental aspects but also social stakeholders and the development of corporate social responsibility initiatives [145].

Sustainability in the FSC, particularly in agriculture, is gaining prominence due to its holistic benefits. The food industry's intrinsic relationship with sustainability is evident, given its extensive use of natural resources, its role in human nutrition, and the dependence of communities on food for survival. As noted by Soysal et al., the unique characteristics of food products necessitate additional logistics efforts due to quality and environmental concerns [146]. This highlights the need for decision-making tools integrating economic, food quality, and ecological challenges in FSC sustainability management.

Sustainability is a multifaceted concept in literature with various definitions, which makes measuring its performance in the FSC challenging due to the inclusion of environmental and social indicators, which are often difficult to quantify, alongside economic factors [147].

Typically, sustainability assessments focus on one or two environmental pillars or a combination of economic and environmental factors. Environmental performance indicators include energy and resource use, carbon emissions, waste production, and ecosystem quality. Economic indicators may include profit or the internal rate of return. Social performance evaluations may encompass stakeholder engagement, human rights, and occupational safety, but these take more work to measure [148].

Research on the environmental sustainability of industries, particularly the food industry, is available, as are studies on social and economic aspects focusing on improving product quality and cost-effectiveness [149], [150], [151], [152]. Improvements in sustainability across the food supply chain require collaboration among all actors [153]. As the FAO states, achieving sustainability in the food industry necessitates global engagement to address consumer expectations, policies, regulations, and resource limitations [18].

In the EU, natural resource use, storage, and transport in the FSC are essential to sustainable development. Sustainability outcomes encompass fulfilling social needs, achieving economic gains, maintaining ecological quality, promoting well-being, and creating new business opportunities. However, research on sustainability in the FSC still needs to be expanded [154]. Some studies, such as Mangla et al. (2018), have explored the drivers for implementing sustainability in the FSC using varied methodologies. However, quantitative environmental impact assessments for FSC sustainability still need to be explored [70], [155].

2.5. Research gaps

In the current era of environmental awareness and sustainability challenges, the need for tools that can accurately assess and guide sustainable practices has become paramount. Traditional methods of evaluating environmental impact often focused on immediate outcomes or singular aspects of a product's life, which are no longer sufficient to capture the complexity of sustainability. This is where life cycle thinking emerges as crucial, offering a holistic approach that considers the entire spectrum of a product or service's impacts across its life cycle. Unlike traditional "cradle-to-grave" assessments, LCT adopts a more comprehensive

“cradle-to-cradle” perspective, evaluating stages from raw material extraction through production, use, and end-of-life, while also identifying opportunities for circularity and innovation.

Despite its conceptual strength, the integration of LCT into practical, user-friendly, and sector-specific tools remains underdeveloped, creating a significant research gap. Current tools often lack comprehensive data, have limited adaptability to industry-specific needs, or present steep learning curves that exclude many practitioners, particularly SMEs. As a result, there is a clear opportunity to bridge the divide between academic methodologies and industry application by developing a robust, accessible decision-support tool grounded in life cycle principles. Such a tool would not only enhance understanding of sustainability metrics but also promote actionable change by enabling stakeholders to identify sustainability hotspots, implement targeted interventions, and evaluate trade-offs between environmental, social, and economic outcomes.

The literature review undertaken in this thesis highlights several critical gaps that inform the definition of the research problem and objectives:

1. Bridging theory and practice. Although LCT is well established, existing approaches remain largely conceptual or research-oriented, with limited translation into tools that can be readily applied in real-world decision-making.
2. Integration of multi-dimensional sustainability. Most existing tools focus narrowly on environmental aspects, while neglecting or insufficiently integrating the economic and social dimensions required for a comprehensive assessment aligned with the SDGs, CSRD, and ESG frameworks.
3. Industry-specific contextualization. Generic frameworks often fail to address the specific sustainability challenges of food supply chains, including perishability, energy-intensive refrigeration, and high rates of food loss and waste. Tailored tools are needed to reflect these operational realities.
4. Operationalization of planetary boundaries and absolute sustainability. While acknowledged in theory, these concepts remain rarely applied in product- and process-level assessment tools, limiting their relevance for aligning supply chains with global sustainability thresholds.

Addressing these research gaps is essential for moving beyond fragmented, overly complex, or inaccessible methodologies. Therefore, the central research problem identified in this Thesis is the absence of a comprehensive, practical, and sector-specific LCT-based methodology that can be used consistently across food supply chains to assess and improve sustainability performance.

In response, the primary research objective of this thesis is to develop and validate a life cycle sustainability tool that operationalizes LCT by integrating environmental, economic, and social dimensions into a practical and user-friendly framework. By tailoring the methodology to the food industry and aligning it with global sustainability frameworks and policy requirements, this research seeks to provide a novel, accessible, and scalable contribution to both theory and practice.

3. METHODOLOGY

This Thesis aims to propose a novel approach for the sustainability assessment of food supply chains based on life cycle thinking methodologies to improve existing approaches, ensuring an expanded view of sustainability issues and allowing different actors across the FSC to collaborate for a less uncertain evaluation. The methods employed in this study follow a quantitative research approach, characterized by the stages involved, and are designed to test the central research hypothesis. A visual representation of the specific quantitative methodology followed is presented in Fig. 3.1. The methodology is divided into four main steps, from a research idea and problem definition to developing an LCST prototype and final reports, including the present document.

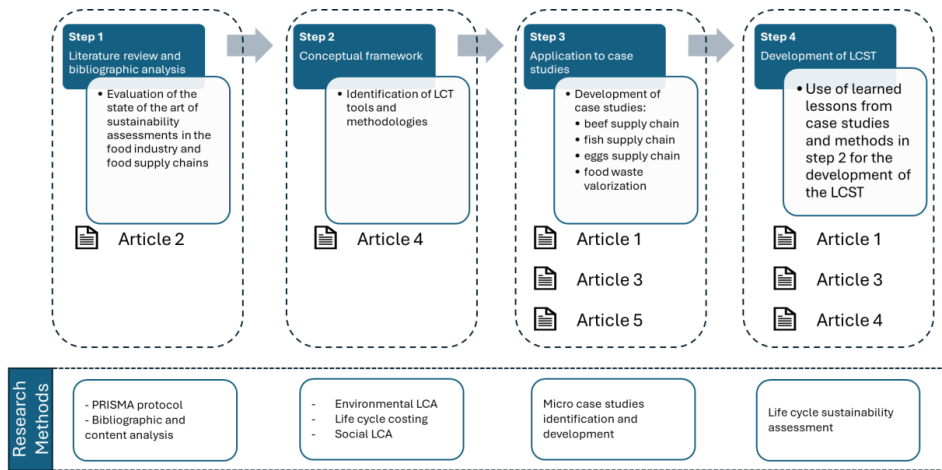

Fig. 3.1. Research framework and methods of the Doctoral Thesis.

After defining the research need based on a preliminary assessment of sustainability methodologies in the food industry, the problem was described in parallel with the development of the ICCEE project. Complementing the initial evaluation, the literature review phase was conducted to understand the current state of sustainability in the sector, followed by scoping the work and developing a hypothesis and main research objectives. It is worth noticing that some of these phases, although numbered for visualization purposes, do not necessarily happen in a strict sequence, and revisiting objectives and scope of work is a standard procedure in quantitative research methodologies [156].

During these phases, various food supply chains were evaluated to identify the primary hotspot activities in this type of product system. This was followed by the development of a comprehensive and dynamic tool to capture the intrinsic complexity of the supply chain while evaluating different sustainability attributes across multiple pillars.

Finally, the last two phases focus on the results from the case studies, improving the LCST, and testing and validating the tool. Based on those internal assessments, a final tool version was developed to deliver the results necessary to meet the intended study goals.

The present study employs a top-down approach, a research methodology that denotes a process in which the inquiry commences with a subject's most general, overarching facets and

progressively refines its focus to more specific features. This method is frequently implemented in economic analysis, scientific research, and the social sciences. A hierarchical procedure is employed, commencing with the most fundamental level of conceptual comprehension before delving into the more minute particulars.

Some key features of the top-down approach include:

- initiating from a broad perspective, research begins by examining overarching theories, frameworks, or concepts. The researcher progressively concentrates on increasingly particularized elements or case studies that exemplify or align with the frameworks above.
- theory-informed: established theories or hypotheses frequently influence the top-down methodology. Following the formulation of a theoretical framework or a set of assumptions, the researcher collects data or performs analysis related to these concepts.
- structured methodology: unlike bottom-up techniques, this approach is generally more methodical and follows a linear framework. There is a distinct hierarchical progression from the general to the specialized.
- macro-level analysis: initially, attention is directed to macro-level elements, encompassing broad trends, recurring patterns, or fundamental principles that regulate the field of inquiry.
- recommendations for subsequent research: the knowledge acquired from the preliminary, more comprehensive examination assists in influencing and delineating the trajectory of subsequent, more intricate inquiries.

A top-down methodology is often employed in policy research, where an investigator initially scrutinizes a nation's comprehensive economic policy, focusing on the distinct economic consequences within a single sector.

3.1. Research methods.

The research methods are described in the following sections.

3.1.1. PRISMA protocol

In this doctoral Thesis, the PRISMA protocol/methodology was followed to perform the bibliographic and content analysis presented in the Literature review section. A schematic representation of the undertaken method is shown in Fig. 3.2.

The PRISMA-P protocol aims to enhance systematic review and meta-analysis protocols' transparency, accuracy, and completeness, preventing arbitrary decisions and promoting thorough documentation. It helps in planning reviews, ensuring consistency, and enabling the assessment of selective reporting. The PRISMA-P checklist includes 17 essential items for systematic review protocols [28]. These guidelines are well-received by the research community and are designed to assist authors, reviewers, and funders in creating robust protocols. Recently, the PRISMA 2020 protocol has updated these guidelines to better align

with advancements in review methodologies, ensuring their continued relevance and adaptability [157], [158]. Feedback from users has led to several revisions of the PRISMA protocol, further refining its utility in systematic review practices [26].

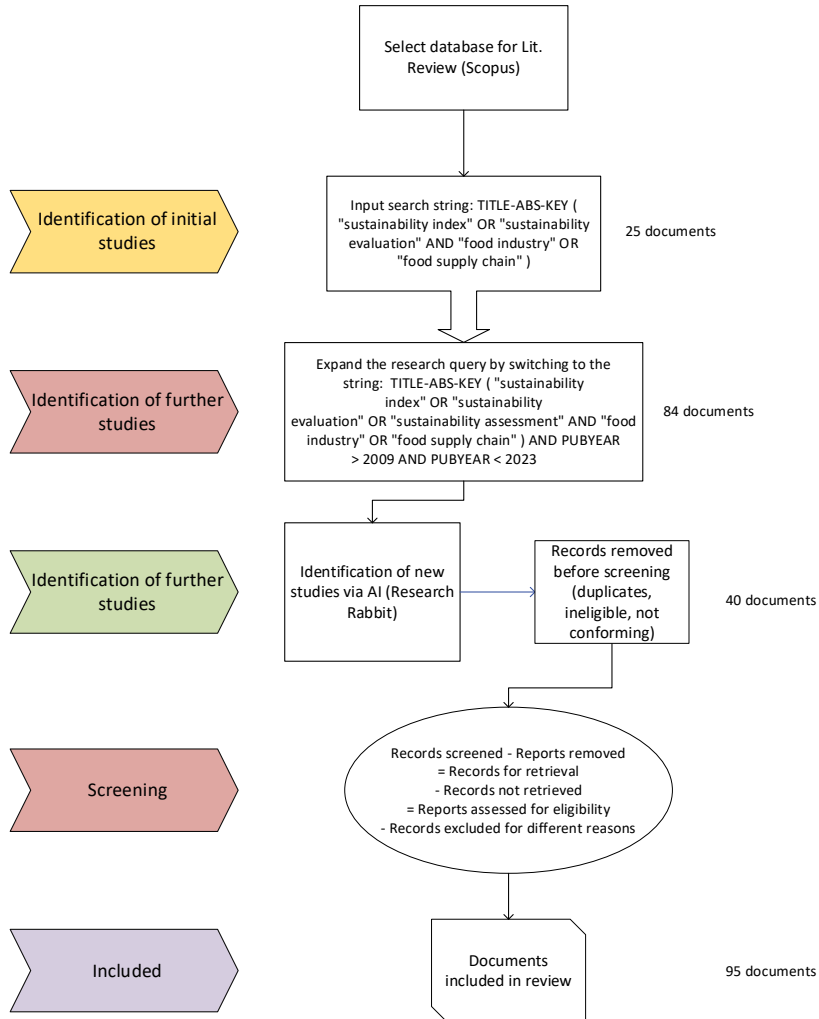

Fig. 3.2. Systematic literature review scheme following the PRISMA protocol.

3.1.2. Environmental LCA

Environmental LCA is vital for assessing products and processes' ecological impacts throughout their life cycle. LCA evaluates environmental efficiency across numerous impact categories, unlike carbon footprints, which focus on one ecological component [159], [160]. Global warming, resource depletion, and stratospheric ozone depletion are only some of the impacts or damage categories assessed [66].

The LCA methodology is based on ISO standards 14040:2006 and 14044:2006. Goal and scope definition, LCI, LCIA, and life cycle interpretation are the four stages of the LCA

process. This framework facilitates sustainable management decision-making by providing specific information on environmental impacts [161], [162]. Today, LCA addresses climate change, biodiversity loss, and pollution [163]. This trend expands LCA from product-level to economy-wide assessments, which is crucial for decarbonization, sustainable consumption, and the development of a circular economy [164].

Recent LCA advancements emphasize the integration of other environmental assessment methodologies for more comprehensive studies. However, standardization is needed to improve robustness and comparability [37], [164]. Linking LCIA results to planetary boundaries is becoming critical for understanding the agriculture and food industry sustainability [41], [165], [166]. An example is the work of Arias et al., who linked Planetary Boundaries with LCA in the wood-based bioadhesive industry, demonstrating the necessity of such integration for planetary environmental sustainability assessment [165].

Hence, adhering to Earth's safe and just limits, urging the engagement and coordination of stakeholders at various levels to establish and execute sustainable practices is recognized today as necessary [167]. This approach demands robust, transparent, and unbiased methodologies for translating across scales while acknowledging inherent assumptions, biases, and uncertainties [168].

The general framework followed when implementing the environmental LCA methodology during the case scenarios and for building the LCA structure within this research is described in accordance with ISO 14040 and ISO 14044. While each case study was developed independently of the others, all followed the same ISO methodology, incorporating a predefined LCIA method embedded in the LCA commercial software SimaPro.

The LCA calculations in the LCST aim to evaluate impacts that precede the use phase of food products. A comprehensive understanding of the environmental impacts of products necessitates examining and evaluating all aspects of their development, use, and disposal. The specific life cycle impact assessment method embedded in the developed LCST is described in the subsection 5.1.

3.1.3. Life cycle costing

LCC tracks and accounts for all expenses throughout a product or project's life cycle. It covers costs from suppliers, producers, consumers, and end-of-life (EoL) actors. LCC has grown from a project appraisal tool to a crucial component in environmental impact assessments, sustainability analysis, LCA, and societal assessments. Traditional LCC or cost management methods may miss end-of-life (EoL) costs or fail to consider environmental impacts in sustainability assessments [169]. Therefore, LCC should encompass the entire life cycle and extend system limits to include environmental and social factors, depending on the specific goal.

Fig. 3.3 shows the three main LCC methods: conventional (C-LCC), environmental (E-LCC), and societal (S-LCC). C-LCC typically focuses on costs borne by the primary producer or product user, often excluding EoL scenarios and other life cycle stages, thus limiting its compatibility with comprehensive environmental appraisal methodologies like LCA [170]. In

contrast, E-LCC matches LCA in terms of system boundaries and product system models, making it a complementary approach. It includes costs from the supplier chain, which C-LCC generally skips [163]. Thus, E-LCC can be used as part of a sustainability assessment, not a standalone method [171], [172].

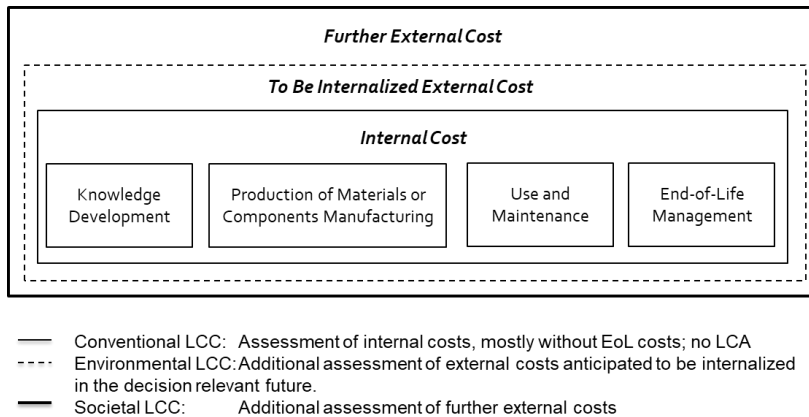

Fig. 3.3. System boundaries for different LCC approaches [170].

An E-LCC may compare life cycle costs, identify direct and indirect cost drivers, estimate product modification improvements, and discover win-win situations when paired with LCA. E-LCC uses goal and scope definition, information gathering, interpretation, hotspot detection, and sensitivity analysis, like LCA. The methodology uses quantitative and qualitative interpretations, including investment appraisal tools and nonmonetary aspects like market type and sales volume [170], [171].

Like LCA, E-LCC uses direct cost data per unit process. Complex situations or typical allocation processes may necessitate activity-based costing (ABC) for indirect costs [170]. The methodology aligns life cycle stage costs for materials, energy, and operational activities with the LCA reference flows [173], [174].

S-LCC encompasses all social actor costs associated with a product's life cycle, extending beyond E-LCC. It considers external costs and externalities, including public health and environmental impacts, making it significant for corporate social responsibility and government decision-making [169], [171], [172], [175].

LCC modeling categorizes costs by economic categories, life cycle stages, and activities. It allocates indirect costs using physical or financial parameters, notably in FW studies. To examine the costs and advantages of FW prevention and management methods, stakeholders must differentiate expenses along the supply chain [169], [170]. This comprehensive LCC approach can be used to evaluate food supply chain options for economic sustainability, reducing food waste and enhancing efficiency.

In this research, the LCC methodology plays a crucial role in evaluating the economic sustainability of food supply chains, complementing the environmental insights gained from LCA. LCC, particularly in the context of food products and FW management, presents a

complex, multi-dimensional aspect and lacks a standardized methodological framework, especially when integrated with LCA [169], [176].

The preferred approach to undertake the life cycle cost assessment in this research is the environmental one, as this assesses for almost all costs associated with the life cycle of a product that is directly covered by one or more of the actors in the product life cycle (manufacturer, supplier, transport companies, retailer), with the inclusion of externalities that are anticipated to be internalized in the decision-relevant future. This is according to the sound and broadly accepted definition in [170].

Some important aspects to consider when implementing the E-LCC in this study are:

- Cut-off criteria: environmental cut-off is to be used to avoid the evaluation of cash flows related to processes (labor, capital, etc.), as each one of those processes might be pretty different for each type of supply chain (dairy, meat, beverages, etc.). Only cash flows linked to material flows (energy, fuels, materials) are accounted for using the environmental cut-off criteria.
- The cost modeling methodology should focus on activity type or stages, evaluating the material flows considered. This will result in a cold chain cost for each product assessed within the E-LCC approach.
- Externalities such as the cost of investments and the monetary valuation of environmental impacts, using a standard economic conversion factor, can be included, especially according to the literature, under E-LCC approaches.
- According to [177], a steady-state model must be employed in an E-LCC, as most LCA applications lack temporal specification, and it is assumed all technologies remain constant over time, being input-output analysis models.
- For future scenario evaluations, considering the investments required to implement energy efficiency measures, a socio-economic key indicator, such as cost/benefit ratio or net profit, can be used to present the results.
- The main advantage of E-LCC versus the conventional one is that it is consistent for sustainability assessments of products, as some external costs are internalized within the boundaries. Furthermore, E-LCC assessment is a tool for internal decision-making and external communication, similar to LCA.
- The assessed cost categories are development (monetary valuation of investments), materials, energy, transport, and emissions.

Keeping in mind the system boundaries previously defined in the LCA, the goal of the E-LCC undertaken in the study cases under this research project, which applies to tool development, is to identify the economic impact of energy and material flows within the life cycle of food supply chains.

The LCC scope in this research aims to inform decision-making when comparing scenarios in which energy efficiency measures are either implemented or not. As shown in Figure 3.4, the system boundaries will only account for the food chain after the final product, whatever it may be, is stored in the manufacturer's warehouse.

To expand the system boundaries and facilitate a single-actor evaluation, this research also focused on implementing C-LCC, a concept that is later reflected in the developed tool. However, given the nature of C-LCC, the system boundaries under evaluation are different and mainly focused on the food processing stage, as seen in Fig. 3.4.

The intended benefit for the tool's users is to ease the process of LCC evaluation and identify the potential benefits of flow changes depending on the impacts on energy efficiency measures. As the environmental cut-off criterion is implemented, complexity related to the calculation of CAPEX and OPEX is removed, as the exclusive assessment of material and energy flows is conducted for a specified functional unit. The impact of energy efficiency measures or operational changes under different scenarios is reflected in those flows (energy, fuels, refrigerants, electricity, etc.).

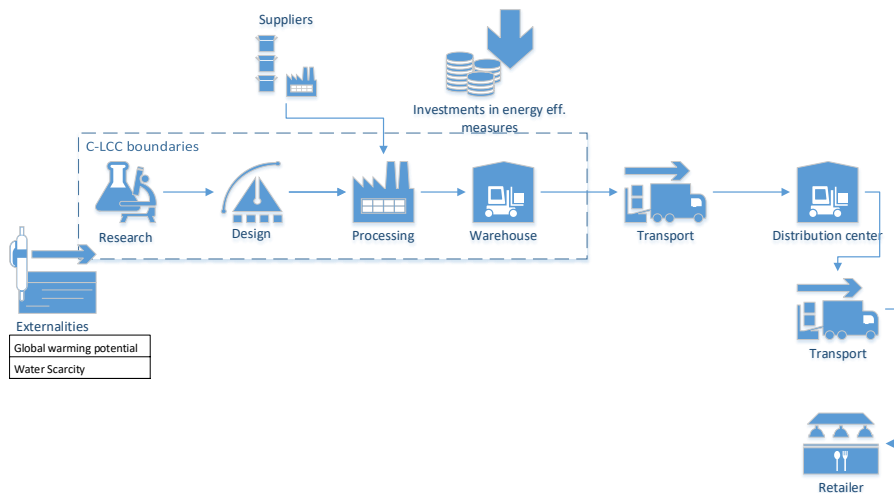

Fig. 3.4. Evaluated C-LCC system boundaries.

3.1.4. Social LCA and its challenges

The social component, which prioritizes the satisfaction of basic needs and fair access to sustainable development benefits, is a crucial pillar of sustainability. Socio-economic sustainability issues like social and economic inequality, human rights, economic exploitation, malnutrition, limited access to clean water, prevalent diseases, illiteracy, refugee crises, and gender inequality have been discussed for 40 years. The UN's SDGs and ISO 26000 guidance on social responsibility address these issues [20].

Technological advances and population growth exacerbate environmental and social issues, such as climate change and inequality, which threaten economic growth, a process that traditionally requires more materials and energy. This calls for a new development paradigm that prioritizes reduction, reuse, and sharing to create a bio-economy where human well-being is decoupled from environmental degradation and societal progress is balanced with ecosystem preservation and social equity. Researchers, industries, consumers, and politicians must collaborate to support this paradigm [178].

Social impact assessment is crucial for addressing some of sustainability's qualitative aspects and encompasses diverse stakeholder perspectives. Due to the multiplicity of stakeholders, selecting social performance metrics is challenging [178]. Social life cycle assessment (S-LCA), an extension of LCA and part of LCT, evaluates a product or service's social impacts [179] [180], [181], [182].

S-LCA evaluates the social performance of organizations in terms of product quality and stakeholder relationships. The UNEP, SETAC, and Life Cycle Initiative's S-LCA guidelines categorize stakeholders into six groups and define subcategories of impact based on social issues or traits. Indicators evaluate these subcategories using inventory data [183].

Methodological advancements and real-world experiences address standardization and enterprise-specific implementation in S-LCA development. The current S-LCA criteria include goal and scope, S-LCI, S-LCIA, and interpretation [183], [184]. It defines scenarios and functional units, identifies stakeholder social subjects, consolidates impact subcategories, and identifies essential decision-making issues [185].

Communicating social implications promotes socially responsible consumption and production. The purpose of social assessments varies among practitioners, targeting different stakeholders, including businesses, consumers, and NGOs [186]. In a corporate context, S-LCA aims to enhance socially responsible practices and competitive advantage. Strategies for sustainable development in consumption and production include innovation, choice manipulation, and choice editing [187]. Social initiatives by companies also offer community benefits like market creation, innovation, and talent retention.

For end-users, social impact assessments enable informed product choices contributing to community welfare. NGOs typically raise consumer awareness about adverse social impacts, such as child labor and hazardous working conditions [42], [180]. Collaboration among businesses, civil society, and governments has fostered international frameworks for corporate responsibility and sustainability [188].

Given the lack of a standard for undertaking impact pathways methodology and the few ones developed until now in S-LCA, the reference scale is the preferred method when engaging in S-LCA from a research perspective. However, the reference scale path is a semi-quantitative method that does not follow the same input-output approach found when transforming LCI into impact categories through a standardized LCIA method, as in LCA or LCC [183].

Implementing the reference scale path proposed in the S-LCA guidelines from the UNEP requires the use of several qualitative research tools, such as interviews, regional context-based analysis, and a multidisciplinary approach that might provide valuable nuances on the sustainability profile of a product or organization, making it challenging to incorporate into the proposed LCST in this research.

Thus, a different approach, closer to the S-LCA methodology (explained in section 5.3), was integrated into this project and reflected in the developed LCST. Under this approach, the LCA practitioner using the tool can also select whether to include the willingness to pay for externalities, such as global warming potential. Eventually, upon agreement between all partners, human health effects or ecosystem damage can also be included. This choice should

affect the life cycle cost and the environmental assessment, avoiding double-counting for determined impacts.

This approach falls under the widely accepted concept of social cost, which typically refers to the broader impacts of actions or policies on society, which can include a range of factors such as health impacts, quality of life, and economic well-being. One specific and well-discussed example in scientific literature is the social cost of carbon dioxide. The social cost of carbon dioxide measures the monetized value of the damages to society caused by an incremental metric ton of CO₂ emissions [189]. This is a critical metric in climate policy and is used in cost-benefit analysis. It has been concluded that improved models and methods have led to a significant increase in the estimated social cost of carbon dioxide, affecting the perceived benefits of greenhouse gas mitigation and climate policies [189].

3.1.5. Life cycle sustainability assessment

An LCT approach was implemented in this study, in parallel with the development of the ICCEE project, which aimed to facilitate the food and beverage sector cold chains to undertake energy efficiency measures after carrying out supply chain energy assessments.

While the ICCEE project and tool focus on the cold chains in the food sector [190] Due to its significant stages (refrigerated transport, processing, and storage) with considerable energy-saving potential, the research developed for this doctoral Thesis is suitable for any food supply chain, regardless of whether food products are subject to refrigeration during some stages in the supply chain or not. The research follows a holistic approach, shifting from a single company perspective to a chain assessment, which is believed to lead to increased opportunities for energy efficiency measures.

This research integrates the characteristics of food supply chains of the food and beverage sector in an analytical decision support tool with tailor-made analyses related to the energy performance for the different process stages (e.g., raw material preparation, logistics and warehousing operations, production and processing of products, packaging). To enable the update of energy efficiency measures and to support the decision-making processes of the supply chain companies in estimating their energy-saving potential, this research project designed and delivered a dedicated cold supply chain energy efficiency tool.

The different LCT tools utilized for the proposed methodology (environmental LCA, LCC, and S-LCA) were implemented simultaneously for each case scenario under study, following a standardized approach for each case study. A more complete description of each case study is provided in the subsection 4.1. Some of the LCT benefits believed to be delivered after implementing it and interpreting results are:

- helps to make choices considering environmental, economic & social impacts on a product's life.
- allocates responsibilities to those involved when deciding on a product's design, production, and consumption policies and procedures.
- enables product designers/ service providers, government agents, and consumers to make long-term choices considering all environmental media (air, water, land).

- companies can use results to direct products/ processes towards sustainability through ‘cleaner’ products/process options (eco-design).
- enhances company environmental/ occupational H&S, risk and quality management.
- secures governmental initiatives for strengthening the industrial and service sectors to responsibly protect the environment and society.
- guides consumers by offering better information regarding purchasing, transport systems, and energy sources, increasing public involvement with industries and governments towards sustainable development.

LCT helps comprehend the trade-offs and synergies between environmental impacts and product lifecycle stages. Industries can optimize their processes for both immediate environmental benefits and long-term sustainability by adopting this strategy. A comprehensive picture is needed to establish sustainable strategies and prevent solutions that fix one problem but create another. LCT provides a solid framework for incorporating environmental factors into decision-making at all levels as industries realize the necessity of sustainable development for long-term sustainability and social responsibility.

LCA is essential in ecodesign and manufacturing to assess environmental impacts. Recent advances in LCA integration with manufacturing systems address the ecological impacts of production equipment, technical services, and energy supply. To facilitate product development decisions, the life cycle sustainability assessment (LCSA) framework helps identify sustainability hotspots in manufacturing goods and processes [191], [192], [193].

The LCA evolution shows the method's versatility in addressing industrial process environmental impacts [194]. In the pharmaceutical industry for example, LCA has become the preferred application in assessing the global warming potential and other environmental impacts of chemical processes, thereby guiding more sustainable practices in pharmaceutical production [195].

LCA is also essential for sustainable building design and demolition in the construction industry. It evaluates the environmental impacts of construction and demolition materials to promote sustainable waste management and environmental protection. The sustainability impacts of civil infrastructures are evaluated using LCA methods to reduce the sector's excessive resource consumption and greenhouse gas emissions [196], [197], [198], [199], [200].

Considering the findings summarized in the subsection 2.5 “Research gaps” and tested in [96], a sustainability assessment method based on life cycle thinking tools is proposed in this study, in accordance with the hypothesis and main objectives of this thesis, and following the aforementioned research methodology.

The focus in the quest for sustainability extends beyond merely reducing carbon emissions and encompasses a multifaceted approach, considering ecological, social, and economic pillars while being vigilant against unintended consequences.

Importantly, those in poorer nations often bear the brunt of these unintended consequences, with limited means to effect change or voice their concerns. Thus, a comprehensive approach

that weighs societal, environmental, and economic impacts under a fair approach is crucial for a sustainable future [201], [202].

Positive knock-on effects also emerge from holistic solutions. Addressing issues like overconsumption curbs greenhouse gas emissions and pollution, and eases resource strain [203], [204]. Supporting local businesses reduces transport emissions and strengthens communities, while enhancing education empowers individuals to make informed choices that positively affect their surroundings, including reducing their carbon footprint [61], [205].

Furthermore, ecosystem regeneration through practices like rewilding, reintroducing native species, and predator control boosts biodiversity, benefits adjacent ecosystems, and acts as an efficient carbon sink [206], [207]. Addressing single issues such as carbon emissions is a commendable starting point. However, adopting a holistic perspective and contemplating the broader implications of actions is essential for reaching a sustainable state between humans and the ecosphere [208].

Although there is no unified and accepted framework for LCSA, as the approach and KPIs -or impact categories- vary depending on the study assessed, a general overview of the main impact indicators is presented in Fig. 3.5. The mind map is developed based on the typical environmental impact mid-point categories found in most LCIA methods, the LCC indicators [170], and the social LCA impact indicators presented in the UN guidelines for S-LCA [183], [209].

LCSA helps decision-makers transition to more sustainable systems in the energy sector by highlighting challenges, methodological approaches, and sustainability indicators [210].

Food LCA studies span upstream (agricultural, livestock, fisheries, aquaculture, and packaging production) and downstream (distribution, consumption, and waste management) processes [17]. In recent years, the food industry has used LCT to assess and reduce environmental and social impacts. The rise of nutritional life cycle assessment (n-LCA) shows a trend to incorporate nutritional factors into classic LCA frameworks, making food industry environmental impact evaluations more thorough [211].

Food supply chains significantly contribute to environmental impacts, and food and drink goods account for a substantial share of the ecological impacts of private consumption. Harmonized measurement systems are needed to apply circular economy principles to the agri-food sector. A life cycle approach to environmental evaluation covers the entire chain, enabling more effective mitigation options [212]. Due to the complexity of the agri-food chain and the requirement for integrated assessment tools, a lifecycle-based dashboard has been proposed to organize and test cross-sectoral applications [213].

The development of environmental assessment in the agri-food sector dates back to the 1970s, with an initial focus on primary energy demand. Over the years, LCA studies in food production and consumption have proliferated, with a substantial increase in publications and research focus, highlighting the evolving nature of LCA applications in this sector [214].

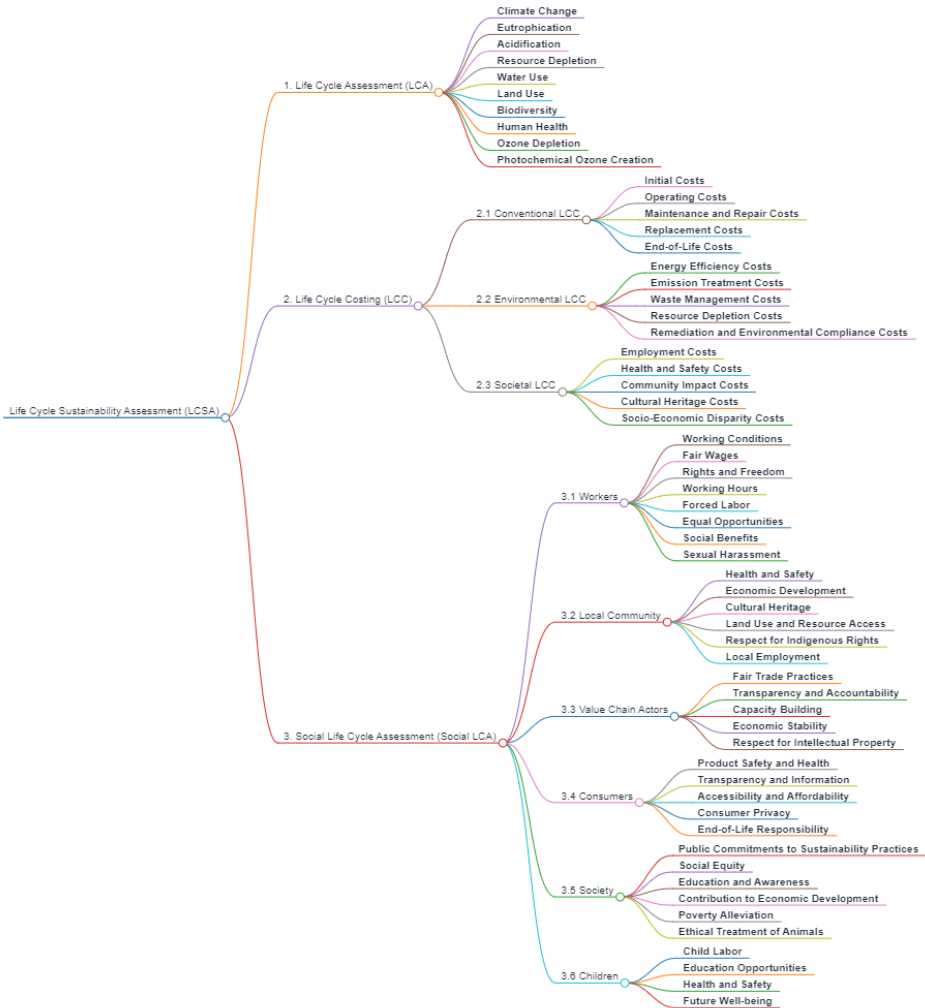

Fig. 3.5. Life cycle sustainability assessment KPIs.

The adoption of life cycle thinking in these industries reflects a growing awareness of the need for comprehensive environmental impact assessments. LCT approaches enable industries to develop, innovate, and make informed decisions that align with global sustainability goals. LCT must evolve and be applied across sectors to achieve global environmental sustainability.

An in-depth examination of the methodologies employed, as outlined in the content analysis conducted during the literature review section, suggests the need for a more comprehensive LCSA framework to accurately reflect the methodology's iterative nature. Therefore, the proposed framework enables the development of various research objectives across the different topicalities and activities of this work. The framework is presented in Fig. 3.6.

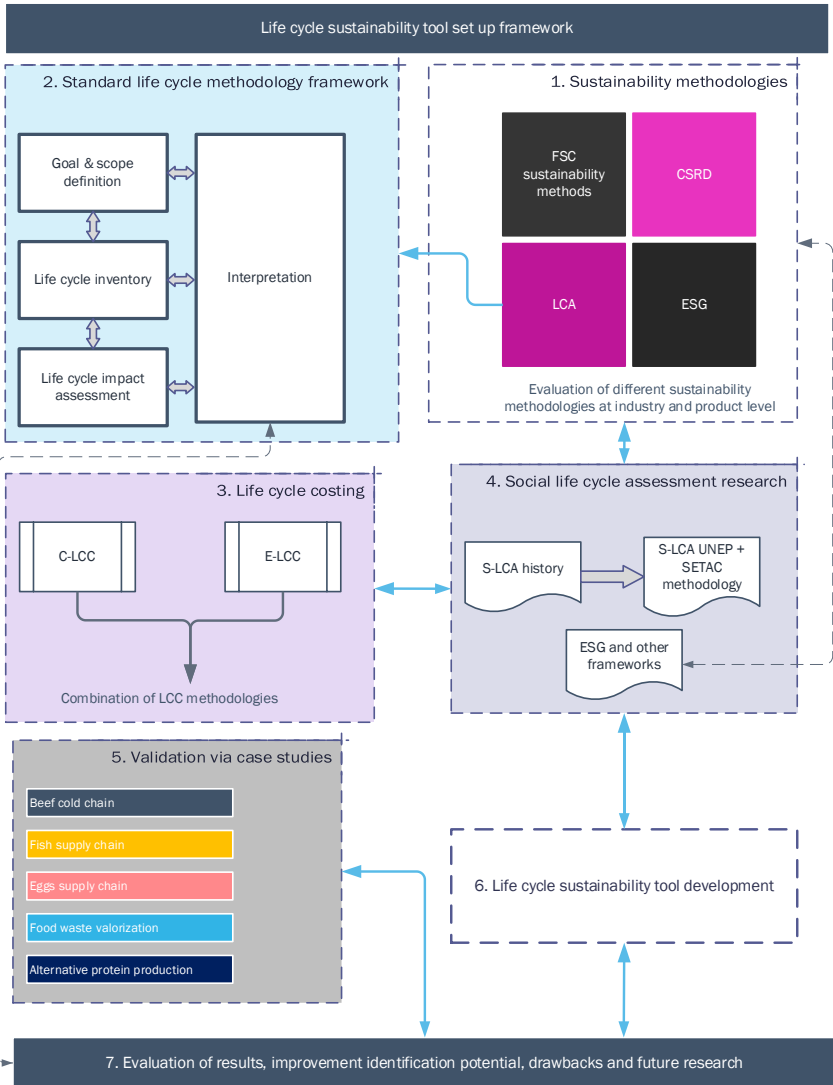

Fig. 3.6. Integrated research methodology into a life cycle sustainability framework.

4. RESULTS AND DISCUSSION

The methodological approach was tested in several micro case studies, mainly in a European context, thanks to the development of the ICCEE project [215]. To achieve these objectives, a thorough analysis of the supply chain energy performance (and the parameters influencing it) was needed to understand where the energy consumption comes from and how to reduce it at the different stages of the food and beverages supply chain. Food production processes rely on multiple inputs of raw materials that are processed in several steps throughout the supply chain.

It is worth noticing that the impact assessment methods for LCA or LCC types were not always the same in all case studies. This was done to test different methods and evaluate the advantages and shortcomings of each one of them. The learnings from this process were later considered in defining the LCST framework implemented in this research.

4.1. Case studies description and main results

Four case scenarios were developed and tested during the research and development of a sustainability framework, some represented in published scientific papers and others during the supervision of the master's thesis. A brief description of the goal and scope, functional unit, system boundaries, and central aspects of the life cycle inventory for these case studies is presented in the following sub-sections.

4.1.1. Beef supply chain

This study aims to evaluate the environmental impacts of a regional and local beef cold chain in a European context. The beef cold chain is complex and involves several factors and an undefined number of stages, including slaughtering, processing, storage, and transportation activities across different geographical areas.

In this case study, the performance of four scenarios (including the baseline) is compared and analyzed, namely (the scenarios are described in detail in Article # 1):

- baseline scenario;
- energy recovery scenario through the transformation of biowaste into biogas with subsequent cogeneration of heat and power (CHP) (EEM-1);
- renewable energy use integrating photovoltaic solar energy (EEM-2);
- efficient compressor replacement (EEM-3).

The supply chains under study were modeled without considering the end consumer step as that stage can be very flexible and unpredictable, in fact, depending on the type of consumers, their needs, living conditions, energy consumption, geographical area, social conditions, political, economic, and environmental constraints, and finally, the type of end consumer (e.g., household, restaurant, hotel, canteen, etc.).

The processing stage for the regional beef cold chain involves a larger, more articulated, and highly diversified production process that accommodates a greater variety of products than the local one's processing stage. In both scenarios, the processing phase also includes the post-processing storage of the beef. Transportation was considered from the farm to the

slaughterhouse, from the slaughterhouse to processing, from processing to a central distributor, and from the major distributor to wholesale and retail (see Fig. 4.1).

Additionally, two types of supply chains were modeled: local and regional. The main differences considered between regional and local supply chains are product demands during the processing and storage phases, transport distances, especially from the processing and storage phases to the distribution center, and the geographical context in which the two (i.e., local and regional) supply chains operate.

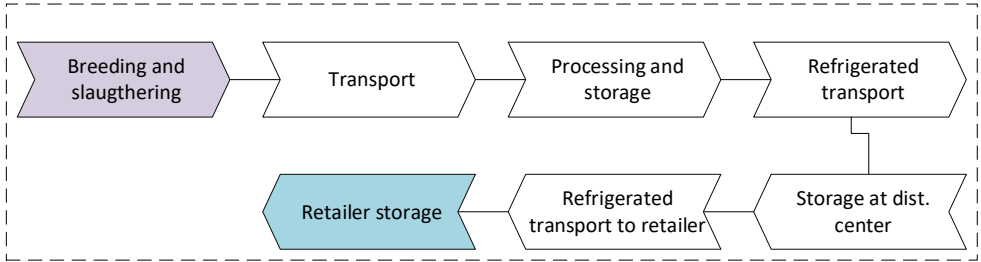

Fig. 4.1. Beef supply chain.

In this study, the functional unit (FU) is represented by 1 kg of beef delivered to the wholesaler or retailer, so all reported values (such as energy consumption, packaging, waste, water, and transport) across the life cycle have been normalized to 1 kg of product.

This study obtained data from two different processing companies in Italy that are conducting activities such as cutting, freezing, and packaging beef. For insights into the entire inventory description¹. The LCI is described in Tables 4.1 to 4.3.

Table 4.1. LCI for the processing stage in the beef supply chain

Material	Regional	Local
Output - frozen meat (beef), kg	1.0	1.0
Output - meat organic waste, kg	0.66	0.66
Input - raw meat, kg	1.66	1.66
Thermal energy, MJ	2.391	2.391
Electricity, kWh	0.14742	0.12346
Tap water, kg	0.013	0.0042
Packaging material - polyethylene, low density, granulate, kg	0.000056	0.000066
Packaging film, low density polyethylene, kg	0.0046	0.00583
Occupation industrial area, m ²	0.000221833	0.00031

¹ Article 1: Effects of Energy Efficiency Measures in the Beef

Table 4.2. LCI for storage at the dist. center in the beef supply chain

Material	Regional	Local
Output – frozen meat, kg	1.0	1.0
Input – frozen meat, kg	1.0	1.0
Electricity, kWh	0.01957	0.01957
Tap water, kg	0.034463	0.0282
Occupation industrial area, m ²	0.000002712	0.000002712

A distinction between regional and local supply chains is made as follows: the regional cold chain begins with the breeding in Villareal (Spain), moving to the slaughter in Tarragona (Spain) with a transport distance of 200 km, and then arrives in Lleida (Spain), for the meat processing and storage phase (100 km of distance); from Lleida, the beef is transported to Italy to reach the distribution center located in Florence with a distance of 1240 km, and finally, within Florence, the meat is transported to the city's supermarkets with a further transport of 20 km.

The local beef cold chain begins with breeding in Tolmezzo (Italy) and moves to slaughter in Castelfranco Veneto (Italy) with a transport of 200 km. Then, the raw beef is transported to Verona (Italy) for processing (100 km). From Verona, the beef products are transported to the Rome distribution center (Italy) for 500 km. Finally, in Rome, food products are distributed in the city supermarkets and transported over 20 km.

Table 4.3. LCI for storage at the retailer for beef supply chain

Material	Regional	Local
Output – frozen meat (beef), kg	1.0	1.0
Input – frozen meat, kg	1.0	1.0
Electricity, kWh	0.04	0.04
Occupation industrial area, m ²	0.000042462	0.000042462

Main findings. A total environmental impact of 140 mPt was found for the regional supply chain scenario. The most relevant stages are transported from the processing facility to the distribution center, followed by the processing phase (see Fig. 4.2).

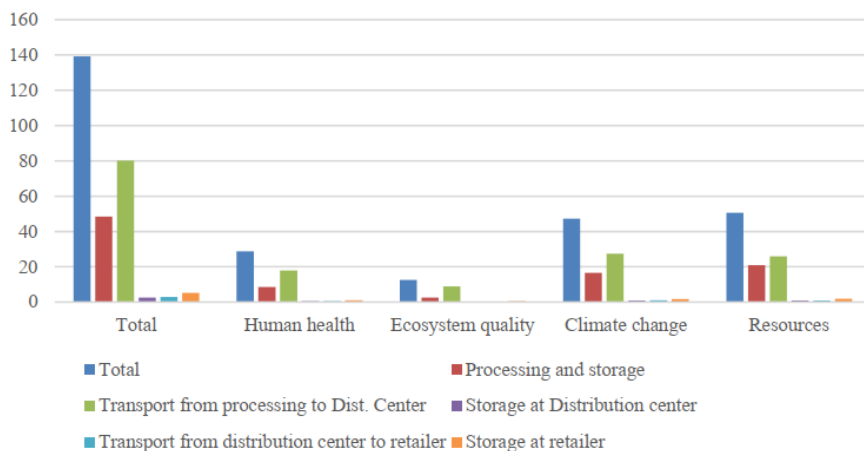

Fig. 4.2. Weighted results in a regional supply chain.

When looking at the areas of concern, the environmental burden is mainly on climate change and resource consumption and slightly less on human health, leaving the ecosystem quality only mildly affected. The results of the local beef supply chain are similar since most activities require similar energy consumption and are performed very similarly. Nevertheless, the shorter distance for transport activities, especially for reaching the distribution center after processing, makes this supply chain less environmentally intense, with a total score of 90 mPt (see Fig. 4.3).

During the study, it was identified that the EEM-1 is the one that brings environmental benefits in every single area of concern. At the same time, the other EEM scenarios barely show any difference when compared with the baseline. The EEM-1 scenario might also potentially deliver environmental credits to the ecosystem quality area due to avoiding electricity consumption from the country mix, mainly linked to fossil fuels and land use for hydropower production [216].

Since the local supply chain has a lower impact due to lower transportation distances, the savings created by the EEM-1 scenario significantly impact its overall result, showing even a negative value (environmental benefit) for the entire food supply chain. As for the regional supply chain, the local scene is unaffected by implementing the EEMs 2 and 3.

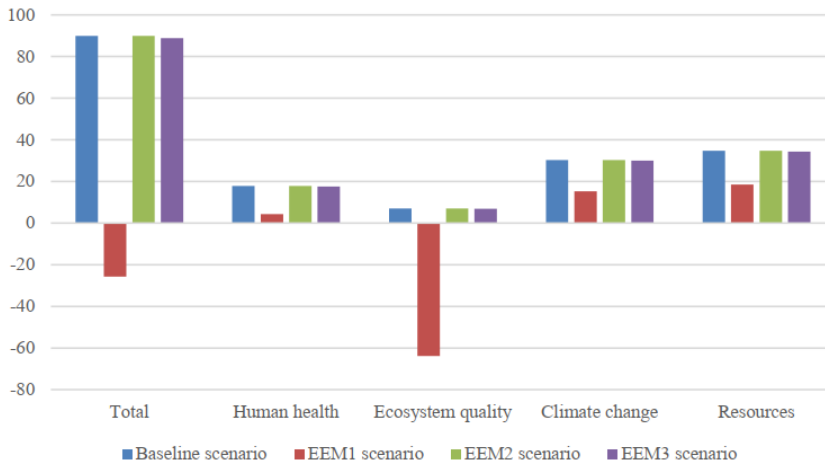

Fig. 4.3. Weighted results across different EEMs in the local supply chain.

This case study also performed an LCC, comparing the different EEM alternatives. After a sensitivity analysis, it was found that the changes in market prices for beef could either positively or negatively affect the internal rate of return or the profit index of the evaluated projects if the plants' production capacity remains constant in time. Net Present Value (NPV) analysis shows that the EEM-1 is the most attractive one from an economic perspective. Additional insights into results can be seen in Article #1.

4.1.2. Fish supply chain

This case scenario was developed for the Baltic region context, considering that Latvia receives financial support from the EU funds and other financial instruments to implement the Common Fisheries Policy (CFP) [217], [218] mainly targeting priorities set by the EU, but adapted to each member state sector [219]. By 2019, the fish production in Latvia accounted for 110200 tons of live weight, while the aquaculture sub-sector was responsible for 626.4 tons of fish and crustaceans [220].

Despite the fish sector's significant relevance in the Latvian economy, the environmental impact related to its supply chain has yet to be thoroughly evaluated, and the field remains largely unexplored. Therefore, the proposed case study aimed to provide a method for performing environmental and economic evaluations of FSC. The proposed approach is based on implementing a life cycle thinking approach, evaluating a baseline scenario for chilled Latvian cod, and exploring the implementation of two specific energy measures along the entire cold supply chain.

The proposed business-as-usual/baseline scenario for the fish FSC within the Latvian context assumed Codfish as a resource further exported to other countries in the European Economic Area. A representation of the system boundaries for this case scenario can be seen in Fig. 4.4. A literature review supported the definition of the hypothetical baseline scenario, primarily based on LCA studies of fish products within the European context [221], [222], [223].

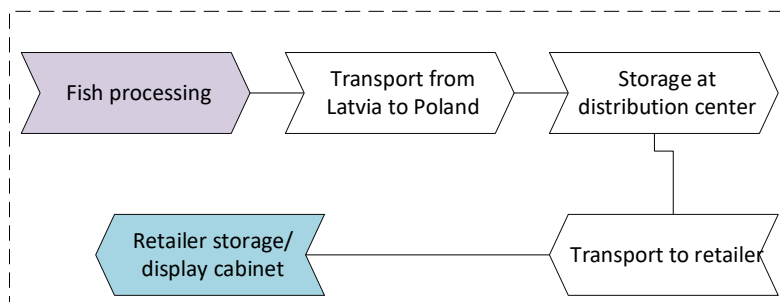

Fig. 4.4. Fish supply chain system boundaries.

For the FSC under evaluation, the port of arrival for fishing vessels has been assumed to be Ventspils, as it is one of Latvia's most prominent and well-known ports for its traditional fishing activities. Furthermore, it was assumed that all the processing required to develop a final filleted codfish is undertaken in Ventspils by a local processor, and no waste occurs downstream in the supply chain.

The environmental condition for transporting the fish is $-2\text{ }^{\circ}\text{C}$ when assuming a superchilled cooling technology and $+2\text{ }^{\circ}\text{C}$ for chilled conditions. Diesel consumption for the auxiliary unit is calculated at 3.68 kg/h . The refrigerant is R-134a, with an annual precharge of 6.5 kg and a leakage rate of 10% per year. SimaPro software® is used to simulate the model, creating the foreground system and taking the background processes from the Ecoinvent database 3.6 (Wernet et al., 2016). A summary of the LCI collected for this case study is presented in Table 4.4. Additional insights in the case study are provided in Article #3.

The life cycle cost section was developed using a C-LCC assessment to evaluate two different EMMs in comparison to the baseline scenario. The proposed energy efficiency measures are based on principles of circular economy and industrial symbiosis: anaerobic digestion (AD) in tandem with a heat and power cogeneration plant for the first scenario (EEM-1), and the second scenario, a photovoltaic plant installed at the retailer facility with the capability to supply 20% of the electricity consumption is modeled (EEM-2).

Table 4.4. LCI for the processing stage in the fish supply chain

Process	Processing		
Material	Value	Unit	
	Inflows:		
Whole-Fish-(cod)	1.74	kg	
Packaging material-(EPS)	0.0264	kg	
Electricity for CBC	72	kJ	
Electricity for storage	1.2	kJ	
	Outputs:		
Fish waste	0.74	kg	
Fish fillet product	1.0264	kg	

Main results. The IMPACT 2002+ method was used to perform the environmental profile of the proposed model [163]. This method has the advantage of delivering results both at mid-point impact categories - as recommended by the ISO Standards 14044 - and at end-point

categories (damage categories), which are an indicator of quality changes in the environment [163].

LCA results at the midpoint categories are presented in Table 4.5 disaggregated by unit processes in the considered supply chain.

Table 4.5. Mid-point category results for the baseline scenario.

Impact category	Unit	Processing	Transport to distr. center	Distribution center	Transport to retailer	Retailer
Carcinogens	kg C ₂ H ₃ Cl eq	4.8E-03	8.6E-04	1.4E-06	1.8E-04	1.8E-03
Non-carcinogens	kg C ₂ H ₃ Cl eq	3.2E-03	3.1E-03	1.7E-06	6.4E-04	2.3E-03
Respiratory inorganics	kg PM2.5 eq	1.5E-04	1.4E-04	1.3E-07	2.9E-05	1.8E-04
Ionizing radiation	Bq C-14 eq	0.91	1.17	0.00	0.24	2.66
Ozone layer depletion	kg CFC-11 eq	9.9E-09	2.7E-08	2.4E-11	5.6E-09	3.3E-08
Respiratory organics	kg C ₂ H ₄ eq	1.1E-04	7.3E-05	4.2E-08	1.5E-05	5.7E-05
Aquatic ecotoxicity	kg TEG water	14.33	15.75	0.02	3.23	23.41
Terrestrial ecotoxicity	kg TEG soil	3.86	11.54	0.00	2.36	5.51
Terrestrial acid/nutri	kg SO ₂ eq	2.3E-03	3.1E-03	2.9E-06	6.4E-04	4.0E-03
Land occupation	m ² org.arable	1.6E-02	1.7E-02	3.5E-05	3.4E-03	4.8E-02
Aquatic acidification	kg SO ₂ eq	6.8E-04	5.8E-04	8.4E-07	1.2E-04	1.1E-03
Aquatic eutrophication	kg PO ₄ P-lim	2.1E-05	1.4E-05	1.2E-08	2.8E-06	1.7E-05
Global warming	kg CO ₂ eq	0.17	0.15	0.00	0.03	0.21
Non-renewable energy	MJ primary	3.90	2.38	0.00	0.49	3.60
Mineral extraction	MJ surplus	4.7E-03	1.6E-03	1.1E-06	3.3E-04	1.4E-03

Fig. 4.5 presents the results at the endpoint category level while Fig. 4.6 presents the environmental burden distribution network. The identified hotspots are the storage at the supermarket/retailer, the processing stage, and transport under super-chilled conditions, especially in terms of resource use, human health, and climate change. The sub-activities or flows with the leading environmental burden within these processes are the electricity consumption at the retailer, the transport to the distribution center, the slaughterhouse waste treatment, and the use of the chosen packaging material for the fish fillets at the processing stage (see Fig. 4.5). Compared with other stages, the low impact delivered by the transport to the retailer (also known as food miles) aligns with the discussion summarized in the study by Coley et al. (2013) [224].

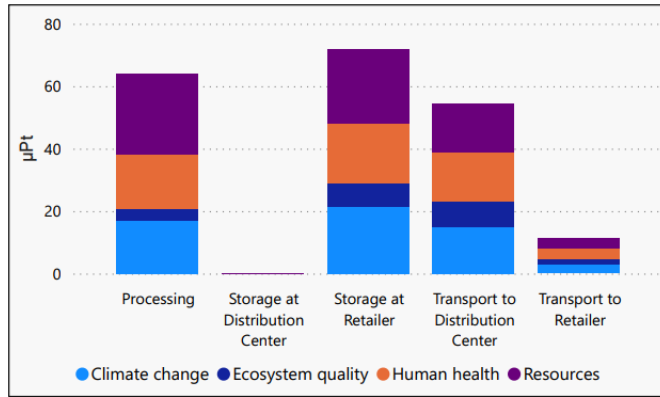

Fig. 4.5. Single score results for the baseline scenario

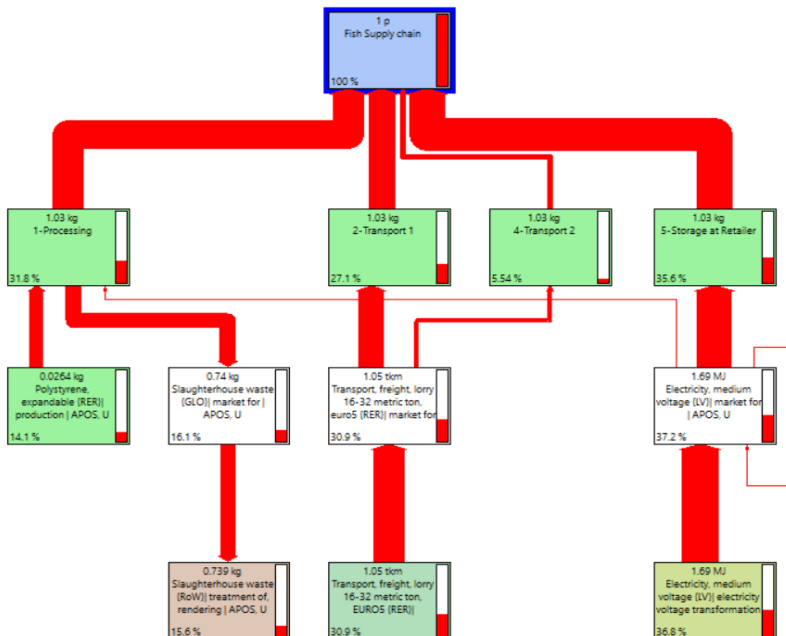

Fig. 4.6. Network visualization results.

From an overall environmental perspective, waste valorization from the processing stage could represent an opportunity to decrease the total burden of the cold supply chain. Implementing renewable energy technologies will undoubtedly provide benefits and intervention in electricity consumption at the supermarket stage. These aspects focus on the alternative scenarios defined as EEM-1 and EEM-2, respectively:

- energy recovery from biowaste (EEM-1)
- electricity production from a PV system (EEM-2)

In Fig. 4.7, the single-score results for all three evaluated scenarios are presented and compared. The baseline scenario is the one with the highest impact, followed by the scenario

where the EEM-2 is implemented, and finally, the commissioning of the EEM-1 is the one with the highest potential to reduce the total environmental impact delivered by the fish supply chain in the context evaluated. While the EEM-2 would result in a total saving of μPt (6.8 %), the EEM-1 could potentially reduce the impacts by $69.2 \mu\text{Pt}$ (34.3 %) in this FSC.

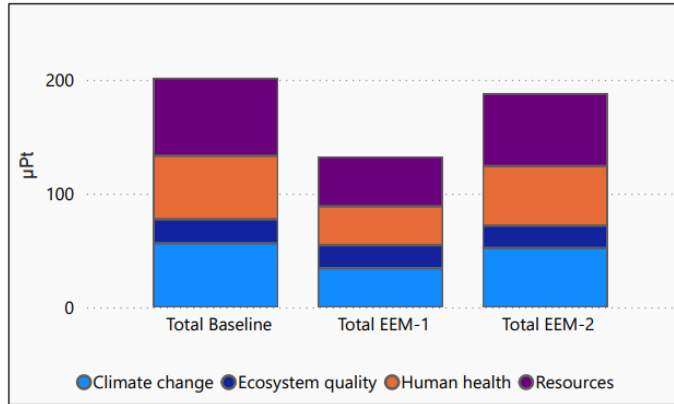

Fig. 4.7. Single score comparison results for the three supply chain scenarios.

A sensitivity analysis was conducted to assess the impact of independent input parameters on the main output parameter, expressed as a single score result. The two independent variables are the transport distance from the processing plant to the central warehouse and the energy consumption at the processor unit process. These variables were chosen considering the impact they both have on the overall baseline scenario, with transport to the distribution center being responsible for more than 25% of the total impact. In comparison, the energy consumption at the processor stage has not been displayed under the cut-off criteria of 5 %. Hence, this sensitivity analysis also works as a consistency check.

The scenarios considered for the sensitivity analysis are the decrease and increase of 5, 15, 30, and 50 percent in each selected variable. The highest and lowest single score is obtained when the transport distance increases and decreases by 50 %. The relative change in the output is calculated as follows:

$$C_r = \frac{(s_0 - s_1)}{s_0} \quad (\text{Equation 1})$$

where:

C_r = Relative change.

s_0 = model score at the baseline scenario.

s_1 = model score under the new scenario.

These changes are presented in Fig. 4.8. The relative change in single score results is shallow when the energy consumption at the processor is considered; despite changes of up to 50%, less than 1% of the change in the total output occurs. On the contrary, the modeled FSC is sensitive to fluctuations in the transport distance, with changes of up to 15 % in the total output when this influencing factor increases or decreases by 50 %.

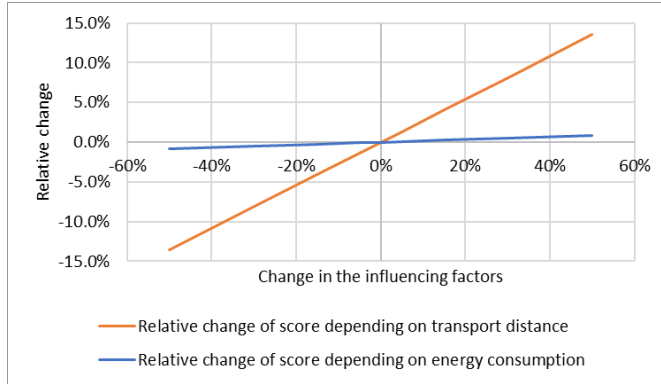

Fig. 4.8. Relative output changes depending on influencing factors.

A C-LCC evaluation compared the baseline scenario with the two proposed EEMs utilizing three economic indicators. Due to the lack of costs, primary data, also known as cost categories 3 or 4, and budget costs (secondary data) were used as input to perform the review. (for more details on the assumed budget costs, see Article # 3). A comparison of results for all three economic indicators is presented in Table 4.6. Although both options show economic feasibility potential, especially looking at the NPV indicator, the EEM-1 would be the most attractive option for an investor. The internal rate of return (IRR) and profit index (PI) also support the previous statement.

Table 4.6. Economic indicators comparison in fish supply chain.

Economic indicator	EEM-1	EEM-2
NPV	€ 520,786	€ 65,601
IRR	14.38 %	9.92 %
PI	1.95	1.25

The results from this case scenario show how end-point categories score using LCA and the evaluation of economic indicators using a C-LCC assessment can be helpful for supply chain managers and single actors in the food supply chain. However, more studies evaluating relevant FSC and state-of-the-art cooling technologies are necessary to better understand the potential for energy efficiency measures.

4.1.3. Eggs supply chain

Given that Latvia is a significant producer of eggs and egg products in Northern Europe and that no studies have been conducted to investigate the potential environmental impacts that such a substantial industry can create at the local level, a case study on eggs produced in Latvia and subsequently transported to European nations was performed [225]².

The case scenario was developed under specific product category rules (PCR), a methodological framework for developing EPDs. This document provides a standard approach

² This research and Master thesis were co-supervised by the author of this doctoral thesis as part of his doctoral research.

for assessing the environmental performance of hens' eggs or other birds in shells and fresh [226].

This study aimed to evaluate the activities involved in the supply chain of egg products, including the transportation of chickens to the company, production, packaging, and the value chain, all the way down to the distribution centers. However, the transportation from the supermarket to the household, household use, and waste disposal are beyond the scope of the work.

According to the specific followed PCR, the declared unit shall be defined as 1 kg of product, as presented to the consumer [226]. The weight of the packaging is not included in the definition of DU. The selected DU in this case study is 1 kg of eggs of type No. 3 + 1 kg of eggs of type No. 2 + 1 kg of type No. 1 (where 1 kg of eggs corresponds to ~17 eggs, including packaging material) at the retailer's point. All the upstream unit processes in the modeled supply chain were subject to mass and energy balances, considering the potential waste generation at each FSC stage.

The product's life cycle, as in the PCR, is divided into three stages for different data quality requirements and the display of results: upstream processes (from the cradle to the gate), core processes (from the gate to the cradle), and downstream procedures (from the gate to the grave). Nevertheless, to maintain a similar approach to the other case studies, the system boundary line has been drawn at the distribution center, avowing transport of eggs to households and the use phase. The environmental performance associated with the three life-cycle stages mentioned above must be reported separately and aggregated in the EPD. According to the PCR, a cut-off rule of 1 % shall be applied.

The assessment adopts a cradle-to-gate approach with options (according to the PCR denomination), encompassing all stages of the egg supply chain until they are ready for transportation and transportation to distribution centers (see Fig. 4.9). Geographically, the scope of the study is limited to the European Economic Area, as this is where the main egg products are exported. The temporal boundaries of the study do not account for any future technologies.

By dividing the system boundaries into upstream, core, and downstream activities, it is possible to identify and prioritize the life cycle stages with the most significant environmental impact and focus efforts on reducing these impacts.

Regarding the LCI, the company under study provided all inventory data under its operational and financial control (primary activity data) for the three types of eggs it produces. No.3 cage-laid hen eggs, No.2 barn-laid hen eggs where hens can roam inside barns, and No.1 free-range eggs with hens having access to barns and open-air outside, with a minimum requirement of 4 m² of outside land per hen.

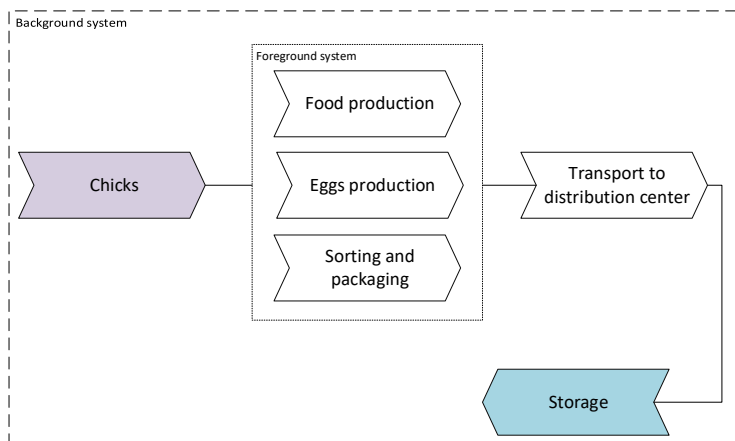

Fig. 4.9. Eggs supply chain system boundaries.

The inventory data includes 1-day-old chicken purchases and deliveries from Germany, and operational information about the company's five locations - Bene, Jelgava, Iecava, Madona, and Daugavpils - such as yearly consumption of processed grains for food, 1-day-old chicken incubation process, water and feed for hens, energy used during sorting and packaging of eggs, as well as wastewater and manure management.

A cut-off criterion was applied for lost chickens during transportation from Germany, eggs lost in the hen house, and the losses associated with packaging, which were all less than 1% in mass for each of their relevant processes. A summary of the LCI collected for this case study is provided in Table 4.7 to Table 4.9.

Table 4.7. LCI of materials per egg type.

Inputs	Weight	Eggs No.3	Eggs No.2	Eggs No.1
Wheat	kg	1.19	1.33	1.55
Sunflower slits	kg	0.31	0.35	0.40
Barley	kg	0.29	0.32	0.37
Corn	kg	0.24	0.27	0.31
Calcium	kg	0.24	0.27	0.31
Soy	kg	0.12	0.13	0.15
Plastic boxes	kg	0.01	0.01	0.01
Paperboard boxes	kg	0.07	0.07	0.07
Transport of plastic boxes (1350 km)	kg*km	7.7	7.7	7.7
Transport of paperboard (1414 km)	kg*km	99.0	99.0	99.0

Table 4.8. Core process LCI.

Inputs	Units	Eggs No. 3	Eggs No. 2	Eggs No. 1
Food processing				
Water	m ³	3.69E-05	3.687E-05	3.67E-05
Electricity	MWh	1.64E-05	1.922E-05	1.96E-05
Natural Gas	MWh	1.03E-05	1.033E-05	1.03E-05
Egg production				
Electricity	MWh	1.29E-04	9.972E-05	2.10E-04
Natural gas	MWh	1.23E-04	7.364E-05	5.13E-05
Water	m ³	4.09E-03	3.21E-03	3.85E-03
Diesel (internal) Euro4 vehicle	l	1.40E-03	1.40E-03	1.39E-03
Egg sorting and packaging				
Electricity	kWh	2.19E-02	2.19E-02	2.19E-02
Natural gas	kWh	1.48E-02	1.48E-02	1.48E-02
Wastewater treatment				
Wastewater treatment	liters	6.70E-02	6.70E-02	6.70E-02

Table 4.9. Downstream process LCI.

Inputs	Units	Eggs No. 3	Eggs No. 2	Eggs No. 1
Transport to distribution center				
Egg transport Latvia	50 km (25 %)	12.5 kg/km	12.5 kg/km	12.5 kg/km
Egg transport LT.EE	300 km (25 %)	75 kg/km	75 kg/km	75 kg/km
Egg transport EU	1500 km (50 %)	750 kg/km	750 kg/km	750 kg/km
Manure (avoided emissions)				
Manure	l	1.55E+00	1.55E+00	1.55E+00
Land use				
Land use	ha	0	0	2.68E-05

Main Results. The impact assessment for all three egg types is presented in endpoint categories based on the Recipe 2016 impact assessment method. The results of the end-point impact categories reveal that the highest impact comes from upstream activities, as shown in Fig. 4.10. Overall, the findings indicate substantial disparities in the influence of the three egg varieties on human well-being, ecological balance, and resource accessibility. Egg No.1 exhibits the least detrimental effects on human health and the ecosystem, whereas egg No.3 demonstrates the most significant impact. Eggs No.1 exert the most important influence on the availability of resources, while eggs No.3 has the most negligible impact. Eggs No.2 has a moderate effect on all three categories.

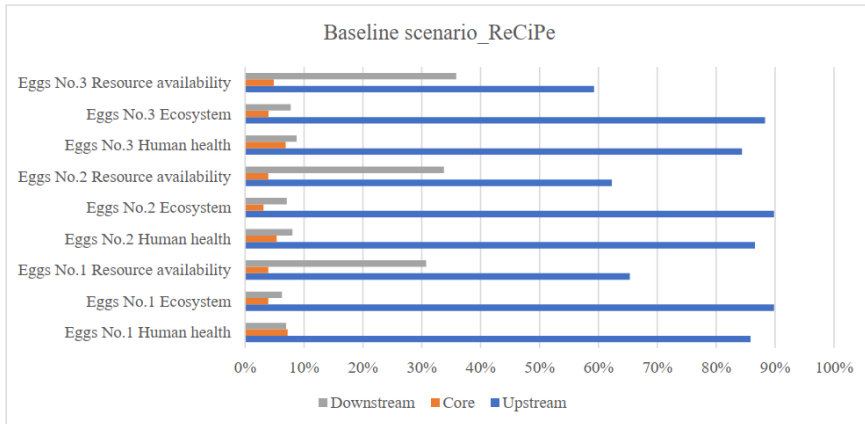

Fig.

4.10. LCA results at endpoint categories for the three types of eggs.

Regarding climate change impact, eggs No.1 had a total impact of 3.58E+00 kg CO₂eq/kg eggs, while eggs No.2 and eggs No.3 had a total impact of 2.94E+00 kg CO₂eq/kg eggs and 2.79E+00 kg CO₂eq/kg eggs, respectively (see Fig. 4.11). This is explained by an inventory analysis, which reveals that hens laying eggs No. 1 require a greater amount of food, which can be attributed to the wastage of feed in the free-range system and the hens' higher calorific needs. The most significant influence on all types of eggs is derived from earlier actions in the production process, although the impacts may vary for other activities.

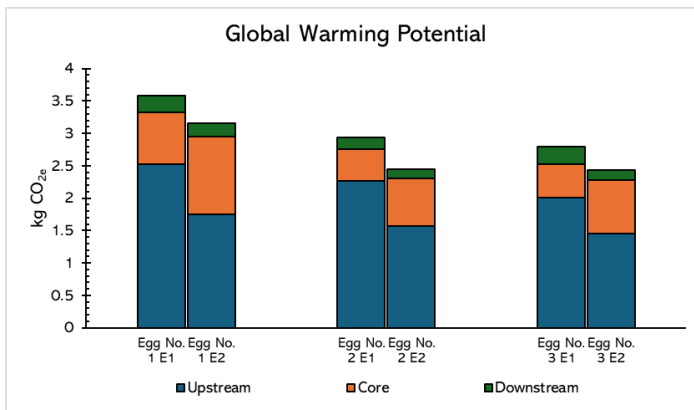

Fig. 4.11. Comparisons of results in the climate change area of concern.

4.1.4. Sustainability evaluation of food waste valorization

This case study focuses on other features related to the sustainability of food products and the food industry, especially those processes at the end-of-life stage. The case study focuses on specific waste treatment scenarios for food waste that could enhance the sustainability profile of food products throughout their life cycle. This case study aimed to evaluate the environmental impacts of potentially commissioning an energy recovery plant for the Mondonedo landfill facilities in Colombia. The selection of this particular landfill is an opportunity to utilize primary data from an existing and ongoing expansion project.

The current operation, which includes methane collection, a burning system, and a future power generation system in the Mondonedo landfill, could reduce GHG emissions from its overall operation. However, the environmental and social performance has not been fully evaluated, nor has the potential for a complete energy recovery system through biochemical and thermochemical processes been explored. For this reason, this work is undertaken to develop a model for implementing an AD plant for biogas production, methane upgrading, and energy recovery in this landfill. The results encompass the three sustainability dimensions, as evaluated using LCA, LCC, and S-LCA indicators.

The scope of this evaluation begins by defining the functional unit (FU), which is 36500 t/year of food waste processed, understood as 100 t/day for landfill sites' managerial purposes. The scope of this study does not include the activities related to sorting and recovering organic material. It corresponds to a gate-to-gate approach comprehending AD, biogas production, purification, and upgrading to biomethane, and thermal and electrical generation by cogeneration of heat and power (CHP). The system boundaries of the study can be seen in Fig. 4.12. An attributional system model is used for this study.

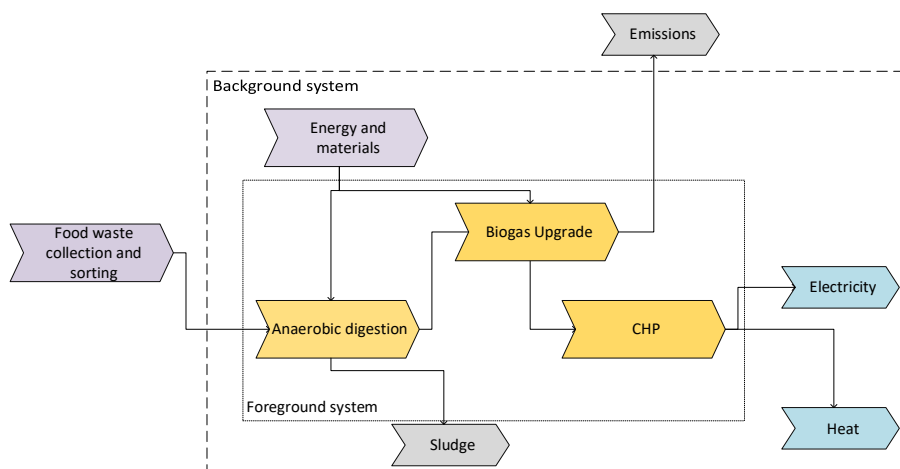

Fig. 4.12. System boundaries for FW valorization case.

The LCI includes material and energy flows, as well as the equipment and infrastructure required for production. The primary data regarding total waste, food waste composition in the waste, and degradable organic content (DOC) has been retrieved from the report for reductions

of emission project of the Mondonedo landfill considering average values for 2007–2016 [227]. For the biogas conversion, biogas upgrade to biomethane, and CHP plants operation, a process model was built in *SuperPro Designer*[®] to conduct mass and energy balances of all products and elementary flows (see Fig. 4.13).

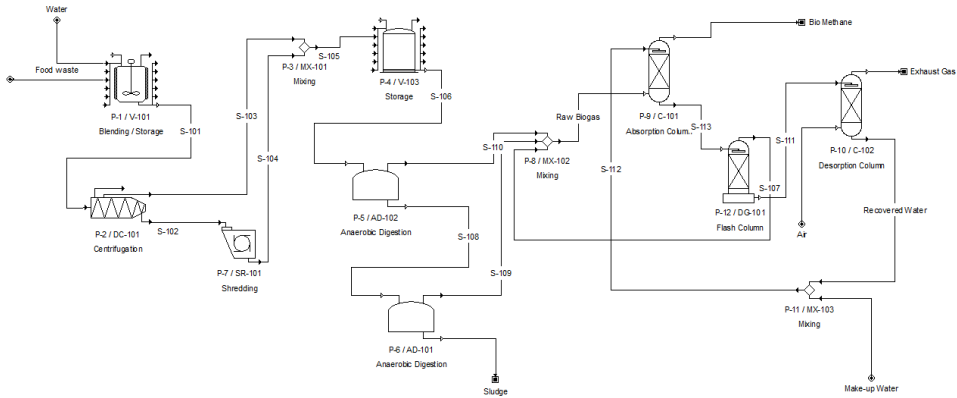

Fig. 4.13. Flow diagram for proposed technologies.

Some of the primary considerations for calculating parameters for the LCA and LCC models were calculations related to biomethane upgrading and water flows in distillation columns. The biogas obtained from AD is then upgraded to biomethane by the use of water scrubbing technology, one of the most used techniques when it comes to large systems (>100 m³/h) [228], [229], [230]. The principle relies on the biogas' CO₂ and H₂S higher solubility in water than methane's, something described by Henry's law (see Equation 2), which explains the relation between the concentration of a gas in a liquid in contact with such gas, and the partial pressure of the gas [231].

$$C_A = K_H \cdot \rho_A \quad (\text{Equation 2})$$

where,

C_A : molar concentration of an A gas in the liquid;

K_H : Henry's constant;

ρ_A : gas's partial pressure.

Within a high-pressure absorption column (high pressure boosts the dissolubility of gases in water [232][45], carbon dioxide is removed from the raw biogas, dissolved into the water, and sprayed from the top of the scrubber in counter-current to the biogas. Some carbon dioxide, along with traces of methane, is released from the water in the flash column and recirculated into the main biogas stream. The amount of water necessary to sequestrate a certain amount of carbon dioxide, as represented in Equation 3, depends on the desired CO₂ concentration in the upgraded gas, the solubility of the carbon dioxide in the water, which is influenced by temperature and pressure in the scrubber, and on the column design [230], [231].

$$Q_w(l/h) = \frac{Q_{CO_2}(g)(mol/h)}{C_{CO_2}(aq)(M)} \quad (\text{Equation 3})$$

where,

Q_w : water flow needed in the column;

Q_{CO_2} : molar flow to be removed from the biogas;

C_{CO_2} : calculated carbon dioxide solubility (represented as the maximum concentration in the water) using Equation 2.

A full description of the detailed LCI collection can be found in Article #5. Nevertheless, a summary of all the main inventory is shown in Table 4.10.

Table 4.10. LCI for food waste valorization case study

Material	Amount	Unit
Anaerobic Digestion		
Food waste	36500	t
Anaerobic digestion plant (construction)	0.146	p
Municipal waste collection service by 21 metric ton lorry	5.48E05	tkm
Water	365	t
DOC in FW	15 %	
Electricity (internally supplied from CHP)	1.47E+06	kWh
Heat (internally supplied from CHP)	12337	MJ
Sludge from anaerobic digestion (emission)	30438	t
Biogas (output)	609.9	kmol/day
Biogas density [40]	1.187	g/L
Upgrade		
Air compressor	0.2	p
Absorption column	0.05	p
Softened water	122.8	t
Electricity (internally supplied from CHP)	1.53E+06	kWh
Methane stream (output)	365.9	kmol/day
Carbon dioxide (biogenic)	3.86E03	t
Wastewater treatment	122.8	t
CHP		
Construction work, heat, and power cogeneration unit, 160 kW	0.625	p
Lubricating oil	2663.7	kg
Carbon dioxide, biogenic (emissions)	4972150.7	kg
Carbon monoxide, biogenic (emissions)	14206.1	kg
Particulates, < 2.5 um (emissions)	13.3	kg
Sulfur dioxide (emissions)	48.8	kg
Other emissions (dinitrogen monoxide, methane, nitrogen oxides, NMVOC, etc.)		
Waste mineral oil (waste treatment)	2663.7	kg

In this study, a C-LCC is conducted following the exact system boundaries of the LCA model, a gate-to-gate approach. Nevertheless, for this economic evaluation, a full-scale plant considering the annual average food waste landfilled value in Mondonedo is modeled to include the effects of the economy of scales, maximizing cost efficiency by increasing production [233].

Regarding the S-LCA, the stakeholders and impact categories selection has followed the latest guidelines proposed by the Society of Environmental Toxicology and Chemistry (SETAC) and the UNEP [183]. The main stakeholders are the local community, consumers, workers, and society. The evaluated indicators were chosen based on the available information and interviews with landfill workers: local employment, community engagement, safe and healthy living conditions, fair salary, health and safety, social benefits, public commitment to sustainability issues, and contribution to economic development [234].

Main results. The environmental impact assessment of the proposed FW valorization scenario was evaluated using SimaPro 9.2 [235], and the LCI datasets were taken from the Ecoinvent database v.3.7 [236]. The chosen method for calculating the potential environmental impacts is IMPACT 2002+ [162], [163], available in the SimaPro libraries. The impact on the midpoint categories is visually presented in Fig. 4.14.

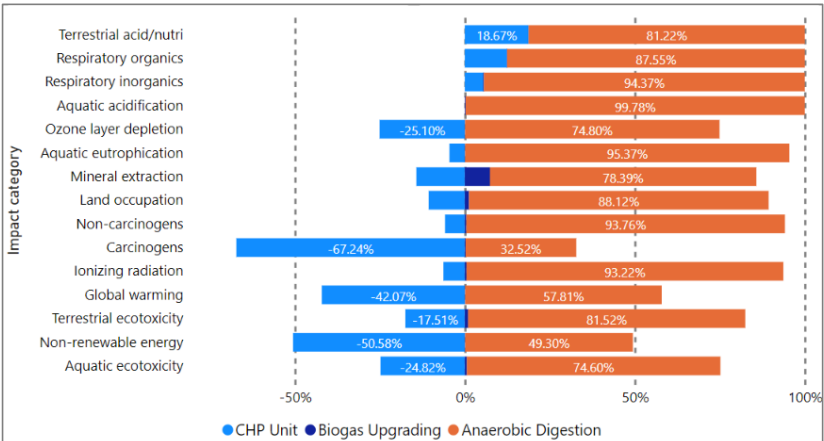

Fig. 4.14. Characterization results for the proposed valorization scenarios.

The environmental impact shares by the Mondonedo plant in the four main damage categories or areas of protection (Climate change, Ecosystem Quality, Human Health, and Resource use) can be seen in Fig. 4.15. The aggregation of mid-point impact categories into damage categories is achieved using a specific set of weighting factors given by the chosen LCA method. As seen, the electricity and heat production at the CHP plant generates credits that can almost compensate for the burdens created by the other stages in resource use and climate change areas of protection.

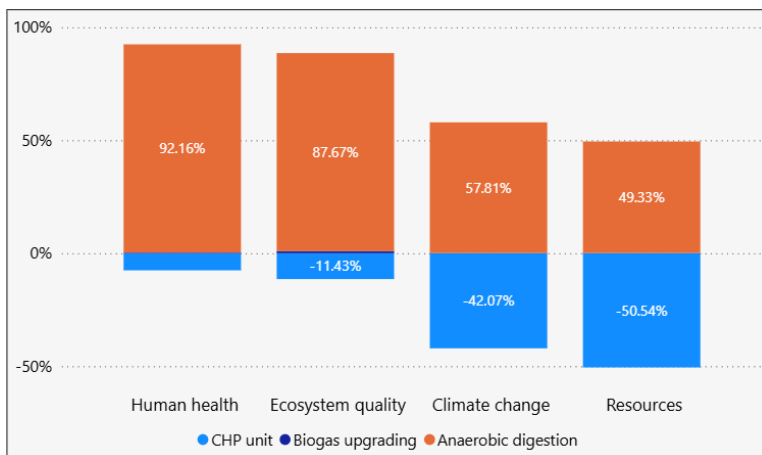

Fig. 4.15. Damage assessment results for the proposed valorization scenario.

Overall, the single total score for the Mondonedo plant is 506 Pt, with the digester sludge treatment as the most critical hotspot with 515 Pt, followed by transport of the sorted FW to the facilities with 247 Pt, and the construction of the AD plant with 79.8 Pt. The environmental benefits reported with 339 Pt are attributed to electricity and heat production and are envisioned as avoided products with 219 and 217 Pt, respectively.

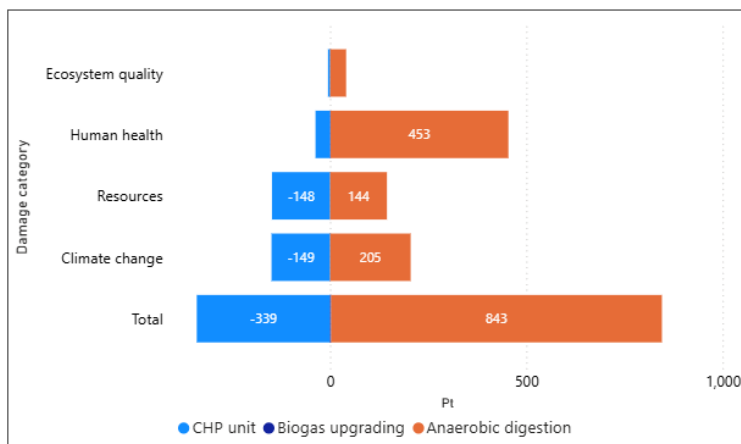

Fig. 4.16. Weighted totalized results for the proposed valorization scenarios.

For the project evaluation, three socio-economic indicators were estimated: NPV, IRR, and the PI. The evaluation resulted in an NPV of USD 112,248,095, an IRR of 16.25 %, and a PI of 3.43, proving the project's economic feasibility. A detailed CAPEX and OPEX structure are provided in Article #5.

It is believed that by doing a controlled separation of waste and by biomethane cogeneration, the health and safety conditions of workers can improve as a result of labor formalization and the mandatory use of personal protection equipment and mechanisms for the execution of activities within the landfill and energy plant, reducing the risks of negative effects for local communities. It is worth noting that, although the study projects new job creation as

one of its positive impacts, local communities perceive that these jobs often exclude the local labor force and instead hire professionals from other regions.

In safe and healthy local communities, the human health aspect presents an issue in environmental evaluation. Thus, it is essential to evaluate end-of-pipe technologies to reduce the emissions of substances affecting the areas of respiratory organics and non-carcinogens, thereby diminishing this concern. The proposed project would contribute to the country's economic development and serve as a positive sign for governmental bodies and decision-makers regarding their commitment to sustainability.

4.2. Summary of different scenarios

Each case study employs a unique system boundary within its LCA framework, leading to nuanced insights about energy efficiency and environmental impacts. This diversity in system boundaries not only reflects the specific characteristics of each FSC but also allows for a deeper understanding of how LCA modeling can be adapted to different contexts, uncovering opportunities for improvement that may otherwise remain hidden.

The first case study on the beef cold chain focused on a specific boundary, zooming in on processing and waste management, while also paying attention to the changes resulting from distributing the food product at the local or international level. This approach enabled a detailed analysis of biowaste transformation through anaerobic digestion, demonstrating that incorporating biogas recovery into the system could not only reduce greenhouse gas emissions but also offset energy demand at other stages of the supply chain. While this boundary excluded consumer-facing stages, such as transportation to the household and refrigeration, the depth of analysis within the processing phase revealed that energy recovery from waste could help balance a significant amount of the environmental impact in the FSC. This highlights how selective boundary choices can focus on key stages with high environmental leverage, even if the entire lifecycle is not included in the analysis.

The second case study focused on the fishery cold supply chain and adopted a similar system boundary, which includes all stages, from fish processing through freezing to final transportation and storage at supermarket cabinets. By considering the energy inputs across these multiple phases, this study highlighted the significant energy burden associated with the refrigeration process at the supermarket, which accounted for a substantial proportion of the overall impact, as measured by a single score. Given the energy demand for maintaining chilled or super-chilled conditions, the transport distance was found to play a significant role in the overall environmental burden, which again highlights the advantage of local or short supply chains. This approach enabled the study to recommend targeted interventions, such as refrigerant optimization and the valorization of organic waste at the processing stage, illustrating how focusing on the entire chain, rather than individual stages, can reveal substantial opportunities for energy savings that would be missed within narrower system boundaries.

The third case study, which dealt with the production of eggs and their distribution, employed a boundary that covered both production and post-processing storage, but excluded the consumer and waste phases. This intermediate approach allowed the study to investigate

inefficiencies in refrigeration and packaging without being hindered by later stages, where data might be less reliable. Here, LCA modeling showed that, in general, eggs produced by free-range hens have a higher environmental impact due to their additional calorific consumption and, consequently, impact on food production.

Finally, the food valorization scenario case study expanded the system boundaries to focus on the end-of-life phase. Furthermore, this case study also focused on implementing some S-LCA KPIs for workers and community stakeholders. This perspective highlighted the relevance of the holistic evaluation of the three sustainability pillars in sustainability assessment. By including a circular economy system, such as the valorization of organic material in food waste for energy production, it was demonstrated how although there are impacts from conducting an economic activity represented by the AD and CHP processes, once the electricity and heat produced are accounted in a system expansion system, benefits to the environment can be created by displacing other traditional power and thermal generation methods. Moreover, projects of this type can be economically feasible and enhance the quality of life for local communities.

These findings demonstrate the importance of including the full lifecycle in LCA modeling when evaluating long-term sustainability, as the environmental trade-offs of new technologies can sometimes reflect benefits that can only be spotted by a holistic approach to the problem.

Through these case studies, it becomes clear that the choice of system boundaries in LCA modeling is not merely a technical detail but a strategic decision that profoundly shapes the conclusions of each study. By adjusting these boundaries to focus on different phases of the cold chain, each study reveals distinct aspects of energy efficiency and environmental impact that might be overlooked in a more uniform approach (see Fig. 4.17). This comparative perspective highlights the importance of flexible and context-specific LCA boundaries, enabling the identification of tailored energy efficiency measures that align with the unique demands of each supply chain.

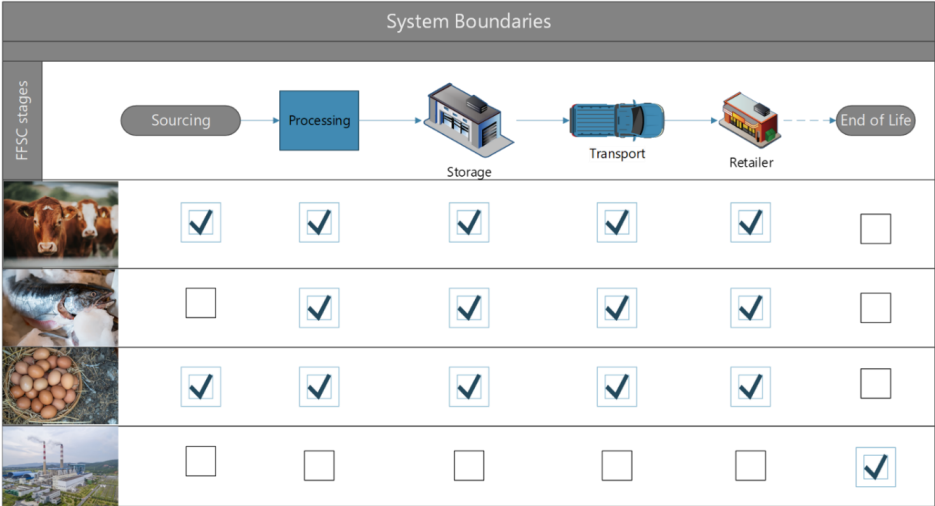

Fig. 4.17. System boundaries summary.

5. LIFE CYCLE SUSTAINABILITY TOOL

Developing an LCST for use in FSCs is essential to address the complexities and high costs associated with conventional LCA methods. These types of tools enable a simplified and expedited approach to evaluating environmental, economic, and social impacts across various stages of the food supply chain, minimizing the need for costly software or expert consultation.

Standard LCA software, like SimaPro or GaBi, can be complex and resource-intensive, often requiring significant expertise to model systems and interpret results effectively. This complexity can deter small and medium-sized enterprises from conducting comprehensive assessments, especially in sectors with high refrigeration and energy costs, such as the food industry. By contrast, simplified and standardized tools designed to focus on a specific product category or sector, such as the FSC, enable companies to identify energy and environmental "hot spots" across supply chain stages much more easily. Such tools facilitate benchmarking by leveraging the field of assumptions and background datasets, saving time, and allowing companies to prioritize energy-saving measures. This reduces data collection and processing time while providing actionable insights through user-friendly interfaces.

Furthermore, tailor-made tools can democratize LCA processes by offering cost-effective alternatives to expensive, software-based LCAs. This democratization supports sustainability goals and provides financial benefits by highlighting energy efficiency measures, which can reduce operational costs and environmental impact. In particular, a tool tailored to food supply chains can promote the adoption of circular economy principles, helping companies optimize energy use, reduce emissions, and valorize waste. Thus, the developed LCST supports a more sustainable and economically viable transition within food supply chains, particularly for resource-limited organizations.

The developed LCST simplifies complex environmental assessments for users, offering insights into global warming potential, energy demand, and water scarcity. The embedded LCC capabilities calculate key economic indicators, such as NPV and IRR, while integrating social costs by factoring in GHG emissions.

The tool, fully developed by this Thesis author, enables the input of foreground data (activity data), utilizing the Ecoinvent database 3.6 as the source for background data and normalization of inventory flows. It outputs results through charts, tables, and graphs, enabling users to easily identify hotspots. Users can assess specific products and supply chains (regional or global) by selecting stages for evaluation, with the tool automatically adjusting boundaries.

The database contains a wide range of data for users to develop models. This data includes information on transport vehicles, distances, fuels, storage, and waste scenario operations. The data is processed using inventory data obtained from the Ecoinvent database 3.6. Specifically, conversion factors are applied to normalize the data to 1 kg of the chosen food product.

The tool provides output data through various methods, each serving distinct needs. The user interface offers a range of visual representations, including simplified charts, result tables with raw data per stage, and graphs for identifying hotspots.

The LCST enables the user to select the specific product type for assessment, taking into account its LCA production. The tool also finds out whether regional or global cold chains

should be represented. It automatically expands the limits by incorporating the necessary stages to evaluate the latest chain form.

Conversely, the LCC tool exclusively depends on foreground data provided by the user. However, the tool also includes a database with fundamental economic values that may be modified by the user as necessary. The central component of the LCC tool encompasses different methodologies, including conventional, environmental, and societal LCC, each providing distinct perspectives for evaluation.

Please select the type of product to model a cold chain for Please specify the product Select the type of cold chain to model, Global or Regional		Meat Poultry Seafood Dairy Eggs, offal, rabbit or poultry Regional		FUNCTIONAL UNIT (FU) - 1 kg of delivered product																																																																																																												
<p>TRANSPORT FROM FEEDSTOCK PRODUCER TO PROCESSOR</p> <p>Is refrigeration accomplished by an auxiliary fueled unit? Please choose the type of vehicle(s) involved in this stage of the supply chain</p> <table border="1"> <thead> <tr> <th>Distance (km)</th> <th>Travel Time (hrs)</th> <th>Amount Flaw Material</th> <th>Refrigerant</th> <th>Production Country Annual initial</th> <th>Fuel (only for refrigeration units)</th> <th>Electrical Power (kWh)</th> </tr> </thead> <tbody> <tr> <td>Lorry 3.5-7.5 ton R134a-freezing</td> <td>100</td> <td>2</td> <td>6,000</td> <td>R404a</td> <td>100.0</td> <td>50.0</td> </tr> <tr> <td>1</td> <td>0</td> <td>0</td> <td>0</td> <td>R134a</td> <td>-</td> <td>-</td> </tr> <tr> <td>2</td> <td>0</td> <td>0</td> <td>0</td> <td>R22</td> <td>-</td> <td>-</td> </tr> <tr> <td>3</td> <td>0</td> <td>0</td> <td>0</td> <td>R22</td> <td>-</td> <td>-</td> </tr> <tr> <td>4</td> <td>0</td> <td>0</td> <td>0</td> <td>R404a</td> <td>-</td> <td>-</td> </tr> </tbody> </table> <p>Water consumption per year</p> <table border="1"> <thead> <tr> <th>Amount</th> <th>Unit</th> </tr> </thead> <tbody> <tr> <td>Tap Water</td> <td>5</td> <td>m³</td> </tr> <tr> <td>Underground Well Water chemically treated</td> <td>3</td> <td>m³</td> </tr> </tbody> </table> <p>SEC (kWh/kg) 0.19</p>						Distance (km)	Travel Time (hrs)	Amount Flaw Material	Refrigerant	Production Country Annual initial	Fuel (only for refrigeration units)	Electrical Power (kWh)	Lorry 3.5-7.5 ton R134a-freezing	100	2	6,000	R404a	100.0	50.0	1	0	0	0	R134a	-	-	2	0	0	0	R22	-	-	3	0	0	0	R22	-	-	4	0	0	0	R404a	-	-	Amount	Unit	Tap Water	5	m ³	Underground Well Water chemically treated	3	m ³																																																									
Distance (km)	Travel Time (hrs)	Amount Flaw Material	Refrigerant	Production Country Annual initial	Fuel (only for refrigeration units)	Electrical Power (kWh)																																																																																																										
Lorry 3.5-7.5 ton R134a-freezing	100	2	6,000	R404a	100.0	50.0																																																																																																										
1	0	0	0	R134a	-	-																																																																																																										
2	0	0	0	R22	-	-																																																																																																										
3	0	0	0	R22	-	-																																																																																																										
4	0	0	0	R404a	-	-																																																																																																										
Amount	Unit																																																																																																															
Tap Water	5	m ³																																																																																																														
Underground Well Water chemically treated	3	m ³																																																																																																														
<p>TRANSPORT FROM AGRICULTURE PRODUCTION TO PROCESSOR</p> <p>Does user want to create their own food product and impact per category data set? If yes, please use the following fields</p> <p>Insert product name</p> <table border="1"> <thead> <tr> <th>Amount</th> <th>Unit</th> </tr> </thead> <tbody> <tr> <td>Eggs</td> <td>5000</td> <td>kg</td> </tr> <tr> <td>Impact category's values per FU</td> <td>1000</td> <td>kg</td> </tr> <tr> <td>GWP (kg CO₂ eq)</td> <td>5</td> <td>kg</td> </tr> <tr> <td>CEM (MJ)</td> <td>10</td> <td>MJ</td> </tr> </tbody> </table> <p>Temperatures for transport and Storage</p> <table border="1"> <thead> <tr> <th>Amount</th> <th>Unit</th> </tr> </thead> <tbody> <tr> <td>Transport temperature (-20 to +20 °C)</td> <td>15</td> <td>°C</td> </tr> <tr> <td>Storage temperature (-20 to +20 °C)</td> <td>-2</td> <td>°C</td> </tr> </tbody> </table> <p>Packaging Materials</p> <table border="1"> <thead> <tr> <th>Amount</th> <th>Unit</th> </tr> </thead> <tbody> <tr> <td>Polyethylene, low density, granulate</td> <td>200</td> <td>kg</td> </tr> <tr> <td>Ethylvinylacetate, foil</td> <td>40</td> <td>kg</td> </tr> <tr> <td>Packaging film, low density polyethylene</td> <td>60</td> <td>kg</td> </tr> <tr> <td>Total amount to transport (Payload)</td> <td>5,300</td> <td>kg</td> </tr> <tr> <td>Total amount to transport (Total product + packaging materials)</td> <td>100,000</td> <td>kg</td> </tr> </tbody> </table> <p>STORAGE AFTER PROCESSING</p> <p>Country where the processing and warehouse facilities are located at: Estoria</p> <p>Water consumption per year</p> <table border="1"> <thead> <tr> <th>Amount</th> <th>Unit</th> </tr> </thead> <tbody> <tr> <td>Tap Water</td> <td>300</td> <td>m³</td> </tr> <tr> <td>Underground Well Water chemically treated</td> <td>800</td> <td>m³</td> </tr> </tbody> </table> <p>Energy consumption per year</p> <table border="1"> <thead> <tr> <th>Amount</th> <th>Unit</th> </tr> </thead> <tbody> <tr> <td>Electricity from the grid</td> <td>10,000.0</td> <td>kWh</td> </tr> <tr> <td>Electricity from natural gas</td> <td>500.0</td> <td>kWh</td> </tr> <tr> <td>Other energy sources (per year)</td> <td>100.00</td> <td>Unit</td> </tr> <tr> <td>Heavy fuel oil, rest of Europe</td> <td>800.00</td> <td>kg</td> </tr> <tr> <td>natural gas, low pressure</td> <td>100.00</td> <td>m³</td> </tr> <tr> <td>Refrigerant loss per year (Initial annual precharge)</td> <td>60.00</td> <td>kg</td> </tr> <tr> <td>R134a</td> <td>60.00</td> <td>kg</td> </tr> <tr> <td>Storage time at the warehouse</td> <td>30</td> <td>days</td> </tr> <tr> <td>Warehouse size</td> <td>200</td> <td>m²</td> </tr> <tr> <td>Warehouse Total size</td> <td>200</td> <td>m²</td> </tr> <tr> <td>Payload Volume</td> <td>8.0</td> <td>m³</td> </tr> </tbody> </table> <p>WASTE SCENARIO</p> <table border="1"> <thead> <tr> <th>Type and Waste disposal scenario per year</th> <th>Amount</th> <th>Unit</th> <th>Type of vehicle for waste disposal</th> <th>Distance</th> </tr> </thead> <tbody> <tr> <td>Slaughterhouse waste rendering to tallow and meal</td> <td>700.0</td> <td>kg</td> <td>Lorry 16-32 Euro 6</td> <td>70.0</td> </tr> <tr> <td>Biodegradable waste to anaerobic digestion</td> <td>250.0</td> <td>kg</td> <td>Lorry 16-32 Euro 6</td> <td>20.0</td> </tr> <tr> <td>Slaughterhouse waste to municipal incineration</td> <td>250.0</td> <td>kg</td> <td>Lorry 16-32 Euro 6</td> <td>20.0</td> </tr> <tr> <td>Wastewater to average wastewater treatment plant</td> <td>250.0</td> <td>m³</td> <td>Lorry 16-32 Euro 5</td> <td>20.0</td> </tr> </tbody> </table>						Amount	Unit	Eggs	5000	kg	Impact category's values per FU	1000	kg	GWP (kg CO ₂ eq)	5	kg	CEM (MJ)	10	MJ	Amount	Unit	Transport temperature (-20 to +20 °C)	15	°C	Storage temperature (-20 to +20 °C)	-2	°C	Amount	Unit	Polyethylene, low density, granulate	200	kg	Ethylvinylacetate, foil	40	kg	Packaging film, low density polyethylene	60	kg	Total amount to transport (Payload)	5,300	kg	Total amount to transport (Total product + packaging materials)	100,000	kg	Amount	Unit	Tap Water	300	m ³	Underground Well Water chemically treated	800	m ³	Amount	Unit	Electricity from the grid	10,000.0	kWh	Electricity from natural gas	500.0	kWh	Other energy sources (per year)	100.00	Unit	Heavy fuel oil, rest of Europe	800.00	kg	natural gas, low pressure	100.00	m ³	Refrigerant loss per year (Initial annual precharge)	60.00	kg	R134a	60.00	kg	Storage time at the warehouse	30	days	Warehouse size	200	m ²	Warehouse Total size	200	m ²	Payload Volume	8.0	m ³	Type and Waste disposal scenario per year	Amount	Unit	Type of vehicle for waste disposal	Distance	Slaughterhouse waste rendering to tallow and meal	700.0	kg	Lorry 16-32 Euro 6	70.0	Biodegradable waste to anaerobic digestion	250.0	kg	Lorry 16-32 Euro 6	20.0	Slaughterhouse waste to municipal incineration	250.0	kg	Lorry 16-32 Euro 6	20.0	Wastewater to average wastewater treatment plant	250.0	m ³	Lorry 16-32 Euro 5	20.0
Amount	Unit																																																																																																															
Eggs	5000	kg																																																																																																														
Impact category's values per FU	1000	kg																																																																																																														
GWP (kg CO ₂ eq)	5	kg																																																																																																														
CEM (MJ)	10	MJ																																																																																																														
Amount	Unit																																																																																																															
Transport temperature (-20 to +20 °C)	15	°C																																																																																																														
Storage temperature (-20 to +20 °C)	-2	°C																																																																																																														
Amount	Unit																																																																																																															
Polyethylene, low density, granulate	200	kg																																																																																																														
Ethylvinylacetate, foil	40	kg																																																																																																														
Packaging film, low density polyethylene	60	kg																																																																																																														
Total amount to transport (Payload)	5,300	kg																																																																																																														
Total amount to transport (Total product + packaging materials)	100,000	kg																																																																																																														
Amount	Unit																																																																																																															
Tap Water	300	m ³																																																																																																														
Underground Well Water chemically treated	800	m ³																																																																																																														
Amount	Unit																																																																																																															
Electricity from the grid	10,000.0	kWh																																																																																																														
Electricity from natural gas	500.0	kWh																																																																																																														
Other energy sources (per year)	100.00	Unit																																																																																																														
Heavy fuel oil, rest of Europe	800.00	kg																																																																																																														
natural gas, low pressure	100.00	m ³																																																																																																														
Refrigerant loss per year (Initial annual precharge)	60.00	kg																																																																																																														
R134a	60.00	kg																																																																																																														
Storage time at the warehouse	30	days																																																																																																														
Warehouse size	200	m ²																																																																																																														
Warehouse Total size	200	m ²																																																																																																														
Payload Volume	8.0	m ³																																																																																																														
Type and Waste disposal scenario per year	Amount	Unit	Type of vehicle for waste disposal	Distance																																																																																																												
Slaughterhouse waste rendering to tallow and meal	700.0	kg	Lorry 16-32 Euro 6	70.0																																																																																																												
Biodegradable waste to anaerobic digestion	250.0	kg	Lorry 16-32 Euro 6	20.0																																																																																																												
Slaughterhouse waste to municipal incineration	250.0	kg	Lorry 16-32 Euro 6	20.0																																																																																																												
Wastewater to average wastewater treatment plant	250.0	m ³	Lorry 16-32 Euro 5	20.0																																																																																																												

Fig. 5.1. Input parameter interface (1).

The design of the tool interface prioritizes user-friendliness, employing a color-coded system to distinguish between different cell types, including scrollable lists, editable fields, and cells that automatically calculate values. In developing the tool, the primary objective, aside from adhering to the standards outlined in ISO 14040 and ISO 14044, was to devise a resource that allows supply chain managers to assess various sustainability facets from an LCT perspective without necessitating expertise in LCA, LCC, or S-LCA. Consequently, users are relieved from the need to perform calculations themselves, with their principal responsibility being to maintain the accuracy and consistency of the data they input.

All stages are consolidated into a single sheet to track and modify previously entered values easily. For immediate feedback, preliminary results are displayed as bar charts, allowing more experienced users to quickly assess the logic and scale of the results. The tool is structured to

conceal calculation sheets and protect the database libraries, preventing unintended alterations to conversion factors that could impact the output data.

This tool enables the construction of product systems, allowing users to choose various elements, including the type of supply chain (regional or global), a range of input materials (such as food products and packaging materials), modes of transport, distances, travel durations, payloads, energy sources, and other necessary materials or substances for the model. Additionally, the tool facilitates the development of waste treatment scenarios downstream, an optional feature that can be utilized for sensitivity analysis (see Fig. 5.1 and Fig. 5.2). The environmental impacts derived from the LCA are quantified using three distinct methodologies across three primary impact categories: GWP measured in CO₂ equivalent via the IPCC100a method, energy intensity quantified in megajoules using the Cumulative Energy Demand method, and water scarcity assessed in cubic meters employing the AWARE methodology.

The LCA provides a comprehensive perspective on the environmental efficacy of a specific food chain scenario, encompassing its various stages and associated input and output processes. The ecological impact extends beyond individual stakeholders, bearing significance at regional, national, and societal levels. Consequently, the LCST offers a broad and detailed assessment of the environmental implications of a particular supply chain.



Fig. 5.2. Input parameter interface (2).

5.1. LCA output indicators

The output indicators encompass all activities associated with a supply chain over a one-year period. To model the intended product, input data should be provided on an annual basis. However, it is possible to model data for a more straightforward scenario, such as a specific single-occurrence supply chain, although this may require a more advanced understanding of the tool.

The tool background data is all based on a cradle-to-gate system; hence, when assessing the GWP from using 1 kg of light fuel oil, it not only considers the direct emissions from its combustion as an energy source. Instead, it also includes the emissions associated with its entire life cycle, encompassing extraction activities, raw materials, infrastructure, and the transportation of the material.

The three selected LCA-output indicators or impact categories considered in the ICCEE LCA tool are:

- GWP expressed in kilograms of CO₂ equivalent and based on the IPCC 2013 method (with a 100-year time horizon), which follows the previous IPCC 2007 methodology [237]. This approach, devised by the Intergovernmental Panel on Climate Change, incorporates climate change factors from IPCC assessments over a century. The fundamental concept is to establish a quantitative method for comparing the effects of various gases on global warming. Essentially, it evaluates the amount of energy that one ton of a particular gas will absorb over a certain period compared to the emissions of one ton of carbon dioxide (CO₂).
- Cumulated energy demand (CED) in MJ is the accumulated energy required, including all background processes. CED is a methodology employed in Life Cycle Impact Assessment. It measures direct and indirect energy consumption across a product or process's life cycle, expressed in megajoules (MJ). The CED methodology considers primary energy, encompassing both renewable and non-renewable sources, and accounts for energy flows used for energy generation and material production, quantified in MJ. This method is advantageous for assessing and contrasting the energy intensity of various processes [238], [239].
- Water scarcity in m³ equivalent measures the potential of water deprivation to humans or ecosystems. It is understood as the available water remaining in a watershed (AWARE methodology) after accounting for the consumption by humans and aquatic systems [240]. The primary aim of AWARE is to gauge the degree of water scarcity risk faced by other users in a specific region. It can calculate the water scarcity footprint according to the ISO 14046 standard. This method examines the potential for water deprivation impacting humans or ecosystems based on the principle that lower water availability per area increases the likelihood of deprivation for another user. In May 2016, the European Union's Joint Research Centre endorsed this method. AWARE is intended for use as a water use midpoint indicator in life cycle impact assessment, as per ISO 14044.

The calculation procedure for the three environmental impact categories included in the tool is represented by:

$$\text{Output indicator} = \text{input value}(kg) \times \text{characterization factor}\left(\frac{\text{emissions}}{kg}\right) \quad (\text{Equation 4})$$

A simple example of this calculation is the CED for using 10 kg of average light fuel oil in Europe.

$$10 \text{ kg} \times 52.6 \text{ MJ/kg} = 526 \text{ MJ}$$

The input data is collected following the procedure explained in the following section and must be entered into the LCST by the user. In contrast, the tool core provides the conversion factors. The outputs can be seen either in the sheet for results or directly in the graphs presented in the user dashboard (see Fig. 5.2).

5.2. LCC output indicators

Three main LCC approaches were evaluated within this Thesis: conventional, environmental, and societal. Due to the distinct methodologies employed in various kinds of LCC, diverse output indicators are utilized accordingly. The C-LCC and S-LCC exhibit notable similarities, reflected in their shared indicators. Specifically, in the context of C-LCC as adopted in the tool, the focus is predominantly on economic indicators, which include:

- Net present value (NPV): the difference between investment and the total present value of future net income (net cash flow).

$$NPV = \frac{R_t}{(1+i)^t} \quad (\text{Equation 5})$$

where,

NPV = net present value,

R_t = net cash flow at time t ,

i = discount rate,

t = time of the cash flow

- Internal rate of return (IRR): is an index illustrating the expected profit versus project investment cost. It can also be said that IRR shows the maximum loan interest rate that the project can tolerate.

$$0 = NPV = \sum_{t=1}^T \frac{C_t}{(1+IRR)^t} - C_0 \quad (\text{Equation 6})$$

where:

C_t = net cash flow during the period t

C_0 = total initial investment costs

IRR = the internal rate of return

t = the number of time periods

- Profit index (PI): is a ratio between the total present value (PV) of future income and initial investment.

$$PI = \frac{PV \text{ of future cash flows}}{\text{Initial investment}} \quad (\text{Equation 7})$$

Determining the output indicators for E-LCC assessment presents more challenges. The reason is that E-LCC primarily concentrates on estimating solely the economic aspect, or as a broader component of sustainability evaluation. Therefore, the outcomes are displayed in monetary terms for each phase of the life cycle, without applying any discount rates.

5.3. S-LCA (S-LCC) output indicators

Similar case considerations relevant to C-LCC are also applicable to S-LCC. However, S-LCC incorporates an extra component of damage cost in assessing overall cash flows. This inclusion is based on the premise that there is a willingness to pay for the societal impacts. The output indicators for S-LCC include:

- Social NPV (SNPV): It shares the exact definition of NPV but includes additional damage costs in the evaluation.
- Social cost-benefit analysis (SCBA): It is recommended when S-LCC is conducted and is found by dividing the future scenario of SNPV by the baseline scenario of SNPV. A SCBA value greater than 1.0 shows a social profit from the investment or project evaluated, while a value lower than 1.0 would show a social drawback from the project.

5.4. Data collection procedure

The initial factor to consider regarding data gathering and application in the LCST involves determining the specific data to collect. Based on the established LCA methodology, two categories of product systems are identified: the foreground and the background systems.

In the context of the LCST, the foreground system primarily focuses on delineating specific data utilization, rather than the more commonplace application of average or generic background data, a perspective known as the specificity perspective. This foreground system is characterized by processes unique to the system in question, specifically those under the direct control of the producer or another stakeholder within the supply chain.

Conversely, the background system is oriented towards identifying processes that fall within the direct control or significant influence from the standpoint of the decision context of a study, a concept referred to as the "management perspective." Due to the averaging effect across suppliers, the background system encompasses processes that are part of a homogeneous market. In these instances, average or equivalent generic data is sufficient to represent these processes. These are processes that, while part of the system, are not under the immediate control or decisive influence of the product's producer.

Within the framework of the LCST, the foreground data, which is of utmost importance, should predominantly be obtained from primary data collection activities directly involving the

actors responsible for the unit process under evaluation. This data constitutes the critical input in the LCST, which users must input throughout the tool fields. In contrast, background data collection activities are pre-suggested by the tool and form the backbone of the tool's database matrix.

The collection of foreground data is typically conducted through energy audits and site visits to the actor's company, which constitutes a part of the secondary data collection activities. Practically, the LCST offers flexibility to utilize either primary foreground data or data already integrated into the tool.

On-site foreground data collection. The most critical data to be potentially implemented in the LCST based on an energy audit or as part of the LCI step in a classic LCA process, can be divided into four parts:

1. General information about the company, encompassing the country where its principal operations are carried out, its specific food industry sector, and the operational stage of the organization. Additional vital information includes the annual product demand, conversion ratios from raw materials to finished products, the extent of space utilization in the warehouse compared to its total area or volume, and the average highest temperature during the peak of the warmest season.
2. Storage activities: This encompasses collecting yearly data on production rates, warehouse temperatures, and annual electricity usage for refrigeration, along with the consumption of any other energy sources utilized for refrigeration. An essential aspect is the warehouse utilization factor, which is crucial for normalizing energy use to the FU in the LCA framework. Therefore, information on warehouse dimensions, average product occupancy, and the typical duration of products remaining in storage must be gathered. Additionally, data on water usage, including its source and the annual consumption of refrigerants, specifying the type of refrigerant used, should be recorded. Lastly, it is necessary to account for any packaging materials employed in activities related to the unit system.
3. Transportation Operations: It is vital to gather details about the variety of vehicles utilized in the surveyed operation, including their fuel type, travel distances, and the duration taken to cover these distances. The refrigeration technology employed in these vehicles is also a key factor, as is the power source for the refrigeration unit (such as the truck engine or an auxiliary diesel engine). Furthermore, additional vital data points are collected within the scope of refrigeration activities, such as the average load capacity for each truck model, yearly refrigerant usage, and, where applicable, the annual water consumption.
4. Lastly, data on EEMs should be gathered, considering the LCST was built under the scope of the ICCEE project. Therefore, the LCST offers both standalone and comparative LCA analyses, as desired. EEMs can be found in various areas and may take different forms. Alterations in refrigeration systems often come to stakeholders' attention, followed by the enhancement or replacement of insulation materials. However, EEMs might also involve modifications in auxiliary technologies, such as ventilation or lighting systems, or building infrastructure

alterations. Additionally, EEMs along the FSC could encompass the deployment of technology for energy recovery or generation, enhancements in maintenance processes leading to energy conservation, or employee training programs that yield savings in either monetary or energy terms due to behavioral changes. Other types of EEMs include those derived from management activities, such as energy audits, adjustments in operational parameters, and the implementation of new energy management systems, as well as those arising from monitoring and control technologies and procedures.

Background data collection. The author of this Thesis conducted data acquisition for the background system in the LCST during the research period, adhering to the guidelines set out in ISO 14044 for Life Cycle Assessment, specifically following the methodology of the LCI phase. The LCI process involves gathering, organizing, and conducting an initial analysis of emissions and resource use. This step is crucial for calculating and interpreting potential impact indicators linked to the interactions of such flows with the natural environment [174]. Broadly, the background data required for the tool was categorized into groups and subgroups analogous to those of the foreground data. The information collected for each inventory item is aligned with its environmental impact, focusing on the three chosen impact categories: GWP, CED, and water scarcity. The following section provides a more precise depiction of the specific data and categories encompassed within the integrated database:

1. Transportation. This category in the tool's database includes a variety of vehicles:
 - a. Road transport. This subcategory primarily consists of trucks utilized for long-haul transport, ranging from light commercial freight vehicles to lorries with a capacity of up to 32 tons. Only diesel-engine vehicles conforming to EURO 5 and EURO 6 standards are featured.
 - b. Refrigerated road transport. This subset includes the same types of trucks as the previous category. However, a notable distinction for this group is that the collected data for impact categories pertains to vehicles where the main truck engine powers the refrigeration unit. Therefore, selecting a car from this list in the tool implies that the refrigeration unit does not need an additional power or fuel source.
 - c. Global transport. This subgroup encompasses modes of transport typically used for transoceanic freight, such as trains, aircraft, and ships.
2. Products and materials. This category consolidates manufactured or finished products, raw materials ready for distribution, and packaging materials. It is essential to recognize that the environmental impact associated with choosing any item in this group represents the cumulative effect of the upstream process of that particular product, considered from a cradle-to-gate perspective. This implies that the items in this category are not consumable or auxiliary items within a specific supply chain. However, considering the inputs entering a specific supply chain (such as fresh fish or meat), selecting a particular unfrozen product allows for the inclusion of the environmental burden associated with all its specific transformation activities necessary for processing in the downstream FSC process.

- a. Products
 - i. Dairy products. Cream, cheese, and processed milk are included in this sub-category.
 - ii. Fish products. Fresh fish, super chilled fish, and frozen fish products are included in this sub-category.
 - iii. Meat products. Poultry, frozen eggs, and meat, as well as frozen meat products, are categorized under this subcategory.
 - b. Packaging materials. Some of the main packaging materials used in the food industry nowadays are found in this category, ranging from food-grade glass to various types of polymers and plastics.
 - c. Water. The database includes various sources of water consumption, ranging from underground water to deionized water.
3. Energy Sources. An extensive array of energy sources is available within the tool, ensuring users have maximum flexibility, regardless of the type of stakeholder or stage in the cold chain they are modeling.
- a. Electricity. This sub-category encompasses two types of electrical sources:
 - i. From country mix (location-based): It includes electricity obtained from the national grid of most Eurozone countries, measured in terms of transmitting 1 kWh at a medium voltage level.
 - ii. From fuels: This list compiles electricity generated from various types of fuels, including, but not limited to, photovoltaic, natural gas, and fuel oil.
 - b. Fossil fuels. This subgroup aggregates three primary fossil fuels: natural gas, oil, and coal. Users have multiple options based on the country or region and specific fuel characteristics, such as low- and high-pressure natural gas. Unlike electricity, the units for these fuels are in mass/volume, which is an essential consideration during energy audits.
 - c. Biofuels. Common biofuels listed here include biogas, bioethanol, biomethane, methanol from biomass, and biodiesel. Similar to fossil fuels, the measurement units vary (kg or m³) depending on the type of biofuel.
 - d. Heat. This category includes various heat sources categorized by fuel type and plant size. Coal and natural gas are the primary sources, with cogeneration technology also featured. The range of options extends from small 5 kW to large 10 MW plants, encompassing district or industrial heating as potential energy sources within the model.
4. Refrigeration materials. In this category, the necessary refrigerants for refrigeration units in warehouses and transport vehicles are compiled, as well as the fuels needed for independent refrigeration units (those not powered by the main truck engine).
5. Waste disposal. This database section provides primary disposal options for common packaging materials, wastewater, slaughterhouse waste, and other biodegradable substances in the food industry. According to the selected waste treatment technology, the possibilities related to a mass material unit. The tool also

accounts for transportation to the treatment facility as part of the waste disposal scenario.

The data used to create this database are sourced from various methods and origins, all of which are recognized and employed in both academic and industrial sectors. Furthermore, all datasets align with information in the Ecoinvent 3.6 database, an ISO 14044-compliant database widely utilized in most commercial LCA software.

5.5. Data input

Material and energy flows. It is essential to note that the LCST is designed to collect all data regarding material and energy flows on an annual basis. The following are considered material flows:

- water consumption;
- electricity consumption;
- other energy sources consumption;
- refrigerants (annual pre-charge);
- waste materials.

Activity data for materials and energy flows within the tool should be inserted on an annual consumption basis, which aligns with the convenience for industrial users (such as producers or transporters), as energy audit data is typically recorded on an annual basis. For instance, in a food company, detailed data on electricity consumption for each product in the warehouse is uncommon unless there are individual warehouses for each product, which is rare, or if there has been a specific cost allocation for materials and energy flows (like utility services). Conversely, data on water, electricity, and other fuel usage can be easily obtained from the yearly records of any company engaged in the supply chain. Therefore, this annual basis is the preferred format for inputting such flows into the tool.

Payload-related data. Another crucial data category in the LCST is related to the payload. Unlike material flows, this data is not inputted on an annual basis, owing to its inherent characteristics. It involves information about the volume or mass of the product that needs to be modeled for its transportation through various stages of the cold chain. This set of data includes:

- distance traveled by each vehicle;
- travel time;
- amount of product transported per vehicle;
- the electrical power required for refrigeration and ventilation in independent units (if any);
- water consumption for any purpose within the transport activities.

Nonetheless, within the transport activities, a specific data set necessitates annual input: the annual pre-charge of refrigerant. This particular data set must always be inputted regarding

yearly consumption, as the allocation of environmental impact is determined based on the percentage of annual leakage. Therefore, the basis for calculation must align with this method.

Other data. Within the tool, additional data sets are essential for conducting accurate calculations and presenting results that align with the specified functional unit. These include information about the warehouse size, the duration the selected product remains in the warehouse before transportation, the volume of the payload, and the average yearly quantity of products stored in the warehouse. All this information is crucial for the allocation of mass and energy in the output data. It is imperative to input this data accurately, as inaccuracies can significantly impact the results.

5.6. LCA data processing and results visualization

The characterization factors incorporated in the LCST are sourced from the Ecoinvent database 3.6. They are systematically categorized into specific libraries within the LCST and organized into groups. This structuring facilitates the creation of distinct databases of characterization factors arranged according to the types of background data, as outlined in the subsection 5.4. These tailored sets of conversion factors are stored under the previously mentioned data categories within the tool.

Over time, the categorization was refined to encompass the materials and processes necessary for a practical environmental assessment of an FSC, thereby enhancing the tool's applicability. The tool allows users to add a different food product that was not initially included in the background database. In such cases, tool users must provide the product's ecological profile for the three specified impact categories (GWP, CED, and water scarcity) arising from the agricultural process, following a cradle-to-gate approach. Additionally, they can adjust storage and transport temperatures for the product as it moves through the FSC. A decision feature (Yes/No) is integrated to determine whether user-provided data should be used in the LCA calculation. This option must be selected correctly to ensure accurate results.

Once the libraries for various categories are established, a core calculation Excel sheet was generated. This sheet processes the input data for each stage of the cold chain (as shown in Fig. 5.1), utilizing the conversion factors from the libraries.

A preliminary glimpse of the final results can be observed directly from the graph beside each stage box (see Figure 4.18) or in deeper detail in the “LCA results” sheet of the LCST. The LCA results are presented as follows (see Fig. 5.3):

- Total impact of the evaluated cold chain for the three impact categories, and,
- Impact per functional unit (FU) for all impact categories

<i>Total impact across the cold chain</i>	GWP (kg CO ₂ eq)	CED (MJ)	Water scarcity(m ³ eq.)
	3,603	57,167	4,246
<i>Total impact per kg transported (FU)</i>	GWP (kg CO ₂ eq)	CED (MJ)	Water scarcity (m ³ eq.)
	0.68	10.78	0.85

Fig. 5.3. General output table for LCA results.

- A chart illustrates the contribution of each stage to the analysis across different impact categories (seen Fig. 5.4). In this representation, the contribution of each process to the respective categories is detailed, which is instrumental in pinpointing environmental "hotspots."

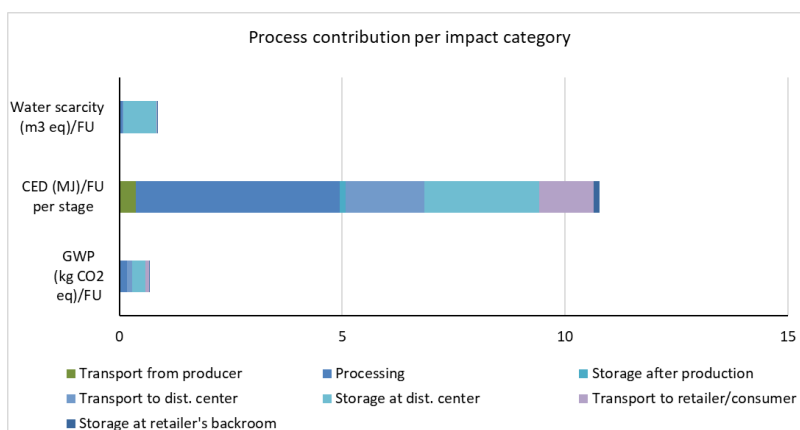

Fig. 5.4. Process contribution chart.

- A table consolidates the outcomes for each stage in the FSC and includes a column showing the cumulative impact per FU as depicted in Fig. 5.5. This table allows practitioners to review the initial output data for each stage.

No.	Cold Chain stages	GWP (kg CO ₂ eq)/FU	Cum. GWP (kg CO ₂ eq)/FU	CED (MJ)/FU per stage	Total CED (MJ)/FU along stages	Water scarcity (m ³ eq.) /FU	Cum. Water scarcity (m ³ eq.) /FU
1	Transport from Producer	0.019	0.019	0.374	0.374	0.002	0.002
2	Processing	0.154	0.173	4.564	4.939	0.067	0.069
3	Storage after production	0.007	0.181	0.141	5.080	0.013	0.082
4	Transport to Dist. Center	0.106	0.286	1.758	6.838	0.009	0.091
5	Storage at Dist. Center	0.294	0.580	2.583	9.421	0.745	0.836
6	Transport to Retailer/Consumer	0.084	0.664	1.227	10.648	0.008	0.844
7	Storage at retailer's backroom	0.015	0.679	0.132	10.779	0.005	0.849
8	Overall Waste scenario	-0.001		-0.043		-0.003	

Fig. 5.5. LCA results table per FSC stage.

- Figure 5.6 displays the proportional contribution of each process within the evaluated impact categories.

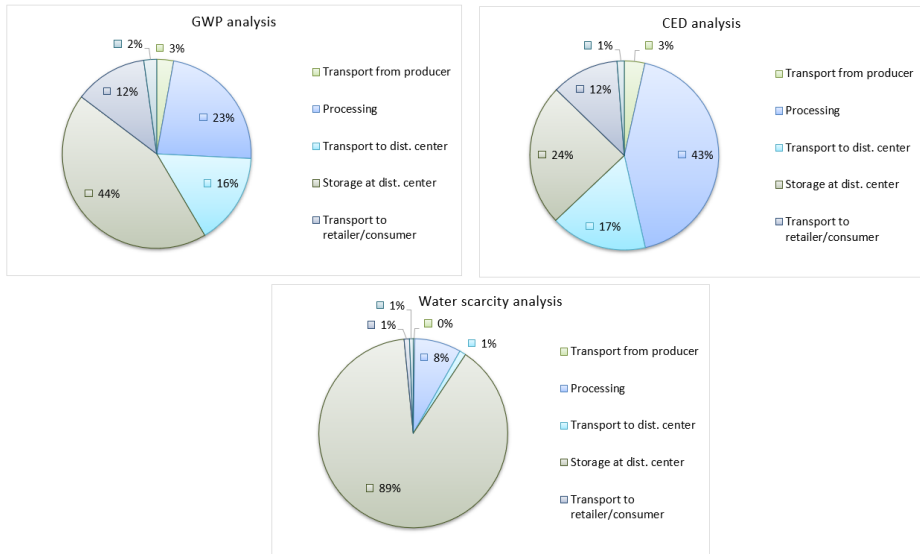

Fig. 5.6. LCA results in shares per FSC stage.

- Finally, three charts presenting the cumulated impact across subsequent stages are displayed to show the user how different outputs behave downstream of the FSC.

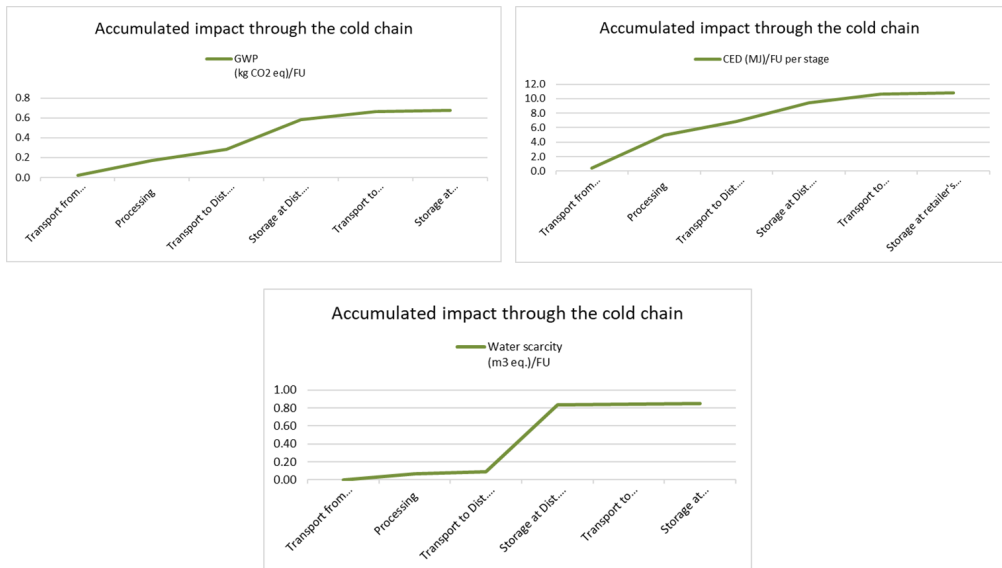

Fig. 5.7. Cumulative impacts along the FSC.

All the input and output data discussed in this section represent the baseline scenario of a specific FSC. This implies that the scenario does not incorporate any procedure enhancements or energy savings at any stage. Should EEMs be implemented, the consequent alterations in material flows must be inputted into a separate evaluation scenario.

5.7. LCC modeling

During this research, an evaluation of various EEMs was conducted, which involved different participants in the FSC, including producers, transport companies, and intermediary partners. The impact of these EEMs is primarily assessed through their effect on LCC. Consequently, the LCST tool enable users to compare up to three distinct EEMs against a baseline scenario. For this purpose, additional fields were created under “investment data entry.” In this additional sheet that works as a user interface, costs for each item previously analyzed in the LCA section are stipulated, and users have the flexibility to input their values for different regions or markets in the “Prices” box. The initial box, labeled “project costs,” is designated for inputting data related to production costs within the actor's business undergoing evaluation. Additionally, fields for the investment costs of the three EEMs are provided, allowing users to enter relevant data.

Project costs			Unit	Baseline	EEM 1	EEM 2	EEM 3	Comments
Definition costs	Project costs		€					The costs of internal expertise for the project definition phase.
	Design (calculations, internal coordination,... etc)		€					
	Technical assistance		€					The costs of external expertise (subcontracted) for the project definition phase.
Investment costs in EEM	Construction	Item 1	€		4,000	3,600	4,500	
		Item 2	€					
		Item 3	€					
	Equipments and technical installations	Item 1	€					Correspond to the program costs required beyond the definition phase: the construction costs and the purchase and installation of equipment.
		Item 2	€					
Item 3	€							
Item 4	€							
Item 5	€							
Running costs/cost categories	Operation and maintenance	Electricity	€/year	5,000	4,000	4,100	3,900	Costs for the activities conducted under the cold chain step assessed and directly performed by cost bearer or actor responsible for the stage (Internal expertise).
		Fuels	€/year	500	493	498	510	
		Labour costs	€/year					
		Water	€/year					
		Refrigerants	€/year	20	20	20	20	
	Other	€/year						
	Vehicle maintenance	€/year						
	Production costs	Raw material 1	€/year					
		Raw material 2	€/year					
		Raw material 3	€/year					
Packaging material 1		€/year						
Packaging material 2		€/year						

Fig. 5.8. Project costs and EEMs investment costs.

The EEMs need to be specified in relation to the baseline scenario to assess the impact in financial terms. Consequently, a table box labeled "Expected results from EEM" should be completed. This enables the visualization of changes compared to the performance of the baseline scenario, as illustrated in Fig. 5.9.

Expected Results from EEM			Unit	Baseline	-25	EEM 2	EEM 3	Comments
Expected results/Energy savings								
Change in electricity consumption	%			-5.0%	3.0%	-8.0%		Corresponds to the change in the different material or energy flows, and changes in operational parameters due to EEM's implementation. Please enter the corresponding values.
Change in other energy sources	%			0.0%	0.0%	0.0%		
Change in labour costs	%			0.0%	0.0%	0.0%		
Change in water consumption	%			0.0%	0.0%	0.0%		
Change in refrigerant pre-charge	%			-2.0%	-5.0%	-3.0%		
Change in quality factor	%							Corresponds to the change in the quality factor affecting the total amount of units sold per year. Please enter the corresponding values.
Change in carbon emissions (ton CO ₂ eq)	ton/year			0.0%	0.0%	0.0%	Expected amount of carbon emission reduction	

Fig. 5.9. Table for expected results from EEMs.

Typically, the primary outcome of implementing an EEM is a decrease in energy usage. Nevertheless, the LCST allows users to assess changes in other aspects, including water consumption and enhancements in the food quality factor. These improvements may impact on the quality and quantity of the product delivered after the cold chain.

The EEMs can vary in a broad range of options, and some of the most common can be:

- Improvement in ventilation and lighting systems;
- Changes in motors, pumps, and other auxiliary devices;
- Changes in equipment directly affecting the refrigeration systems;
- Improvements to the building in terms of insulation, installing curtains or separated compartments;
- Deployment of new energy recovery technologies.
- Behavioural changes from the staff resulting in energy savings;
- Improvement in maintenance procedures;
- Operational changes;
- Technological improvement of monitor and control laces;
- Direct changes in the refrigeration systems
- Improve transport activities, such as better truck insulation, optimizing travel routes, distances covered, and fuel monitoring.

The "Investment data entry" sheet in the tool includes additional fields for inputting production data and financial factors, which are subsequently utilized in the economic evaluation of EEMs using a C-LCC approach. This feature allows users to assess the economic impact within a consistent financial framework and develop various investment scenarios. These scenarios can consider elements such as the required rate of return, inflation, interest rates on loans, and the proportion of investment. The results of the C-LCC for both the baseline scenario and the potential EEMs are displayed in the "C-LCC Results" sheet. This includes cash flow tables for each option and a summary table showcasing the primary economic output indicators, as depicted in Fig. 5.10.

The LCST, as mentioned before, also provides the possibility of performing an E-LCC evaluation. By utilizing a predefined set of material and energy costs and selecting the desired EEM to undertake, the E-LCC feature calculates the cost changes in the stage where the EMM occurs. This feature enables supply chain managers to quickly detect which EEM delivers the highest cost reduction and where (see Fig. 5.11).

	N	O	P	Q	R	S	T
LIFE CYCLE COST COMPARISON (€/unit)							
	Baseline	EEM 1	EEM 2	EEM 3			
	6.13	5.86	6.30	5.69			
INVESTMENT EVALUATION COMPARISON							
	Baseline	EEM 1	EEM 2	EEM 3			
NPV	9,882	6,442	4,681	6,754			
IRR	-	44.22%	37.41%	41.84%			
PI	-	2.61	2.30	2.50			
<p><i>NPV</i>: Net Present value Is the difference between the total present value (PV) of the incoming net cash flow and the investmet (-K).</p> <p><i>IRR</i>: Internal Rate of Return shows the maximum interest rate of loan which can be tolerated by the a project. If <i>IRR</i> > <i>WACC</i>, then a investment could be accepted.</p> <p><i>PI</i>: Profit Index is a ratio between total present value PV of future income and initial investment.</p>							

Fig. 5.10. C-LCC output indicators visualization.

Please select from the droplist

In which Life cycle stage is the EEM implemented?	Transport to distribution center
Energy efficiency measure to implement?	EEM-1

Baseline scenario (€/thousands of kg delivered)						
Costs	Transport 1	Storage after processing	Transport 2	Storage at dist. center	Transport 3	Retailer backroom
Flow material cost	5.10	7.59	20.02	164.99	14.65	6.91
GWP external cost	1.60	0.42	5.97	16.64	4.75	1.45
Total E-LCC	6.70	8.02	25.99	181.63	19.40	8.36

E-LCC

Future Scenario for implemented EEM (€/thousands of kg delivered)						
Costs	Transport 1	Storage after processing	Transport 2	Storage at dist. center	Transport 3	Retailer/large consumer backroom
Flow material cost	5.10	7.59	20.13	164.99	14.65	6.91
GWP external cost	1.60	0.42	5.98	16.64	4.75	1.45
Total E-LCC	6.70	8.02	26.11	181.63	19.40	8.36

Total environmental LCC per thousand of kg transported (€)	Baseline scenario -	Future scenario (implementing EEM)
	250.10	250.22

Fig. 5.11. E-LCC results visualization.

Additionally, a final feature integrating the willingness to pay for externalities usually covered by society, such as the damage caused by climate change, is included in the LCST. The user can modify this externality cost depending on the desired approach: CO₂ cost per ton as in the EU ETS, damage costs related to environmental prices, or abatement costs following the eco-costs methodology, for example. Like the C-LCC, tables displaying expected cash flows and evaluating the socioeconomic indicators are presented for each EEM option.

Baseline scenario														
Year	0	1	2	3	4	5	6	7	8	9	10	11	12	13
Outflow														
Up-front (investment)														
On-going (O&M)														
Total standard costs														
Avoided damage cost														
Net cash flow														
Discount rate														
Discount factor	100%	90%	80%	70%	60%	50%	40%	30%	20%	10%	0%	0%	0%	0%
Discounted net cash flow														
S-LCC														
SNPV ₀	€	€	€	€	€	€	€	€	€	€	€	€	€	€

Future scenario (EEM-1)																														
Year	0	1	2	3	4	5	6	7	8	9	10	11	12	13																
Outflow																														
Up-front (investment)	(26.878)																													
On-going (O&M)		(8.678.205)	(8.206.707)	(8.482.909)	(9.767.396)	(10.060.419)	(10.362.230)	(10.673.097)	(10.993.290)	(11.323.099)	(11.662.781)	(12.012.665)	(12.373.045)	(12.744.236)																
Total standard costs	(26.878)	(8.678.205)	(8.206.707)	(8.482.909)	(9.767.396)	(10.060.419)	(10.362.230)	(10.673.097)	(10.993.290)	(11.323.099)	(11.662.781)	(12.012.665)	(12.373.045)	(12.744.236)																
Avoided damage cost			5.250	5.624	5.821	6.024	6.235	6.454	6.679	6.913	7.155	7.406	7.665	7.933																
Net cash flow	(26.878)	(8.672.955)	(3.201.083)	(3.477.088)	(3.761.371)	(4.054.182)	(4.356.777)	(4.669.418)	(4.992.290)	(5.325.524)	(5.669.371)	(6.023.861)	(6.389.145)	(6.765.272)																
Discount rate																														
Discount factor	100%	97%	94%	91%	88%	85%	82%	79%	76%	73%	70%	67%	64%	61%																
Discounted net cash flow	(26.878)	(8.412.766)	(3.049.078)	(3.324.501)	(3.608.700)	(3.901.552)	(4.203.797)	(4.516.292)	(4.839.894)	(5.174.461)	(5.520.851)	(5.879.825)	(6.251.254)	(6.636.009)																
S-LCC																														
SNPV ₀	€	(26.878)	€	(8.439.544)	€	(37.088.642)	€	(25.712.812)	€	(34.302.818)	€	(42.848.874)	€	(51.340.611)	€	(59.787.081)	€	(68.116.772)	€	(76.379.972)	€	(84.536.122)	€	(92.719.472)	€	(100.942.143)	€	(109.262.118)	€	(117.675.899)
SCBA																														
ROI/Vf			1.09	1.02	1.01	1.00	1.00	1.01	1.01	1.01	1.01	1.02	1.03	1.04																

Future scenario (EEM-2)														
Year	0	1	2	3	4	5	6	7	8	9	10	11	12	13
Outflow														
Up-front (investment)														
On-going (O&M)														
Total standard costs														
Avoided damage cost														
Net cash flow														
Discount rate														
Discount factor	100%	97%	94%	91%	88%	85%	82%	79%	76%	73%	70%	67%	64%	61%
Discounted net cash flow														
S-LCC														
SNPV ₀	€	€	€	€	€	€	€	€	€	€	€	€	€	€

Future scenario (EEM-3)														
Year	0	1	2	3	4	5	6	7	8	9	10	11	12	13
Outflow														
Up-front (investment)														
On-going (O&M)														
Total standard costs														
Avoided damage cost														
Net cash flow														
Discount rate														
Discount factor	100%	97%	94%	91%	88%	85%	82%	79%	76%	73%	70%	67%	64%	61%
Discounted net cash flow														
S-LCC														
SNPV ₀	€	€	€	€	€	€	€	€	€	€	€	€	€	€

Fig. 5.12. S-LCC results visualization.

5.8. Tool validation

The tool validation took place through the ICCEE project, which targeted SMEs for decision-making around EEMs. The validation followed the following processes:

- Conceptual Tool Validation:
- Data was collected from various supply chain stakeholders, such as suppliers, producers, and retailers, during earlier project stages. This data was used to validate several tools, focusing on the supply chain's energy consumption, lifecycle analysis, and benchmarking.
- The tools were tested using real-world supply chain data, although it was noted that not all datasets were complete enough to model entire cases.
- Each tool underwent rigorous technical validation, including system tests and user acceptance tests to ensure usability, functionality, and the absence of bugs.
- A group of energy managers and industry experts were asked to provide feedback on both the user interface and the presentation of the results. Each project partner was assigned specific tools to test, ensuring coverage across the suite of tools developed.

The results from the validation protocol were the following:

- Positive Feedback: Most users found the tools useful, with some expressing interest in using them in the future. The general usability and user-friendliness of the tools were praised, and no major data inconsistencies were reported.
- Identified Issues: Minor formatting issues were noted, such as cell width adjustments and problems with drop-down menus. Additionally, some translation inconsistencies and suggestions to change units to more intuitive measures were highlighted.
- Content Recommendations: There were requests to expand the drop-down menu options and clarify some of the instructions. The LCA tool required adjustments to calculation formulas, while others needed improvements in result presentation.

In general, the tool was well-received and provided a valuable resource for companies in the cold supply chain sector to improve energy efficiency. Some minor adjustments and bug fixes were required, but the tool met the validation criteria overall.

6. CONCLUSIONS AND RECOMMENDATIONS

Over the past five decades, the concept of sustainability has undergone a profound transformation. What was once primarily understood as a means to meet human needs has gradually evolved into an integrated approach that gives increasing prominence to ecological and social values alongside, and often above, purely economic considerations. This redefined understanding of sustainable development emphasizes the enhancement of human well-being and the safeguarding of environmental integrity, moving decisively away from the traditional association of development with economic growth alone.

In the context of the food industry and its complex supply chains, this paradigm shift has revealed a notable gap in the quantitative assessment of sustainability. Globalization has made these supply chains longer and more intricate, resulting in higher energy demand, greater resource consumption, and significant food waste across multiple stages. Despite efforts by international organizations and technological advancements to reduce losses and improve efficiency, the field of supply chain management still lacks a cohesive theoretical and methodological framework that fully integrates the three pillars of sustainability.

By considering the entire life cycle of a product or service, from raw material extraction to end-of-life, LCT enables the identification of environmental, social, and economic impacts that are often overlooked by more traditional, fragmented approaches. This comprehensive perspective is indispensable for industries seeking to optimize practices in ways that ensure both immediate gains and long-term sustainability. Yet, the practical application of LCT in the form of simple, accessible, and user-friendly tools remains underdeveloped. Many existing tools are too data-intensive, too complex, or insufficiently tailored to specific industry needs. This situation underscores the urgent need for research and innovation aimed at developing robust instruments that not only adhere to LCT principles but are also suitable for a broad range of stakeholders, including small and medium enterprises.

This doctoral research sought to address precisely this gap. It developed and tested an LCST through a series of case studies within the food sector. These applications demonstrate that, despite the inherent complexities of LCT methodologies, it is possible to design a framework that integrates the three pillars of sustainability in a practical and sector-specific way. The case studies in beef, fish, and eggs illustrate the tool's capacity to identify sustainability hotspots, assess trade-offs, and evaluate interventions that can generate both environmental and economic benefits. The beef supply chain analysis revealed that longer, globalized supply chains result in disproportionately higher environmental impacts per kilogram of product, providing a strong argument for preferring locally sourced meat. The fish case study identified fishing activities, driven by fossil fuel consumption, as the principal environmental hotspot, with retail storage also playing a major role due to the low efficiency of display cabinets. Sensitivity analysis confirmed that transport distances significantly influence environmental footprints, again supporting the case for reducing food miles. The egg supply chain analysis further demonstrated how producers and managers can benefit from even small-scale interventions, particularly through targeted energy efficiency measures.

The economic evaluations carried out alongside these environmental assessments confirmed that investments in energy efficiency are not only environmentally advantageous but

also financially sound. This provides industries and supply chain managers with a clear rationale for implementing changes that simultaneously improve sustainability performance and enhance competitiveness. The systematic application of the LCST has thus demonstrated its usefulness not only for individual producers but also for supply chain managers and policymakers, who can rely on such quantitative insights to design strategies, allocate resources, and develop supportive legislative frameworks.

6.1. Conclusions related to the objectives

This research aimed to address a critical gap in the evaluation of sustainability within the food industry: the absence of a standardized and practical framework that integrates the three pillars of sustainability into a single, quantitative assessment. Until recently, sustainability evaluations in this sector have tended to be fragmented, focusing on either environmental, economic, or social aspects in isolation. This fragmented perspective limited the capacity of industry actors, supply chain managers, and policymakers to make informed decisions that take into account the complex trade-offs between different sustainability dimensions. This Thesis has demonstrated that it is indeed possible to overcome this limitation by developing a holistic methodology based on life cycle thinking and operationalizing it in a way that is both robust and user-friendly.

One of the main conclusions of this study is that LCA, long considered a technically demanding and resource-intensive method, can be simplified without compromising its analytical rigor. The proposed LCST integrates LCA with LCC and selected S-LCA indicators, thereby providing a balanced evaluation across the environmental, economic, and social pillars. Importantly, the methodology has been standardized in a way that allows users to design and evaluate supply chain systems with minimal prior knowledge of LCA. This substantially lowers the barriers to entry for stakeholders who would otherwise be unable to apply such methods, especially SMEs and non-expert practitioners. By demonstrating the feasibility of such simplification, the research contributes to making life cycle approaches more accessible and actionable in real-world contexts.

The case study applications carried out in the beef, fish, and egg supply chains further confirm the practical utility of this tool. The analyses provided critical insights into sustainability hotspots across different stages of the food supply chain, highlighting, for example, the disproportionately high environmental burden of long-distance transport in beef supply chains, the energy-intensive nature of fishing operations in fish supply chains, and the potential for targeted interventions in egg production systems. These findings not only underscore the validity of the LCST as an evaluative framework but also demonstrate how its outputs can inform decision-making at multiple levels. For individual producers, the tool provides clear evidence of where process improvements can yield both environmental and economic benefits. For supply chain managers, it provides a systematic basis for determining where investments in efficiency or innovation will yield the greatest returns. For policymakers, it highlights areas where regulatory incentives and supportive legislation can have the most significant impact.

Another important conclusion concerns the LCST's capacity to bridge the gap between theory and practice. While academic discussions of LCT have long emphasized its conceptual value, practical applications have been limited by methodological complexity, high costs, and data requirements. This research demonstrates that it is possible to translate theoretical principles into a standardized, yet adaptable, tool that balances scientific rigor with usability. In doing so, it moves life cycle methodologies beyond the domain of experts and embeds them within the operational realities of the food sector. This achievement is especially relevant in the European context, where regulatory frameworks such as the CSRD and broader commitments to the SDGs are placing increasing demands on industries to evaluate and report on their sustainability performance.

Finally, the conclusions of this research reinforce the notion that sustainability assessment is not only a technical exercise but also a strategic enabler for transformation. The integration of environmental, social, and economic dimensions into a single framework provides stakeholders with a more comprehensive understanding of trade-offs and synergies, thereby empowering them to make informed decisions that align with long-term sustainability goals. The LCST thus contributes both theoretical advancements by expanding the operational boundaries of LCT and practical innovations by delivering a validated tool that can guide industry practice and policymaking alike.

In summary, the thesis concludes that integrating LCA, LCC, and S-LCA into a simplified and standardized methodology is both feasible and necessary for advancing sustainability assessment in the food industry. By demonstrating the operationalization of LCT through empirical case studies, the research has not only confirmed the theoretical value of life cycle approaches but has also provided a tangible instrument to support decision-making across the food supply chain.

6.2. Recommendations

The results of this doctoral research clearly point to several recommendations that can benefit industry actors, policymakers, and the academic community. Central to these recommendations is the recognition that the LCST developed in this thesis introduces a significant innovation, as it enables rapid evaluation of environmental effects when designing and comparing scenarios for food supply chains across most EU-27 countries. By simplifying the LCA methodology proposed in ISO 14040 and 14044, the tool reduces complexity while maintaining scientific rigor. Users can create product systems, adjust system boundaries, and obtain results without requiring prior expert knowledge of LCA. Unlike traditional cradle-to-grave approaches, the LCST applies gate-to-gate boundaries, thereby providing actors with a practical means of assessing sustainability at specific stages of their supply chains, while still taking into account upstream and some downstream processes connected to that stage.

This approach has several important implications. For industry actors and supply chain managers, the LCST offers a practical and accessible decision-support tool that makes sustainability evaluation both feasible and actionable. The merged LCA and LCC modules allow users to examine trade-offs across environmental and economic dimensions, while the

inclusion of social indicators extends the scope to cover the three pillars of sustainability. The tool has been designed with usability in mind, so that it can be employed not only by technical experts and large corporations, but also by small and medium-sized enterprises that often lack the resources to apply conventional, expert-driven methodologies. Nevertheless, some basic training is recommended to avoid calculation errors or misuse, ensuring that results are both accurate and consistent.

The benefits of implementing such a tool extend beyond environmental improvements. The LCST can generate clear financial advantages by highlighting measures that reduce the number of transport vehicles or encourage shifts to more efficient vehicle types, optimize energy use in refrigeration or processing stages, and support compliance with evolving regulatory standards. At the same time, it can reduce costs associated with waste disposal and resource inefficiency. Beyond the operational sphere, companies can leverage the tool's results as part of their sustainability communication strategies, gaining a competitive marketing advantage by demonstrating measurable progress in environmental and social performance to consumers, clients, and investors.

The experience of the ICCEE project further reinforces these recommendations. Companies that participated in the project discovered both their potential to improve energy efficiency and the range of non-energy benefits that such measures could generate. Benchmarking against other firms' supply chain energy performance provided valuable insights, while structured capacity-building activities, including training sessions and e-learning modules, equipped companies with the knowledge to translate assessment results into action. Building on this experience, it is strongly recommended that future dissemination of the LCST be coupled with targeted training and capacity-building programs. This will not only ensure proper tool use but also help organizations embed sustainability thinking into their operational culture.

For policymakers, the findings suggest that simplified, standardized, yet scientifically robust tools, such as the LCST, should be integrated into policy instruments and regulatory frameworks. By providing accessible mechanisms to evaluate sustainability performance, policymakers can lower compliance barriers and encourage wider adoption of sustainability assessments across the food sector. Furthermore, quantitative insights generated through the LCST can be directly employed to design more targeted policies, for instance by incentivizing local sourcing to reduce food miles, supporting energy efficiency upgrades in refrigeration, or addressing fossil fuel dependence in fisheries.

Ultimately, for the academic and educational community, the LCST serves as a valuable resource for training and education. Its accessibility makes it an excellent tool for students, early-career researchers, and practitioners who may not have advanced training in LCA, but who require practical experience with sustainability assessment. Embedding the tool in curricula, workshops, and capacity-building initiatives will contribute to the creation of a new generation of professionals able to bridge the gap between sustainability theory and industrial practice.

In summary, the LCST and its supporting framework are more than a theoretical advancement: they represent a concrete pathway for operationalizing Life Cycle Thinking in the food industry. The recommendations emerging from this study call for its adoption by

industry actors as a decision-support instrument, its integration into regulatory and policy frameworks by governments, and its use as an educational tool within academia. Together, these actions will contribute to reducing environmental burdens, enhancing economic efficiency, and reinforcing social responsibility across food supply chains, thereby advancing both the practical and theoretical dimensions of sustainable development.

6.3. Recommendations for Future Research

In addition to these practical, policy, and educational applications, this thesis highlights several avenues for future research. First, there is a need to further refine the integration of the social dimension into LCT-based tools. While the environmental and economic pillars are relatively well-developed, social sustainability remains less standardized and requires methodological innovation, particularly in capturing supply chain-level issues such as labor rights, community well-being, and fair trade practices.

Second, future research should aim to extend the LCST framework beyond the food industry to test its adaptability in other sectors characterized by complex supply chains, such as textiles, construction, or pharmaceuticals. Comparative studies would allow researchers to assess both the universality and sector-specific limitations of the methodology.

Third, as digitalization and big data analytics continue to evolve, integrating real-time data streams, blockchain-based traceability, and artificial intelligence into life cycle sustainability assessment tools will be essential. Such integration could significantly reduce data gaps and enhance the accuracy, scalability, and dynamic updating of results.

Fourth, further research is needed to explore how the LCST can be combined with planetary boundaries and absolute sustainability concepts in a more systematic way. Although this thesis introduces steps in this direction, operationalizing global limits into product- and process-level decision-support tools remains a frontier in sustainability science.

BIBLIOGRAPHY

- [1] R. Hernández Sampieri and C. F. Fernandez-Collado, *Metodología de la investigación*, Sexta edición. México D.F.: McGraw-Hill Education, 2014.
- [2] WCED, “Our common future. Oxford: Oxford university press,,” 1987.
- [3] M. Diesendorf, “Sustainability and sustainable development,” in *Sustainability: The corporate challenge of the 21st century*, Epping, 2000, pp. 19–37. [Online]. Available: <http://markdiesendorf.com/wp-content/uploads/2015/09/CorpSust2000.pdf>
- [4] T. Snegireva, G. Kayachev, A. Falaleev, and S. Kurgansky, “Human potential in the system of sustainable development,” in *E3S web of conferences*, 2019. doi: 10.1051/e3sconf/201913403014.
- [5] A. Romeiro, “Sustainable development: an ecological economics perspective,” 2013.
- [6] J. Rockström *et al.*, “A safe operating space for humanity,” *Nature*, vol. 461, no. 7263, Art. no. 7263, Sep. 2009, doi: 10.1038/461472a.
- [7] K. Raworth, “A Doughnut for the Anthropocene: humanity’s compass in the 21st century,” *The Lancet Planetary Health*, vol. 1, no. 2, pp. e48–e49, May 2017, doi: 10.1016/S2542-5196(17)30028-1.
- [8] L. Persson *et al.*, “Outside the Safe Operating Space of the Planetary Boundary for Novel Entities,” *Environ. Sci. Technol.*, vol. 56, no. 3, pp. 1510–1521, Feb. 2022, doi: 10.1021/acs.est.1c04158.
- [9] K. Richardson *et al.*, “Earth beyond six of nine planetary boundaries,” *Sci. Adv.*, vol. 9, no. 37, p. eadh2458, Sep. 2023, doi: 10.1126/sciadv.adh2458.
- [10] J. Rockström *et al.*, “Safe and just Earth system boundaries,” *Nature*, vol. 619, no. 7968, Art. no. 7968, Jul. 2023, doi: 10.1038/s41586-023-06083-8.
- [11] A. Bjørn, M. Diamond, M. Owsianiak, B. Verzat, and M. Z. Hauschild, “Strengthening the Link between Life Cycle Assessment and Indicators for Absolute Sustainability To Support Development within Planetary Boundaries,” *Environ. Sci. Technol.*, vol. 49, no. 11, pp. 6370–6371, Jun. 2015, doi: 10.1021/acs.est.5b02106.
- [12] FoodDrinkEurope, “EU Food and Drink Industry,” 2016. Accessed: Jan. 12, 2024. [Online]. Available: https://www.triptolemos.org/wp-content/uploads/2017/02/0184_2016_IA_Dades-agroalimentaria-UE-2015.pdf
- [13] Deloitte, “Energy efficiency in Europe - The levers to deliver the potential,” Deloitte, 2016. Accessed: Jan. 12, 2024. [Online]. Available: <https://www2.deloitte.com/content/dam/Deloitte/global/Documents/Energy-and-Resources/energy-efficiency-in-europe.pdf>
- [14] D. Coulomb, “Refrigeration and cold chain serving the global food industry and creating a better future: two key IIR challenges for improved health and environment,” *Trends in Food Science & Technology*, vol. 19, no. 8, pp. 413–417, Aug. 2008, doi: 10.1016/j.tifs.2008.03.006.
- [15] G. Liu, “The impact of supply chain relationship on food quality,” *Procedia Computer Science*, vol. 131, pp. 860–865, 2018, doi: 10.1016/j.procs.2018.04.286.
- [16] M. M. Aung and Y. S. Chang, “Traceability in a food supply chain: Safety and quality perspectives,” *Food Control*, vol. 39, no. 1, pp. 172–184, 2014, doi: 10.1016/j.foodcont.2013.11.007.
- [17] S. H. Gheewala, N. Jungbluth, B. Notarnicola, B. Ridoutt, and H. van der Werf, “No simple menu for sustainable food production and consumption,” *Int J Life Cycle Assess*, vol. 25, no. 7, pp. 1175–1182, Jul. 2020, doi: 10.1007/s11367-020-01783-z.
- [18] FAO, “The State of Food and Agriculture 2019. Moving forward on food loss and waste reduction,” in *the State of the World*, 2016, pp. 1–439.
- [19] C. Arias Bustos and E. H. M. Moors, “Reducing post-harvest food losses through innovative collaboration: Insights from the Colombian and Mexican avocado supply

- chains,” *Journal of Cleaner Production*, vol. 199, pp. 1020–1034, 2018, doi: 10.1016/j.jclepro.2018.06.187.
- [20] United Nations, “The sustainable development goals report 2019,” *United Nations publication issued by the Department of Economic and Social Affairs*, p. 64, 2019.
- [21] M. del C. Alamar, N. Falagán, E. Aktas, and L. A. Terry, “Minimising food waste: a call for multidisciplinary research,” *Journal of the Science of Food and Agriculture*, 2018, doi: 10.1002/jsfa.8708.
- [22] C. Beretta, F. Stoessel, U. Baier, and S. Hellweg, “Quantifying food losses and the potential for reduction in Switzerland,” *Waste Management*, 2013, doi: 10.1016/j.wasman.2012.11.007.
- [23] “A systematic literature review of food sustainable supply chain management (FSSCM): building blocks and research trends | Emerald Insight.” Accessed: Jan. 01, 2024. [Online]. Available: <https://www.emerald.com/insight/content/doi/10.1108/TQM-10-2021-0300/full/html>
- [24] A. Guo, S. Bryngelsson, A. Strid, M. Bianchi, A. Winkvist, and E. Hallström, “Choice of health metrics for combined health and environmental assessment of foods and diets: A systematic review of methods,” *Journal of Cleaner Production*, vol. 365. 2022. doi: 10.1016/j.jclepro.2022.132622.
- [25] S. Ammirato, A. M. Felicetti, M. Ferrara, C. Raso, and A. Violi, “Collaborative Organization Models for Sustainable Development in the Agri-Food Sector,” *Sustainability*, vol. 13, no. 4, p. 2301, 2021, doi: 10.3390/su13042301.
- [26] M. J. Page *et al.*, “The PRISMA 2020 statement: an updated guideline for reporting systematic reviews,” *BMJ*, p. n71, Mar. 2021, doi: 10.1136/bmj.n71.
- [27] Y. Chiffolleau and T. Dourian, “Sustainable Food Supply Chains: Is Shortening the Answer? A Literature Review for a Research and Innovation Agenda,” *Sustainability*, vol. 12, no. 23, p. 9831, 2020, doi: 10.3390/su12239831.
- [28] L. Shamseer *et al.*, “Preferred reporting items for systematic review and meta-analysis protocols (PRISMA-P) 2015: elaboration and explanation.,” *BMJ*, vol. 349, pp. 1–25, Jan. 2015, doi: 10.1136/bmj.g7647.
- [29] G. Brunori and F. Galli, “Sustainability of local and global food chains: Introduction to the special issue,” *Sustainability (Switzerland)*, vol. 8, no. 8. 2016. doi: 10.3390/su8080765.
- [30] S. Ahmad and K. Wong, “A Comprehensive and Integrated Stochastic-Fuzzy Method for Sustainability Assessment in the Malaysian Food Manufacturing Industry,” *Sustainability*, vol. 11, no. 4, p. 948, Feb. 2019, doi: 10.3390/su11040948.
- [31] A. Bjorn *et al.*, “A comprehensive planetary boundary-based method for the nitrogen cycle in life cycle assessment: Development and application to a tomato production case study.” Accessed: Dec. 22, 2022. [Online]. Available: <https://reader.elsevier.com/reader/sd/pii/S0048969720303235?token=23A7616CCB8DC5C94FC35513641ABEC8A45499DEEE391B96DE8C5A582F8032C9E05525D2A11B997FEAA430419392E5A5&originRegion=eu-west-1&originCreation=20221222110904>
- [32] M. Kucukvar, N. C. Onat, G. M. Abdella, and O. Tatari, “Assessing regional and global environmental footprints and value added of the largest food producers in the world,” *Resources, Conservation and Recycling*, vol. 144. pp. 187–197, 2019. doi: 10.1016/j.resconrec.2019.01.048.
- [33] A. Avadí, P. Fréon, and J. Tam, “Coupled ecosystem/supply chain modelling of fish products from sea to shelf: The Peruvian anchoveta case,” *PLoS ONE*, vol. 9, no. 7. 2014. doi: 10.1371/journal.pone.0102057.

- [34] M. Al-Obadi, "Dairy Wastage Footprint Analysis: A Farm-to-Fork Life Cycle Approach Across Dairy Supply Chain.," *Proceedings of the International Conference on Industrial Engineering and Operations Management*. pp. 200–211, 2021. [Online]. Available: <https://www.scopus.com/inward/record.uri?eid=2-s2.0-85130250902&partnerID=40&md5=e23f93022cf47e97afeb4137dd99b90b>
- [35] T. Winkler and R. Aschemann, "Decreasing greenhouse gas emissions of meat products through food waste reduction. A framework for a sustainability assessment approach," *Food Waste Reduction and Valorisation: Sustainability Assessment and Policy Analysis*. 2017. doi: 10.1007/978-3-319-50088-1_4.
- [36] A. K. Farmery, C. Gardner, B. S. Green, S. Jennings, and R. A. Watson, "Domestic or imported? An assessment of carbon footprints and sustainability of seafood consumed in Australia," *Environmental Science and Policy*, vol. 54. pp. 35–43, 2015. doi: 10.1016/j.envsci.2015.06.007.
- [37] G. Garcia-Garcia, L. Azanedo, and S. Rahimifard, "Embedding sustainability analysis in new food product development," *Trends in Food Science and Technology*, vol. 108. pp. 236–244, 2021. doi: 10.1016/j.tifs.2020.12.018.
- [38] R. Stefanini and G. Vignali, "Environmental and economic sustainability assessment of an industry 4.0 application: the AGV implementation in a food industry," *International Journal of Advanced Manufacturing Technology*, vol. 120, no. 5–6. pp. 2937–2959, 2022. doi: 10.1007/s00170-022-08950-6.
- [39] Preethi, S. Kavitha, J. R. Banu, P. Arulazhagan, and M. Gunasekaran, "Environmental impacts and sustainability assessment of food loss and waste valorization: Value chain analysis of food consumption," *Food Waste to Valuable Resources: Applications and Management*. 2020. doi: 10.1016/B978-0-12-818353-3.00017-1.
- [40] M. Dreyer *et al.*, "Environmental life cycle assessment of yellow mealworm (*Tenebrio molitor*) production for human consumption in Austria – a comparison of mealworm and broiler as protein source," *International Journal of Life Cycle Assessment*, vol. 26, no. 11. pp. 2232–2247, 2021. doi: 10.1007/s11367-021-01980-4.
- [41] V. Uusitalo, A. Kuokkanen, K. Grönman, N. Ko, H. Mäkinen, and K. Koistinen, "Environmental sustainability assessment from planetary boundaries perspective – A case study of an organic sheep farm in Finland," *Science of the Total Environment*, vol. 687. pp. 168–176, 2019. doi: 10.1016/j.scitotenv.2019.06.120.
- [42] M. Cooreman-Algoed, L. Boone, S. E. Taelman, S. Van Hemelryck, A. Brunson, and J. Dewulf, "Impact of consumer behaviour on the environmental sustainability profile of food production and consumption chains – a case study on chicken meat," *Resources, Conservation and Recycling*, vol. 178. 2022. doi: 10.1016/j.resconrec.2021.106089.
- [43] S. Cristiano, H. Baarset, C. Bruckner, J. Johansen, and R. Pastres, "Innovative options for the reuse and valorisation of aquaculture sludge and fish mortalities: Sustainability evaluation through Life-Cycle Assessment," *Journal of Cleaner Production*, vol. 352. 2022. doi: 10.1016/j.jclepro.2022.131613.
- [44] S. Ahmad, K. Y. Wong, and R. Ahmad, "Life cycle assessment for food production and manufacturing: Recent trends, global applications and future prospects," vol. 34. pp. 49–57, 2019. doi: 10.1016/j.promfg.2019.06.113.
- [45] F. Ziegler *et al.*, "Local seal or imported meat? Sustainability evaluation of food choices in greenland, based on life cycle assessment," *Foods*, vol. 10, no. 6. 2021. doi: 10.3390/foods10061194.
- [46] G. Egilmez, M. Kucukvar, O. Tatari, and M. K. S. Bhutta, "Supply chain sustainability assessment of the U.S. food manufacturing sectors: A life cycle-based frontier approach," *Resources, Conservation and Recycling*, vol. 82, pp. 8–20, Jan. 2014, doi: 10.1016/j.resconrec.2013.10.008.

- [47] G. M. Abdella *et al.*, “Sustainability assessment and modeling based on supervised machine learning techniques: The case for food consumption,” *Journal of Cleaner Production*, vol. 251, p. 119661, Apr. 2020, doi: 10.1016/j.jclepro.2019.119661.
- [48] P. Bergström, C. Malefors, I. Strid, O. J. Hanssen, and M. Eriksson, “Sustainability assessment of food redistribution initiatives in Sweden,” *Resources*, vol. 9, no. 3. 2020. doi: 10.3390/resources9030027.
- [49] S. Rafiee, B. Khoshnevisan, I. Mohammadi, M. Aghbashlo, H. mousazadeh, and S. Clark, “Sustainability evaluation of pasteurized milk production with a life cycle assessment approach: An Iranian case study,” *Science of the Total Environment*, vol. 562. pp. 614–627, 2016. doi: 10.1016/j.scitotenv.2016.04.070.
- [50] K. Shahzad, M. Rehan, M. I. Rashid, N. Ali, A. S. Summan, and I. M. I. Ismail, “Sustainability evaluation of polyhydroxyalkanoate production from slaughterhouse residues utilising emergy accounting,” *Polymers*, vol. 14, no. 1. 2022. doi: 10.3390/polym14010118.
- [51] N. Yakovleva, J. Sarkis, and T. W. Sloan, “Sustainability indicators for the food supply chain,” in *Environmental Assessment and Management in the Food Industry*, Elsevier, 2010, pp. 297–329. doi: 10.1533/9780857090225.3.297.
- [52] J. Schwarz, M. Schuster, B. Annaert, M. Maertens, Erik Mathijs, and E. Mathijs, “Sustainability of global and local food value chains. An empirical comparison of Peruvian and Belgian asparagus,” Mar. 2016.
- [53] S. M. Ioannidou *et al.*, “Sustainable production of bio-based chemicals and polymers via integrated biomass refining and bioprocessing in a circular bioeconomy context,” *Bioresour Technol*, vol. 307. 2020. doi: 10.1016/j.biortech.2020.123093.
- [54] H. Rohn, M. Lukas, K. Bienge, J. Ansorge, and C. Liedtke, “The hot spot analysis: Utilization as customized management tool towards sustainable value chains of companies in the food sector,” *Agris On-line Papers in Economics and Informatics*, vol. 6, no. 4. pp. 133–143, 2014.
- [55] A. Dobon *et al.*, “The sustainability of communicative packaging concepts in the food supply chain. A case study: Part 2. Life cycle costing and sustainability assessment,” *International Journal of Life Cycle Assessment*, vol. 16, no. 6. pp. 537–547, 2011. doi: 10.1007/s11367-011-0291-9.
- [56] A. Melkonyan, K. Krumme, T. Gruchmann, and G. De La Torre, “Sustainability assessment and climate change resilience in food production and supply,” *Energy Procedia*, vol. 123. pp. 131–138, 2017. doi: 10.1016/j.egypro.2017.07.236.
- [57] A. Melkonyan, T. Gruchmann, F. Lohmar, V. Kamath, and S. Spinler, “Sustainability assessment of last-mile logistics and distribution strategies: The case of local food networks,” *International Journal of Production Economics*, vol. 228. 2020. doi: 10.1016/j.ijpe.2020.107746.
- [58] G. Brunori *et al.*, “Are local food chains more sustainable than global food chains? Considerations for Assessment,” *Sustainability (Switzerland)*, vol. 8, no. 5. 2016. doi: 10.3390/su8050449.
- [59] C. Peano, N. Tecco, E. Dansero, V. Girgenti, and F. Sottile, “Evaluating the sustainability in complex agri-food systems: The SAEMETH framework,” *Sustainability (Switzerland)*, vol. 7, no. 6. pp. 6721–6741, 2015. doi: 10.3390/su7066721.
- [60] A. M. Gómez-Trujillo and I. C. A. Rendón, “International presence and sustainability in emerging markets: Nutresa Group towards a global leadership; [Presencia internacional y sostenibilidad en mercados emergentes: Grupo Nutresa hacia un liderazgo global],” *Produccion y Limpia*, vol. 14, no. 1. pp. 77–93, 2019. doi: 10.22507/pml.v14n1a4.
- [61] A. Doernberg, A. Piorr, I. Zasada, D. Wascher, and U. Schmutz, “Sustainability assessment of short food supply chains (SFSC): developing and testing a rapid

- assessment tool in one African and three European city regions,” *Agriculture and Human Values*, vol. 39, no. 3. pp. 885–904, 2022. doi: 10.1007/s10460-021-10288-w.
- [62] A. Woodhouse, J. Davis, C. Pénicaud, and K. Östergren, “Sustainability checklist in support of the design of food processing,” *Sustainable Production and Consumption*, vol. 16. pp. 110–120, 2018. doi: 10.1016/j.spc.2018.06.008.
- [63] D. Marino, L. Mastronardi, A. Giannelli, V. Giaccio, and G. Mazzocchi, “Territorialisation dynamics for Italian farms adhering to Alternative Food Networks,” *Bulletin of Geography. Socio-economic Series*, no. 40, Art. no. 40, Jun. 2018, doi: 10.2478/bog-2018-0018.
- [64] E. Bottani, M. C. Gentilotti, and M. Rinaldi, “A fuzzy logic-based tool for the assessment of corporate sustainability: A case study in the food machinery industry,” *Sustainability (Switzerland)*, vol. 9, no. 4. 2017. doi: 10.3390/su9040583.
- [65] E. Sharifi, S. H. Amin, and L. Fang, “A new fuzzy group decision-making approach for evaluating sustainability of food supply chains,” *IISE Annual Conference and Expo 2021*. pp. 199–204, 2021. [Online]. Available: <https://www.scopus.com/inward/record.uri?eid=2-s2.0-85120932241&partnerID=40&md5=ead427d0f02beb3529572821435d8c71>
- [66] M. Yani *et al.*, “An Adaptive Fuzzy Multi-Criteria Model for Sustainability Assessment of Sugarcane Agroindustry Supply Chain,” *IEEE Access*, vol. 10. pp. 5497–5517, 2022. doi: 10.1109/ACCESS.2022.3140519.
- [67] V. Sridharan and M. Suresh, “Environmental sustainability assessment using multigrade fuzzy-A case of two Indian colleges,” *2016 IEEE International Conference on Computational Intelligence and Computing Research, ICCIC 2016*. 2016. doi: 10.1109/ICCIC.2016.7919594.
- [68] Mukesh Kumar, M. Sharma, R. D. Raut, S. K. Mangla, and Vikas Kumar Choubey, “Performance assessment of circular driven sustainable agri-food supply chain towards achieving sustainable consumption and production,” *Journal of Cleaner Production*, vol. 372, pp. 133698–133698, Oct. 2022, doi: 10.1016/j.jclepro.2022.133698.
- [69] C J Siddegowda and A. Jayanthila Devi, “A Study on the Role of Precision Agriculture in Agro-Industry,” vol. 5, no. 2, pp. 57–67, Sep. 2021, doi: 10.47992/ijaeml.2581.7000.0103.
- [70] A. Kumar, S. K. Mangla, and P. Kumar, “An integrated literature review on sustainable food supply chains: Exploring research themes and future directions,” *Science of the Total Environment*, vol. 821. 2022. doi: 10.1016/j.scitotenv.2022.153411.
- [71] W. A. P. Dania, K. Xing, and Y. Amer, “Collaboration and Sustainable Agri-Food Supply Chain: A Literature Review,” vol. 58, p. 02004, Jan. 2016, doi: 10.1051/mateconf/20165802004.
- [72] R. Küchler and C. Herzig, “Connectivity is key: holistic sustainability assessment and reporting from the perspective of food manufacturers,” *British Food Journal*, vol. 123, no. 9. pp. 3154–3171, 2021. doi: 10.1108/BFJ-03-2021-0317.
- [73] C. Moreno-Miranda and L. Dries, “Integrating coordination mechanisms in the sustainability assessment of agri-food chains: From a structured literature review to a comprehensive framework,” *Ecological Economics*, vol. 192. 2022. doi: 10.1016/j.ecolecon.2021.107265.
- [74] A. M. Faus, A. Moragues-Faus, and A. Marceau, “Measuring Progress in Sustainable Food Cities: An Indicators Toolbox for Action,” *Sustainability*, vol. 11, no. 1, p. 45, Dec. 2018, doi: 10.3390/sul11010045.
- [75] E. Desiderio, L. García-Herrero, D. Hall, A. Segrè, and M. Vittuari, “Social sustainability tools and indicators for the food supply chain: A systematic literature review,”

- Sustainable Production and Consumption*, vol. 30. pp. 527–540, 2022. doi: 10.1016/j.spc.2021.12.015.
- [76] Shamraiz Ahmad, Kuan Yew Wong, and Shahid Ikramullah Butt, “Status of sustainable manufacturing practices: literature review and trends of triple bottom-line-based sustainability assessment methodologies,” *Environmental Science and Pollution Research*, Jul. 2022, doi: 10.1007/s11356-022-22172-z.
- [77] J. G. A. J. van der Vorst, L. Peeters, and J. M. Bloemhof, “Sustainability Assessment Framework for Food Supply Chain Logistics: Empirical Findings from Dutch Food Industry,” *International Journal on Food System Dynamics*, vol. 4, no. 2. pp. 130–139, 2013. doi: 10.18461/ijfsd.v4i2.424.
- [78] H. El Bilali, C. Strassner, and T. Ben Hassen, “Sustainable agri-food systems: Environment, economy, society, and policy,” *Sustainability (Switzerland)*, vol. 13, no. 11. 2021. doi: 10.3390/su13116260.
- [79] E. Slätmo, Elin Slätmo, K. Fischer, and E. Rööf, “The Framing of Sustainability in Sustainability Assessment Frameworks for Agriculture,” *Sociologia Ruralis*, vol. 57, no. 3, pp. 378–395, Jul. 2017, doi: 10.1111/soru.12156.
- [80] C. Silvestri, L. Silvestri, M. Piccarozzi, and Alessandro Ruggieri, “Toward a framework for selecting indicators of measuring sustainability and circular economy in the agri-food sector: a systematic literature review,” *International Journal of Life Cycle Assessment*, Mar. 2022, doi: 10.1007/s11367-022-02032-1.
- [81] F. Galli *et al.*, “Sustainability assessment of food supply chains: an application to local and global bread in Italy,” *Agricultural and Food Economics*, vol. 3, no. 1. 2015. doi: 10.1186/s40100-015-0039-0.
- [82] V. León Bravo, A. Moretto, and F. Caniato, “A roadmap for sustainability assessment in the food supply chain,” *British Food Journal*, vol. 123, no. 13. pp. 199–220, 2021. doi: 10.1108/BFJ-04-2020-0293.
- [83] A. Tunı and A. Rentizelas, “Improving environmental sustainability in agri-food supply chains: Evidence from an eco-intensity-based method application,” *Cleaner Logistics and Supply Chain*, vol. 5. 2022. doi: 10.1016/j.clscn.2022.100081.
- [84] V. León-Bravo, F. Caniato, and M. Caridi, “Sustainability assessment in the food supply chain: study of a certified product in Italy,” *Production Planning and Control*, vol. 32, no. 7. pp. 567–584, 2021. doi: 10.1080/09537287.2020.1744761.
- [85] N. P. Springer *et al.*, “Sustainable sourcing of global agricultural raw materials: Assessing gaps in key impact and vulnerability issues and indicators,” *PLoS ONE*, vol. 10, no. 6. 2015. doi: 10.1371/journal.pone.0128752.
- [86] A. Avadí and P. Fréon, “A set of sustainability performance indicators for seafood: Direct human consumption products from Peruvian anchoveta fisheries and freshwater aquaculture,” *Ecological Indicators*, 2015, doi: 10.1016/j.ecolind.2014.09.006.
- [87] Y. Leeben, P. Soni, and G. P. Shivakoti, “Indicators of sustainable development for assessing performance of pineapple canneries: Conceptual framework and application,” *Journal of Food, Agriculture and Environment*, vol. 11, no. 2. pp. 100–109, 2013.
- [88] A. Malak-Rawlikowska *et al.*, “Measuring the economic, environmental, and social sustainability of short food supply chains,” *Sustainability (Switzerland)*, vol. 11, no. 15. 2019. doi: 10.3390/su11154004.
- [89] M. E. Ruiz Molina, S. Belda-Miquel, A. Hytti, and I. Gil-Saura, “Addressing sustainable food management in hotels: proposing a framework and examining hotel groups,” *British Food Journal*, vol. 124, no. 2. pp. 462–492, 2022. doi: 10.1108/BFJ-12-2020-1171.
- [90] S. A. Sarkodie, V. Strezov, H. Weldekidan, E. F. Asamoah, P. A. Owusu, and I. N. Y. Doyi, “Environmental sustainability assessment using dynamic Autoregressive-Distributed Lag simulations—Nexus between greenhouse gas emissions, biomass

- energy, food and economic growth,” *Science of the Total Environment*, vol. 668. pp. 318–332, 2019. doi: 10.1016/j.scitotenv.2019.02.432.
- [91] L. Mastronardi, D. Marino, V. Giaccio, A. Giannelli, M. Palmieri, and G. Mazzocchi, “Analyzing Alternative Food Networks sustainability in Italy: a proposal for an assessment framework,” *Agricultural and Food Economics*, vol. 7, no. 1. 2019. doi: 10.1186/s40100-019-0142-8.
- [92] A. Bonanno *et al.*, “Improvement of oxidative status, milk and cheese production, and food sustainability indexes by addition of durum wheat bran to dairy cows’ diet,” *Animals*, vol. 9, no. 9. 2019. doi: 10.3390/ani9090698.
- [93] T. Stillitano *et al.*, “An economic sustainability assessment of ‘Fichi di Cosenza’ PDO production compared with other profitable permanent crops,” *Acta Horticulturae*, vol. 2017, no. 1173. pp. 395–400, 2017. doi: 10.17660/ActaHortic.2017.1173.68.
- [94] Mariany Costa Deprá, Rosangela Rodrigues Dias, Leila Queiroz Zepka, and Eduardo Jacob-Lopes, “Building cleaner production: How to anchor sustainability in the food production chain?,” *Environmental advances*, vol. 9, pp. 100295–100295, Sep. 2022, doi: 10.1016/j.envadv.2022.100295.
- [95] S. Schmidheiny, R. Chase, and L. DeSimone, *Signals of change : business progress towards sustainable development*. 1997. Accessed: Jan. 02, 2024. [Online]. Available: <https://portals.iucn.org/library/node/22701>
- [96] G. Halkos and S. Nomikos, “Corporate social responsibility: Trends in global reporting initiative standards,” *Economic Analysis and Policy*, vol. 69, pp. 106–117, Mar. 2021, doi: 10.1016/j.eap.2020.11.008.
- [97] R. K. Singh, H. R. Murty, S. K. Gupta, and A. K. Dikshit, “An overview of sustainability assessment methodologies,” Apr. 2012, Accessed: Jan. 01, 2024. [Online]. Available: <https://www.sciencedirect.com/science/article/pii/S1470160X11000240>
- [98] E. Širá, R. Vavrek, I. Kravčáková Vozárová, and R. Kotulič, “Knowledge Economy Indicators and Their Impact on the Sustainable Competitiveness of the EU Countries,” *Sustainability*, vol. 12, no. 10, Art. no. 10, Jan. 2020, doi: 10.3390/su12104172.
- [99] D. Meadows, “Indicators and Information Systems for Sustainable Development,” in *The Earthscan Reader in Sustainable Cities*, 1st ed., London: Routledge, 2021, pp. 364–393. doi: 10.4324/9781315800462-21.
- [100] S. Damkjaer and R. Taylor, “The measurement of water scarcity: Defining a meaningful indicator,” *Ambio*, vol. 46, no. 5, pp. 513–531, Sep. 2017, doi: 10.1007/s13280-017-0912-z.
- [101] A. Warhurst, “Sustainability Indicators and Sustainability Performance Management”.
- [102] J. Bebbington, J. Brown, and B. Frame, “Accounting technologies and sustainability assessment models,” *Ecological Economics*, vol. 61, no. 2, pp. 224–236, Mar. 2007, doi: 10.1016/j.ecolecon.2006.10.021.
- [103] B. Ness, E. Urbel-Piirsalu, S. Anderberg, and L. Olsson, “Categorising tools for sustainability assessment,” *Ecological Economics*, vol. 60, no. 3, pp. 498–508, Jan. 2007, doi: 10.1016/j.ecolecon.2006.07.023.
- [104] “The Product Carbon Footprint Guideline for the Chemical Industry.” Nov. 2022. [Online]. Available: <https://www.tfs-initiative.com/>
- [105] Florian Berg, Julian F Köml;bel, Julian F Köml;bel, and Roberto Rigobon, “Aggregate Confusion: The Divergence of ESG Rating,” *Review of Finance*, May 2022, doi: 10.1093/rof/rfac033.
- [106] “Timeline and History of ESG Investing, Rules and Practices,” Sustainability and ESG. Accessed: Jan. 01, 2024. [Online]. Available: <https://www.techtarget.com/sustainability/feature/A-timeline-and-history-of-ESG-investing-rules-and-practices>

- [107] A. Edmans, “The End of ESG.” 2023. Accessed: Jan. 01, 2024. [Online]. Available: https://papers.ssrn.com/sol3/papers.cfm?abstract_id=4221990
- [108] B. Baue, “ESG or Sustainability: You Choose | Impact Entrepreneur.” Accessed: Jan. 01, 2024. [Online]. Available: <https://impactentrepreneur.com/esg-or-sustainability-you-choose/>
- [109] Joanna Krasodomska, E. Zarzycka, and Paweł Zieniuk, “Voluntary sustainability reporting assurance in the European Union before the advent of the corporate sustainability reporting directive: The country and firm-level impact of Sustainable Development Goals,” *Sustainable Development*, 2023, doi: 10.1002/sd.2744.
- [110] *DIRECTIVE OF THE EUROPEAN PARLIAMENT AND OF THE COUNCIL amending Directive 2013/34/EU, Directive 2004/109/EC, Directive 2006/43/EC and Regulation (EU) No 537/2014, as regards corporate sustainability reporting.*
- [111] L. Reeder, *Guide to Green Building Rating Systems: Understanding LEED, Green Globes, Energy Star, the National Green Building Standard, and More*, 1st ed. Wiley, 2010. doi: 10.1002/9781118259894.
- [112] SJ Kühne, E Reijnen, L Vogt Laasner, and M Baumgartner, “Can carbon labels encourage green food choices?,” *Frontiers in psychology*, vol. 13, Jan. 2023, doi: <https://doi.org/10.3389/fpsyg.2022.902869>.
- [113] M. Li *et al.*, “Global food-miles account for nearly 20 % of total food-systems emissions,” *Nature food*, doi: 10.1038/s43016-022-00531-w.
- [114] F. Sgarbossa and I. Russo, “A proactive model in sustainable food supply chain: Insight from a case study,” *International Journal of Production Economics*, 2017, doi: 10.1016/j.ijpe.2016.07.022.
- [115] K. C. Krishna Bahadur, I. Haque, A. F. Legwegoh, and E. D. G. Fraser, “Strategies to reduce food loss in the global south,” *Sustainability (Switzerland)*, 2016, doi: 10.3390/su8070595.
- [116] B. Notarnicola, K. Hayashi, M. A. Curran, and D. Huisingh, “Progress in working towards a more sustainable agri-food industry,” *Journal of Cleaner Production*, 2012, doi: 10.1016/j.jclepro.2012.02.007.
- [117] J. H. Trienekens, P. M. Wognum, A. J. M. Beulens, and J. G. A. J. Van Der Vorst, “Transparency in complex dynamic food supply chains,” *Advanced Engineering Informatics*, vol. 26, no. 1, pp. 55–65, 2012, doi: 10.1016/j.aei.2011.07.007.
- [118] J. B. E. M. Steenkamp, “Conceptual model of the quality perception process,” *Journal of Business Research*, 1990, doi: 10.1016/0148-2963(90)90019-A.
- [119] G. Migliore, G. Schifani, and L. Cembalo, “Opening the black box of food quality in the short supply chain: Effects of conventions of quality on consumer choice,” *Food Quality and Preference*, vol. 39, pp. 141–146, 2015, doi: 10.1016/j.foodqual.2014.07.006.
- [120] C. Chen, J. Zhang, and T. Delaurentis, “Quality control in food supply chain management: An analytical model and case study of the adulterated milk incident in China,” *International Journal of Production Economics*, vol. 152, pp. 188–199, 2014, doi: 10.1016/j.ijpe.2013.12.016.
- [121] FAO, “Food wastage footprint,” in *Fao, un*, 2013.
- [122] B. Lipinski, C. Hanson, J. Lomax, L. Kitinoja, R. Waite, and T. Searchinger, “Reducing food loss and waste. Working paper, installment 2 of creating a sustainable food future.,” 2016.
- [123] C. Willersinn, G. Mack, P. Mouron, A. Keiser, and M. Siegrist, “Quantity and quality of food losses along the Swiss potato supply chain: Stepwise investigation and the influence of quality standards on losses,” *Waste Management*, vol. 46, pp. 120–132, 2015, doi: 10.1016/j.wasman.2015.08.033.

- [124] B. Devin and C. Richards, "Food waste, power, and corporate social responsibility in the Australian food supply chain," *Journal of Business Ethics*, vol. 150, no. 1, pp. 199–210, 2018, doi: 10.1007/s10551-016-3181-z.
- [125] A. Patel and D. G. Woodward, "Supermarkets and the organic food supply chain: The potential for waste generation and its mitigation." 2007. doi: 10.1504/IJGENVI.2007.012076.
- [126] S. S. Davey and C. Richards, "Supermarkets and private standards: Unintended consequences of the audit ritual," *Agriculture and Human Values*, 2013, doi: 10.1007/s10460-012-9414-6.
- [127] C. Richards, H. Bjørkhaug, G. Lawrence, and E. Hickman, "Retailer-driven agricultural restructuring-Australia, the UK and Norway in comparison," *Agriculture and Human Values*, 2013, doi: 10.1007/s10460-012-9408-4.
- [128] J. Liu, J. Lundqvist, J. Weinberg, and J. Gustafsson, "Food losses and waste in China and their implication for water and land," *Environmental Science and Technology*, 2013, doi: 10.1021/es401426b.
- [129] European Commission and T. Report, "Preparatory study on food waste across EU 27," in *October*, 2010.
- [130] K. Verghese, H. Lewis, S. Lockrey, and H. Williams, "Packaging's role in minimizing food loss and waste across the supply chain," *Packaging Technology and Science*, 2015, doi: 10.1002/pts.2127.
- [131] K. Liljestrand, "Logistics solutions for reducing food waste," *International Journal of Physical Distribution and Logistics Management*, 2017, doi: 10.1108/IJPDLM-03-2016-0085.
- [132] J. K. Heising, G. D. H. Claassen, and M. Dekker, "Options for reducing food waste by quality-controlled logistics using intelligent packaging along the supply chain," *Food Additives and Contaminants - Part A Chemistry, Analysis, Control, Exposure and Risk Assessment*, vol. 34, no. 10, pp. 1672–1680, 2017, doi: 10.1080/19440049.2017.1315776.
- [133] F. Lomiri and S. Cappello, "Stuffed and starved: The hidden battle for the world food system," *Development*, 2008, doi: 10.1057/dev.2008.63.
- [134] D. Gunasekera, "Food production: Cut food waste to help feed world." 2015. doi: 10.1038/524415a.
- [135] K. D. Hall, J. Guo, M. Dore, and C. C. Chow, "The progressive increase of food waste in America and its environmental impact," *PLoS ONE*, 2009, doi: 10.1371/journal.pone.0007940.
- [136] FAO, "State of Food and Agriculture 2010-2011," 2011.
- [137] L. Xue *et al.*, "Missing food, missing data? A critical review of global food losses and food waste data," *Environmental Science and Technology*, 2017, doi: 10.1021/acs.est.7b00401.
- [138] "Reducing food's environmental impacts through producers and consumers | Science." Accessed: Jan. 02, 2024. [Online]. Available: <https://www.science.org/doi/10.1126/science.aag0216>
- [139] C. Cederberg and U. Sonesson, *Global food losses and food waste: extent, causes and prevention; study conducted for the International Congress Save Food! at Interpack 2011, [16 - 17 May], Düsseldorf, Germany*. Rome: Food and Agriculture Organization of the United Nations, 2011.
- [140] T. Wan, D. Wan, L. Wang, Y. Dou, X. Sun, and J. Hu, "Assessment of environmental benefits from phasing out CFCs in refrigerator industry of China," *Beijing Daxue Xuebao (Ziran Kexue Ban)/Acta Scientiarum Naturalium Universitatis Pekinensis*, 2011.

- [141] H. Zhao, S. Liu, C. Tian, G. Yan, and D. Wang, "An overview of current status of cold chain in China," *International Journal of Refrigeration*, vol. 88, pp. 483–495, 2018, doi: 10.1016/j.ijrefrig.2018.02.024.
- [142] O. I. Aruoma, "The impact of food regulation on the food supply chain," *Toxicology*, 2006, doi: 10.1016/j.tox.2005.12.024.
- [143] T. Bosona and G. Gebresenbet, "Food traceability as an integral part of logistics management in food and agricultural supply chain." 2013. doi: 10.1016/j.foodcont.2013.02.004.
- [144] M. Vanderroost, P. Ragaert, F. Devlieghere, and B. De Meulenaer, "Intelligent food packaging: The next generation." 2014. doi: 10.1016/j.tifs.2014.06.009.
- [145] R. Akkerman, P. Farahani, and M. Grunow, "Quality, safety and sustainability in food distribution: A review of quantitative operations management approaches and challenges," *OR Spectrum*, 2010, doi: 10.1007/s00291-010-0223-2.
- [146] M. Soysal, J. M. Bloemhof-Ruwaard, and J. G. A. J. Van Der Vorst, "Modelling food logistics networks with emission considerations: The case of an international beef supply chain," *International Journal of Production Economics*, vol. 152, pp. 57–70, 2014, doi: 10.1016/j.ijpe.2013.12.012.
- [147] P. Beske-Janssen, M. P. Johnson, and S. Schaltegger, "20 years of performance measurement in sustainable supply chain management – what has been achieved?" 2015. doi: 10.1108/SCM-06-2015-0216.
- [148] M. Z. Hauschild, R. K. Rosenbaum, and S. I. Olsen, Eds., *Life Cycle Assessment: Theory and Practice*. Cham: Springer International Publishing, 2018. doi: 10.1007/978-3-319-56475-3.
- [149] R. Kaipia, I. Dukovska-Popovska, and L. Loikkanen, "Creating sustainable fresh food supply chains through waste reduction," *International Journal of Physical Distribution and Logistics Management*, 2013, doi: 10.1108/IJPDLM-11-2011-0200.
- [150] R. Manzini and R. Accorsi, "The new conceptual framework for food supply chain assessment," *Journal of Food Engineering*, vol. 115, no. 2, pp. 251–263, 2013, doi: 10.1016/j.jfoodeng.2012.10.026.
- [151] M. Fritz and G. Schiefer, "Food chain management for sustainable food system development: A European research Agenda," *Agribusiness*, 2008, doi: 10.1002/agr.20172.
- [152] M. Bourlakis, G. Maglaras, D. Gallear, and C. Fotopoulos, "Examining sustainability performance in the supply chain: The case of the Greek dairy sector," *Industrial Marketing Management*, 2014, doi: 10.1016/j.indmarman.2013.08.002.
- [153] D. Kumar and Z. Rahman, "Sustainability adoption through buyer supplier relationship across supply chain: A literature review and conceptual framework," *International Strategic Management Review*, 2015, doi: 10.1016/j.ism.2015.04.002.
- [154] T. M. Stevens, N. Aarts, C. J. A. M. Termeer, and A. Dewulf, "Social media as a new playing field for the governance of agro-food sustainability." 2016. doi: 10.1016/j.cosust.2015.11.010.
- [155] S. K. Mangla, S. Luthra, N. Rich, D. Kumar, N. P. Rana, and Y. K. Dwivedi, "Enablers to implement sustainable initiatives in agri-food supply chains," *International Journal of Production Economics*, vol. 203, no. April 2017, pp. 379–393, 2018, doi: 10.1016/j.ijpe.2018.07.012.
- [156] H. Xiaohong Chen, *Approaches to Quantitative Research: A Guide for Dissertation Students : A Guide for Dissertation Students*. Accessed: Jan. 06, 2024. [Online]. Available: <https://web-p-ebcsohost-com.resursi.rtu.lv/ehost/ebookviewer/ebook/ZTAwMhH3d19fMTAwOTk2M19fQU41?sid=bd3085f2-f73c-4d16-b894-ccf7b684eafe@redis&vid=0&format=EB&rid=1>

- [157] “SPIRIT 2013 explanation and elaboration: guidance for protocols of clinical trials | The BMJ.” Accessed: Jan. 11, 2024. [Online]. Available: <https://www.bmj.com/content/346/bmj.e7586>
- [158] Institute of Medicine (US) Committee on Standards for Systematic Reviews of Comparative Effectiveness Research, *Finding What Works in Health Care: Standards for Systematic Reviews*. Washington (DC): National Academies Press (US), 2011. Accessed: Jan. 11, 2024. [Online]. Available: <http://www.ncbi.nlm.nih.gov/books/NBK209518/>
- [159] H. Buxel, G. Esenduran, and S. Griffin, “Strategic sustainability: Creating business value with life cycle analysis,” *Business Horizons*, vol. 58, no. 1, pp. 109–122, Jan. 2015, doi: 10.1016/j.bushor.2014.09.004.
- [160] G. Rebitzer, T. Ekvall, R. Frischknecht, D. Hunkeler, and G. Norris, “Life cycle assessment part 1: framework, goal and scope definition, inventory analysis, and applications.” Accessed: Dec. 26, 2023. [Online]. Available: <https://pubmed.ncbi.nlm.nih.gov/15051246/>
- [161] I. Bartolozzi, F. Rizzi, and M. Frey, “Are district heating systems and renewable energy sources always an environmental win-win solution? A life cycle assessment case study in Tuscany, Italy.” 2017. doi: 10.1016/j.rser.2017.05.231.
- [162] O. Jolliet *et al.*, “IMPACT 2002+: A new life cycle impact assessment methodology.” 2003. doi: 10.1007/BF02978505.
- [163] S. Humbert, A. D. Schryver, X. Bengoa, M. Margni, and O. Jolliet, “IMPACT 2002 + : User guide,” vol. 21, p. 42, 2002.
- [164] S. Hellweg, E. Benetto, M. A. J. Huijbregts, F. Veronesi, and R. Wood, “Life-cycle assessment to guide solutions for the triple planetary crisis,” *Nat Rev Earth Environ*, vol. 4, no. 7, Art. no. 7, Jul. 2023, doi: 10.1038/s43017-023-00449-2.
- [165] A. Arias, G. Feijoo, and M. T. Moreira, “New Environmental Approach Based on a Combination of Planetary Boundaries and Life Cycle Assessment in the Wood-Based Bioadhesive Market,” *ACS Sustainable Chem. Eng.*, vol. 10, no. 34, pp. 11257–11272, Aug. 2022, doi: 10.1021/acssuschemeng.2c03058.
- [166] Samuel B. Perez-Vega, “Food processing and value generation align with nutrition and current environmental planetary boundaries,” *Sustainable Production and Consumption*, vol. 33, pp. 964–977, Aug. 2022, doi: 10.1016/j.spc.2022.08.022.
- [167] European Commission. Joint Research Centre. Institute for Environment and Sustainability., *Evaluation of weighting methods for measuring the EU-27 overall environmental impact*. LU: Publications Office, 2011. Accessed: Jan. 02, 2024. [Online]. Available: <https://data.europa.eu/doi/10.2788/88465>
- [168] X. Bai *et al.*, “Translating Earth system boundaries for cities and businesses,” *Nat Sustain*, Jan. 2024, doi: 10.1038/s41893-023-01255-w.
- [169] V. Martinez-Sanchez, M. A. Kromann, and T. F. Astrup, “Life cycle costing of waste management systems: Overview, calculation principles and case studies,” *Waste Management*, vol. 36, pp. 343–355, Feb. 2015, doi: 10.1016/j.wasman.2014.10.033.
- [170] A. Ciroth, G. Huppes, W. Klopffer, I. Rudenauer, B. Steen, and T. Swarr, “Environmental life cycle costing,” in *SETAC*, D. Hunkeler, K. Lichtenvort, and G. Rebitzer, Eds., New York, 2008.
- [171] A. Ciroth, J. Hildenbrand, and B. Steen, “Life Cycle Costing,” in *Sustainability Assessment of Renewables-Based Products*, 1st ed., J. Dewulf, S. De Meester, and R. A. F. Alvarenga, Eds., Wiley, 2015, pp. 215–228. doi: 10.1002/9781118933916.ch14.
- [172] R. Heijungs, E. Settanni, and J. Guinée, “Toward a computational structure for life cycle sustainability analysis: unifying LCA and LCC,” *Int J Life Cycle Assess*, vol. 18, no. 9, pp. 1722–1733, Nov. 2013, doi: 10.1007/s11367-012-0461-4.

- [173] International Standard Organization, *ISO 14040 International Standard Environmental Management - Life Cycle Assessment - Principles and Framework*, 2006. Accessed: Jan. 06, 2024. [Online]. Available: <https://www.iso.org/standard/37456.html>
- [174] International Standard Organization, *ISO 14044. Environmental management — Life cycle assessment — Requirements and guidelines*, 2006.
- [175] T. E. Swarr *et al.*, “Environmental life-cycle costing: a code of practice,” *Int J Life Cycle Assess*, vol. 16, no. 5, pp. 389–391, Jun. 2011, doi: 10.1007/s11367-011-0287-5.
- [176] F. De Menna, J. Dietershagen, Marion Loubiere, M. Loubiere, Matteo Vittuari, and M. Vittuari, “Life cycle costing of food waste: A review of methodological approaches,” *Waste Management*, vol. 73, pp. 1–13, Mar. 2018, doi: 10.1016/j.wasman.2017.12.032.
- [177] G. Huppes, M. Van Rooijen, R. Kleijn, A. De Koning, and L. Van Oers, “Report of a project commissioned by the Ministry of VROM-DGM for the RIVM Expertise Centre LCA,” Ministry of VROM-DGM, 2004.
- [178] G. National and H. Pillars, *Biofuels for a more sustainable future*. 2020.
- [179] A. Mazzi, “Introduction. Life cycle thinking,” in *Life cycle sustainability assessment for decision-making*, J. Ren and S. Toniolo, Eds., Elsevier Ltd, 2020, pp. 1–4.
- [180] L. C. Dreyer, M. Z. Hauschild, and J. Schierbeck, “A framework for social life cycle impact assessment,” *International Journal of Life Cycle Assessment*, 2006, doi: 10.1065/lca2005.08.223.
- [181] A. Lehmann, D. Russi, A. Bala, M. Finkbeiner, and P. Fullana-i-Palmer, “Integration of social aspects in decision support, based on life cycle thinking,” *Sustainability*, 2011, doi: 10.3390/su3040562.
- [182] N. Iofrida, A. Strano, G. Gulisano, and A. I. De Luca, “Why social life cycle assessment is struggling in development?,” *Int J Life Cycle Assess*, vol. 23, no. 2, pp. 201–203, Feb. 2018, doi: 10.1007/s11367-017-1381-0.
- [183] UNEP Setac Life Cycle Initiative, “Guidelines for social life cycle assessment of products and organizations 2020,” *Management*, vol. 15, no. 2, 2020, [Online]. Available: http://www.unep.fr/shared/publications/pdf/DTIx1164xPA-guidelines_sLCA.pdf
- [184] R. Lin, Y. Man, and J. Ren, “Chapter 8 - Framework of life cycle sustainability assessment,” in *Life Cycle Sustainability Assessment for Decision-Making*, J. Ren and S. Toniolo, Eds., Elsevier, 2020, pp. 155–173. doi: 10.1016/B978-0-12-818355-7.00008-7.
- [185] U. Schenker *et al.*, “Handbook for product social impact assessment. 2020,” no. November, 2020, doi: 10.13140/RG.2.2.33455.79523.
- [186] International EPD System, *Product Category Rules (PCR) for Social Product Declarations (SPD)*, SPD-PCR 2023:01, Oct. 30, 2023. [Online]. Available: <https://www.datocms-assets.com/37502/1698661714-spd-pcr-2023-01-rolling-stock-v1-0-0.pdf>
- [187] UNEP, One Planet Network, New Earth, and European Commission, “Shout it out: Communicating products’ social impacts a white paper of the one planet network consumer information programme,” 2018. [Online]. Available: http://www.oneplanetnetwork.org/sites/default/files/white_paper_-_communicating_products_social_impacts_cisep_2018.pdf %0Ahttps://www.international-climate-initiative.com/fileadmin/Dokumente/2018/20181023_White_Paper_-_Communicating_Products__Social_Impac
- [188] WBCSD, “Sustainable consumption facts and trends from a business perspective,” World Business Council for Sustainable Development, 2008. [Online]. Available: <https://docs.wbcsd.org/2008/11/SustainableConsumptionFactsAndTrends.pdf>

- [189] K. Rennert *et al.*, “Comprehensive evidence implies a higher social cost of CO₂,” *Nature*, vol. 610, no. 7933, pp. 687–692, Oct. 2022, doi: 10.1038/s41586-022-05224-9.
- [190] S. Zanoni *et al.*, “Improving Cold Chain Energy Efficiency: EU H2020 project for facilitating energy efficiency improvements in SMEs of the food and beverage cold chains,” *Refrigeration Science and Technology*, vol. 2020-Augus, pp. 361–369, 2020, doi: 10.18462/iir.iccc.2020.292878.
- [191] “Combining Life Cycle Assessment and Manufacturing System Simulation: Evaluating Dynamic Impacts from Renewable Energy Supply on Product-Specific Environmental Footprints | International Journal of Precision Engineering and Manufacturing-Green Technology.” Accessed: Dec. 26, 2023. [Online]. Available: <https://link.springer.com/article/10.1007/s40684-020-00229-z>
- [192] Y.-J. Chang, S. Neugebauer, A. Lehmann, R. Scheumann, and M. Finkbeiner, “Life Cycle Sustainability Assessment Approaches for Manufacturing,” in *Sustainable Manufacturing: Challenges, Solutions and Implementation Perspectives*, R. Stark, G. Seliger, and J. Bonvoisin, Eds., in Sustainable Production, Life Cycle Engineering and Management. , Cham: Springer International Publishing, 2017, pp. 221–237. doi: 10.1007/978-3-319-48514-0_14.
- [193] P. Ranjan, R. Agrawal, and J. K. Jain, “Life Cycle Assessment in Sustainable Manufacturing: A Review and Further Direction,” in *Operations Management and Systems Engineering*, A. Sachdeva, P. Kumar, O. P. Yadav, R. K. Garg, and A. Gupta, Eds., in Lecture Notes on Multidisciplinary Industrial Engineering. Singapore: Springer, 2021, pp. 191–203. doi: 10.1007/978-981-15-6017-0_12.
- [194] “Life cycle assessment (LCA) applied to the process industry: a review | The International Journal of Life Cycle Assessment.” Accessed: Dec. 26, 2023. [Online]. Available: <https://link.springer.com/article/10.1007/s11367-012-0432-9>
- [195] M. R. Sabour, H. Zarrabi, and M. Hajbabaie, “A systematic analysis of research trends on the utilization of life cycle assessment in pharmaceutical applications,” *Int. J. Environ. Sci. Technol.*, vol. 20, no. 10, pp. 10921–10942, Oct. 2023, doi: 10.1007/s13762-023-05103-4.
- [196] A. Fnais *et al.*, “The application of life cycle assessment in buildings: challenges, and directions for future research,” *Int J Life Cycle Assess*, vol. 27, no. 5, pp. 627–654, May 2022, doi: 10.1007/s11367-022-02058-5.
- [197] A. Zakerhosseini, M. A. Abdoli, S. M. Molayzahedi, and F. K. Salmi, “Life cycle assessment of construction and demolition waste management: a case study of Mashhad, Iran,” *Environ Dev Sustain*, Aug. 2023, doi: 10.1007/s10668-023-03703-1.
- [198] B. Bayram and K. Greiff, “Life cycle assessment on construction and demolition waste recycling: a systematic review analyzing three important quality aspects,” *Int J Life Cycle Assess*, vol. 28, no. 8, pp. 967–989, Aug. 2023, doi: 10.1007/s11367-023-02145-1.
- [199] J. G. Backes and M. Traverso, “Social Life Cycle Assessment in the Construction Industry: Systematic Literature Review and Identification of Relevant Social Indicators for Carbon Reinforced Concrete,” *Environ Dev Sustain*, Mar. 2023, doi: 10.1007/s10668-023-03005-6.
- [200] M. Kucukvar and O. Tatari, “Towards a triple bottom-line sustainability assessment of the U.S. construction industry,” *Int J Life Cycle Assess*, vol. 18, no. 5, pp. 958–972, Jun. 2013, doi: 10.1007/s11367-013-0545-9.
- [201] Ana T. Amorim-Maia *et al.*, “Intersectional climate justice: A conceptual pathway for bridging adaptation planning, transformative action, and social equity,” *urban climate*, vol. 41, pp. 101053–101053, Jan. 2022, doi: 10.1016/j.uclim.2021.101053.
- [202] Jan Wilkens, Jan Wilkens, Alvine R C Datchoua-Tirvaudey, and Alvine R C Datchoua-Tirvaudey, “Researching climate justice: a decolonial approach to global climate

- governance,” *International Affairs*, vol. 98, no. 1, pp. 125–143, Jan. 2022, doi: 10.1093/ia/iiab209.
- [203] J. Vogel and J. Hickel, “Is green growth happening? An empirical analysis of achieved versus Paris-compliant CO₂–GDP decoupling in high-income countries,” *The Lancet Planetary Health*, vol. 7, no. 9, pp. e759–e769, Sep. 2023, doi: 10.1016/S2542-5196(23)00174-2.
- [204] Prisca Ugomma Uwaoma, Emmanuel Osamuyimen Eboigbe, Simon Kaggwa, Deborah Idowu Akinwolemiwa, and Stephen Osawaru Eloghosa, “Ecological economics in the age of 4ir: spotlight on sustainability initiatives in the global south,” *International journal of advanced economics*, 2023, doi: 10.51594/ijae.v5i9.647.
- [205] G. Enjolras, Magali Aubert, and M. Aubert, “Short food supply chains and the issue of sustainability: a case study of French fruit producers,” Jan. 2018.
- [206] S. Lehmann, “Growing Biodiverse Urban Futures: Renaturalization and Rewilding as Strategies to Strengthen Urban Resilience,” *Sustainability*, vol. 13, no. 5, p. 2932, 2021, doi: 10.3390/su13052932.
- [207] A. Perino *et al.*, “Rewilding complex ecosystems,” *Science*, vol. 364, no. 6438, Apr. 2019, doi: 10.1126/science.aav5570.
- [208] J. Konietzko, “Moving Beyond Carbon Tunnel Vision With A Sustainability Data Strategy,” *Forbes*. Accessed: Jan. 01, 2024. [Online]. Available: <https://www.forbes.com/sites/cognizant/2022/04/07/moving-beyond-carbon-tunnel-vision-with-a-sustainability-data-strategy/>
- [209] C. Benoit-Norris, “The methodological sheets for sub-categories in social life cycle assessment (S-LCA),” *Pre publication- Version. The Methodological Sheets for Subcategories in Social Life Cycle Assessment (S-LCA)*., 2018, doi: 10.1007/978-1-4419-8825-6.
- [210] “Systematic literature review on the application of life cycle sustainability assessment in the energy sector | Environment, Development and Sustainability.” Accessed: Dec. 26, 2023. [Online]. Available: <https://link.springer.com/article/10.1007/s10668-021-01559-x>
- [211] “Bringing nutrition and life cycle assessment together (nutritional LCA): opportunities and risks | The International Journal of Life Cycle Assessment.” Accessed: Dec. 26, 2023. [Online]. Available: <https://link.springer.com/article/10.1007/s11367-021-01982-2>
- [212] “Life Cycle Assessment for the Agri-Food Sector | SpringerLink.” Accessed: Dec. 26, 2023. [Online]. Available: https://link.springer.com/chapter/10.1007/978-94-007-6116-2_5
- [213] “Life cycle-based dashboard for circular agri-food sector | The International Journal of Life Cycle Assessment.” Accessed: Dec. 26, 2023. [Online]. Available: <https://link.springer.com/article/10.1007/s11367-022-02118-w>
- [214] T. Nemecek, N. Jungbluth, L. M. i Canals, and R. Schenck, “Environmental impacts of food consumption and nutrition: where are we and what is next?,” *Int J Life Cycle Assess*, vol. 21, no. 5, pp. 607–620, May 2016, doi: 10.1007/s11367-016-1071-3.
- [215] F. Diaz *et al.*, “The ICCEE Toolbox. A Holistic Instrument Supporting Energy Efficiency of Cold Food and Beverage Supply Chains,” *Environmental and Climate Technologies*, vol. 26, no. 1, pp. 428–440, Jan. 2022, doi: 10.2478/rtuect-2022-0033.
- [216] Statista, “Energy mix in Italy 2018.” 2021. Accessed: Mar. 17, 2021. [Online]. Available: <https://www.statista.com/statistics/873552/energy-mix-in-italy/>
- [217] European Commission, “Facts and figures on the Common Fisheries Policy - Basic statistical data - 2016 Edition,” in *Office of the european union*, 2016.

- [218] L. Proskina, I. Pilvere, A. Nipers, and M. Silovs, “Characteristics of the fishing industry in Latvia,” *19th International Scientific Conference “Economic Science for Rural Development 2018”*. *Bioeconomy. Finance and Taxes. Home Economics. New Dimensions in the Development of Society*, vol. 49, no. 49, pp. 56–64, 2018, doi: 10.22616/esrd.2018.118.
- [219] I. Biuksane and I. Judrupa, “Evaluation of the competitiveness of fisheries sector cluster,” in *Research for rural development*, vol. 2, 2016, pp. 238–245.
- [220] Central Statistical Bureau of Latvia, “Fish catch.” 2017. Accessed: Feb. 09, 2021. [Online]. Available: http://data1.csb.gov.lv/pxweb/en/lauks/lauks_zvejn_ikgad/?rxid=d8284c56-0641-451c-8b70-b6297b58f464&tablelist=true
- [221] I. C. Claussen, E. Indergård, and M. Grinde, “Comparative Life Cycle Assessment (LCA) of production and transport of chilled versus superchilled haddock (*Melanogrammus aeglefinus*) fillets from Norway to France,” *Procedia Food Science*, vol. 1, no. 2211, pp. 1091–1098, 2011, doi: 10.1016/j.profoo.2011.09.163.
- [222] H. M. Hoang, T. Brown, E. Indergard, D. Leducq, and G. Alvarez, “Life cycle assessment of salmon cold chains: Comparison between chilling and superchilling technologies,” *Journal of Cleaner Production*, 2016, doi: 10.1016/j.jclepro.2016.03.049.
- [223] E. S. Hognes, U. Winther, H. Ellingsen, F. Ziegler, A. Emanuelsson, and V. Sund, “Carbon footprint and energy use of Norwegian fisheries and seafood products,” *Sustainable Maritime Transportation and Exploitation of Sea Resources*, pp. 1031–1036, 2011, doi: 10.1201/b11810-152.
- [224] D. Coley, M. Winter, and M. Howard, “Section 4 food distribution and consumption,” in *Sustainable food processing*, John Wiley & Sons, Incorporated, 2013.
- [225] L. Matuko, “LIFE CYCLE ASSESSMENT OF COLD SUPPLY CHAINS: A CASE STUDY OF A LATVIAN EGG PRODUCER,” Riga Technical University, Riga, Latvia, 2023.
- [226] EPD International, *Product Category Rules BIRDS’ EGGS IN SHELL, FRESH*, 2011:15. [Online]. Available: <https://environdec.com/pcr-library/with-documents>
- [227] UNFCC, “Nuevo mondoñedo landfill gas recovery, flaring and energy production and transformation for leachate evaporation.” 2017. Accessed: Nov. 09, 2021. [Online]. Available: <https://cdm.unfccc.int/Projects/DB/ICONTEC1462894251.71/view>
- [228] J. Yliopisto, “Evaluation of potential technologies and operational scales reflecting market needs for low-cost gas upgrading systems. VALORGAS: Valorisation of food waste to biogas,” 2013.
- [229] E. Ryckebosch, M. Drouillon, and H. Vervaeren, “Techniques for transformation of biogas to biomethane,” *Biomass and Bioenergy*, vol. 35, no. 5, pp. 1633–1645, 2011, doi: 10.1016/j.biombioe.2011.02.033.
- [230] F. Bauer, C. Hulteberg, T. Persson, and D. Tamm, “Biogas upgrading – Review of commercial technologies,” 2013.
- [231] W. Stumm and J. J. Morgan, *Aquatic chemistry: chemical equilibria and rates in natural waters*, 3rd Editio. New York: Wiley, 1996.
- [232] S. S. J. Hullu, J. Maassen, “Comparing different biogas upgrading techniques,” 2008.
- [233] A. Bejan, “Economies of scale,” in *Freedom and evolution: Hierarchy in nature, society and science*, Cham: Springer International Publishing, 2020, pp. 13–20. doi: 10.1007/978-3-030-34009-4_2.
- [234] M. A. Ruiz Restrepo, “Bioenergía, una alternativa energética sustentable para Colombia. Aplicación del Concepto Integrado de Sostenibilidad (ICoS),” 2019, Accessed: Jan. 11, 2024. [Online]. Available: <https://repositorio.unal.edu.co/handle/unal/76373>

- [235] Simapro manual PRe Consultants, "Introduction to LCA with SimaPro 7," *PRe Consultants, the Netherlands. Version*, no. October, pp. 1–88, 2008.
- [236] G. Wernet, C. Bauer, B. Steubing, J. Reinhard, E. Moreno-Ruiz, and B. Weidema, "The ecoinvent database version 3 (part I): overview and methodology," *The International Journal of Life Cycle Assessment*, vol. 21, no. 9, pp. 1218–1230, 2016, doi: 10.1007/s11367-016-1087-8.
- [237] IPCC, "Climate change 2013: The physical science basis. Contribution of working group I to the fifth assessment report of the intergovernmental panel on climate change," IPCC, Cambridge, 2013. [Online]. Available: <https://www.ipcc.ch/report/ar5/wg1/>
- [238] "A framework for energy use indicators and their reporting in life cycle assessment - Arvidsson - 2016 - Integrated Environmental Assessment and Management - Wiley Online Library." Accessed: Jan. 06, 2024. [Online]. Available: <https://setac.onlinelibrary.wiley.com/doi/10.1002/ieam.1735>
- [239] M. A. J. Huijbregts *et al.*, "Is Cumulative Fossil Energy Demand a Useful Indicator for the Environmental Performance of Products?," *Environ. Sci. Technol.*, vol. 40, no. 3, pp. 641–648, Feb. 2006, doi: 10.1021/es051689g.
- [240] A. M. Boulay *et al.*, "The WULCA consensus characterization model for water scarcity footprints: assessing impacts of water consumption based on available water remaining (AWARE)," *The International Journal of Life Cycle Assessment*, vol. 23, no. 2, 2017, doi: 10.1007/s11367-017-1333-8.

PUBLICATIONS ARISING FROM THIS THESIS

Article 1: Effects of Energy Efficiency Measures in the Beef Cold Chain: A Life Cycle-based Study

Effects of Energy Efficiency Measures in the Beef Cold Chain: A Life Cycle-based Study

Fabian DIAZ^{1*}, Jacopo Andreas VIGNATI², Beatrice MARCHI³, Riccardo PAOLI⁴,
Simone ZANONI⁵, Francesco ROMAGNOLI⁶

^{1,6} *Institute of Energy Systems and Environment, Riga Technical University, Azenes iela 12/1,
Riga, LV-1048, Latvia*

^{2,3,5} *Univerista degli studi di Brescia, Via Branze 38, Brescia, 25123, Italy*

⁴ *Università Degli Studi Dell'insubria, Via Ravasi 2, Varese, 2110, Italy*

Abstract – Circular economy and industrial symbiosis represent a production and consumption model involving sharing, lending, reusing, and recycling existing materials and products in the most efficient way to increase sustainability and reduce or eliminate waste. Beef production has a high impact on the environment in different impact categories, especially those activities related to livestock breeding and feeding. In this study, a life cycle assessment and a life cycle cost evaluation are carried out investigating potential energy efficiency measures to promote industrial symbiosis scenarios referring to a proposed baseline scenario. Three main potential measures are evaluated: energy recovery from waste via anaerobic digestion, integration of renewable sources at warehouses, including solar PV panels, and the replacement of auxiliary equipment at the retailer. It was found that energy reconversion of food waste through anaerobic digestion and cogeneration provides the most valuable benefits to the supply chain. From the economic perspective, using a conventional life cycle cost assessment, the energy production from the use of wastes for anaerobic digestion proved to be the best potential option.

Keywords: LCA; LCC; cold chain; beef; circular economy; industrial symbiosis; sustainability

Nomenclature

GHG	Greenhouse gases
SDG	Sustainable Development Goals
SETAC	Society of Environmental Toxicity and Chemistry
LCA	Life Cycle Assessment
LCC	Life Cycle Cost
ISO	International Standard Organization
FU	Functional Unit
LCI	Life Cycle Inventory
EEM	Energy Efficiency Measure

* Corresponding author.
E-mail address: Fabian-andres.diaz-sanchez@rtu.lv

1. INTRODUCTION

The growing population and market conditions have increased per capita food demand mainly in developing countries [1]. Such boost in demand has created a rapid expansion in the livestock industry in developed and developing countries [2], [3], therefore also increasing the environmental toll associated with it, impacting greenhouse gases (GHG) emissions, deforestation, and land degradation [4].

The environmental impact of beef production shows a wide range of results mainly because of different methodological choices and fundamental cattle production systems that change among regions [1]. Moreover, beef meat farming is involved in several of the global Sustainable Development Goals (SDG) set by the United Nations. In particular, it contributes to SDG1 (zero hunger), SDG3 (good health and wellbeing), and SDG8 (decent work and economic growth) [5]. Nevertheless, meat production can also have an impact on other SDG, such as SDG13 (climate action) and SDG15 (life on land), as beef and sheep production has increased by 44 % and 56 % respectively from 1970 to 2018 worldwide [5].

The food supply chain (FSC) plays an essential role in ensuring the sustainability of meat production and distribution, as it is during the last stages of the FSC where most food is wasted [6]. According to [7], the produced but uneaten food represents almost 1.4 billion hectares of used land, which is equivalent to nearly 30 % of the world's total agricultural land. Furthermore, it has also been estimated that one ton of wasted food is responsible for the emissions of 4.5 CO₂ ton to the atmosphere contributing to methane formation once disposed of in a landfill.

Due to these reasons, the FSC has to be addressed from a sustainability and holistic point of view to optimize the agricultural sector's benefits and results [8]. By using a life cycle assessment (LCA) tool, it is possible to evaluate the overall sustainability of the food industry essentially related to the number of natural resources utilized, the human necessity for nourishment, and generally the dependence of communities on food for subsistence.

The need to use assessment tools for strengthening the food supply chain sustainability is also proposed in the study of M. Soysal *et al.* [9]. The authors emphasize the innate features in food products that require added efforts in logistics due to environmental and quality concerns. This finding also highlights the need for decision support tools that enable to incorporate the economic issue with food quality and environmental ones in the FSC, as the main challenges for sustainability managing.

This study has been conducted during the EU-funded H2020 project: 'Improving cold chain energy efficiency' (ICCEE) [10].

2. METHODOLOGY

The term life cycle assessment (LCA) was coined in 1990 during the SETAC (Society of Environmental Toxicity and Chemistry) congress held in Vermont (USA). The definition given at that time, and still widely accepted today, describes LCA as 'an objective process of evaluating the environmental burdens associated with a product, process, or activity, conducted through the identification and quantification of energy and materials used and wastes released into the environment, to assess the impact of these energy and material uses and releases on the environment, and to evaluate and implement opportunities for environmental improvement. The assessment encompasses the entire life cycle of the product, process, or activity, including extraction and treatment of raw materials, manufacturing, transportation and distribution, use, reuse, maintenance, recycling, and final disposal' [11].

In this study, the authors propose an LCA model for the beef cold chain. Specifically, the authors compare a baseline scenario and scenarios with a hypothetical scenario implementing energy efficiency measures from the circular economy and industrial symbiosis solution. The study aims to assess the environmental impacts in the regional and local supply chain in a European context.

Specifically, this study was carried out with the ISO 14040 and 14044:2006 standards [12] implementing the LCA methodology in a four-stage standardized procedure. *SimaPro 9.0* [13] software developed by Pré Consultants and *Ecoinvent 3.0* [14] were used for the creation of the LCA model and the overall environmental impact was evaluated using the IMPACT 2002+ method [18].

2.1. Goal and scope definition

2.1.1. Goal

This study aims to evaluate the environmental impacts of a regional and local beef cold chain in a European context. The beef cold chain is very complex and may include several actors, an undefined number of stages such as processes of slaughtering, processing, storage, and transport activities in different geographical areas.

In this LCA study, the performance of four scenarios (including the baseline scenario) are compared and analyzed, namely:

1. Baseline scenario;
2. Energy recovery scenario through the transformation of biowaste into biogas with subsequent cogeneration of heat and power (CHP) – EEM1 scenario;
3. Renewable energy use (photovoltaic solar energy) – EEM2 scenario;
4. Efficient compressors replacement – EEM3 scenario.

2.1.2. Scope

The supply chains under study were modeled without considering the end consumer step. This stage can be very flexible and unpredictable, in fact depending on the type of consumers, their needs, living conditions, energy consumption, geographical area, social conditions, political, economic, and environmental constraints, and finally, the type of end consumer (e.g., household, restaurant, hotel, canteen, etc.).

The processing stage for the regional beef cold chain contains a larger, more articulated, and highly diversified production process that accommodates more products than the local one's processing stage. In both scenarios, the processing phase also includes the post-processing storage of the beef. Transportation was considered from farm to slaughterhouse, from slaughterhouse to processing, from processing to a central distributor, and from a central distributor to wholesale and retail.

The main differences considered between the regional and local supply chain are the size and energy consumption of the processing and storage phase, different product demands in the processing and storage phase, transport distances, especially from the processing and storage phase to the distribution center, and the geographical contextualization in which the two (i.e., local and regional) supply chains work. These activities are shown in Fig. 1.

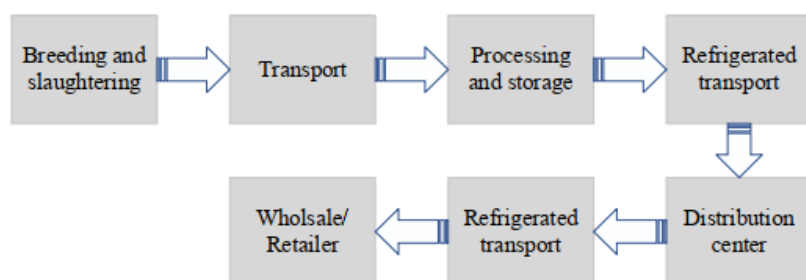

Fig. 1. Modeled supply chain.

2.1.3. Functional unit

In this study, the functional unit (FU) is represented by 1 kg of beef delivered at the wholesaler or retailer, so all the reported values (such as energy consumption, packaging, waste, water, transport, etc.) across the life cycle have been normalized on 1kg of product.

2.1.4. Geographical boundaries

A distinction between regional and local supply chains is made as follows: the regional cold chain begins with the breeding in Villareal (Spain), moving to the slaughter in Tarragona (Spain) with a transport distance of 200 km, and then arrives in Lleida (Spain), for the meat processing and storage phase (100 km of distance); from Lleida, the beef is transported to Italy to reach the distribution center located in Florence with a distance of 1240 km, and finally, within Florence, the beef is transported to the city's supermarkets center with a further transport of 20 km.

The local beef cold chain begins with the breeding in Tolmezzo (Italy), moving to slaughter in Castelfranco Veneto (Italy) with a transport of 200 km, and then the raw beef is transported to Verona (Italy) for processing (100 km). From Verona, the beef products are transported to the Rome distribution center (Italy) for 500 km and finally, in Rome, the food product is distributed in the supermarkets of the city with a further transport of 20 km.

2.2. Life cycle inventory

Life cycle inventory (LCI) represents the LCA phase for the collection of data to be implemented in each scenario necessary for the assessment of the potential environmental impacts from the regional and local beef cold chain. In the LCI, data are referred and normalized to the functional unit of 1kg of beef delivered. For the implementation of the inventory data, the following databases related to the inventory processes in SimaPro were used:

- *Ecoinvent 3*. The *Ecoinvent v3.6* database [14] contains LCI data from various sectors such as energy production, transport, building materials, production of chemicals, metal production, and fruit and vegetables;
- *Agri-footprint* [15]. This database includes linked unit process inventories of crop cultivation, crop processing, animal production systems, and processing of animal products for multi-impact life cycle assessments.

In this study, data from two different processing companies in Italy was obtained, both conducting activities such as cutting, freezing, and packaging of beef [16]. For data related

to water and electricity consumption, packaging, and industrial area in the processing phase, the company with the higher annual production (i.e., 3000 t/year) was considered for the regional chain, while the one with smaller capacity was considered for the local supply chain (i.e., 1200 t/year). The same amount of electricity consumption in the breeding and slaughtering phase for the regional and local beef cold chain was considered. The companies providing such information were partners of the ICCEE project or companies interviewed within the ICCEE project implementation.

Electricity consumption is one of the recurrent inflows in most of the process as it is used for slaughtering, production and refrigeration activities, in both the regional and local cold chains. Thermal energy is used in the slaughtering and processing step to supply hot water and hot air, for hygiene, and space heating in several other stages of the beef cold chain. Water consumption is used for refrigeration, slaughtering, processing, storage and transport. In the transport activities, it is assumed the truck engine drives the refrigeration system.

The transport activity (from the slaughterhouse to the processor) is modeled as waste-free, assuming 1.66 kg of meat per functional unit (FU) as input and output in the process. The only unit process considered in this step is the vehicle operation for 100 km (Freight lorry > 32 metric ton, EURO 5) for both regional and local supply chains.

The processing stage in the supply chain is performed considering data available from an existing warehouse. Refrigerant type R134a and the average occupation of the storage room of 90 % were assumed. All other relevant data for this activity are presented in Table 1. The activities performed in this stage include cutting, freezing, packaging, and later storage of previous transport to the distribution center.

TABLE 1. LCI FOR PROCESSING STAGE (NORMALIZED TO FU)

Material	Regional	Local
Output – Frozen meat (beef), kg	1.0	1.0
Output - Meat organic waste, kg	0.66	0.66
Input – Raw meat, kg	1.66	1.66
Thermal energy, MJ	2.391	2.391
Electricity, kWh	0.14742	0.12346
Tap water, kg	0.013	0.0042
Packaging material - polyethylene, low density, granulate, kg	0.000056	0.000066
Packaging film, low density polyethylene, kg	0.0046	0.00583
Occupation industrial area, m ²	0.000221833	0.00031

After the processing unit, the next stage of the cold chain is transport to the distribution center, using a freight lorry 7.5–16 ton capacity with a refrigeration unit driven by the main truck engine using R134a as a refrigerant. This unit process is taken directly from the Ecoinvent database and adjusted to a transport distance of 1240 km for the regional cold chain and 500 km for the local one. Softened water is used in this stage and just as in the previous transport activity, this stage is considered waste-free. The inventory for the storage activity is presented in Table 2.

The last transport activity, from the distribution center to the retailer or wholesale place, is modeled using the unit process found in Ecoinvent as 'Freight lorry 3.5–7.5 ton with refrigeration machine, R134a refrigerant, EURO5', for a total distance of 20 km in the regional and local supply chain models. Again, this stage is considered waste-free. The last stage in the supply chain is the retailer facilities' storage as presented in Table 3.

TABLE 2. LCI FOR STORAGE AT THE DISTRIBUTION CENTER (NORMALIZED TO FU)

Material	Regional	Local
Output – Frozen meat (beef), kg	1.0	1.0
Input – Frozen meat, kg	1.0	1.0
Electricity, kWh	0.01957	0.01957
Tap water, kg	0.034463	0.0282
Occupation industrial area, m ²	0.000002712	0.000002712

TABLE 3. LCI FOR STORAGE AT RETAILER/WHOLESALE (NORMALIZED TO FU)

Material	Regional	Local
Output – Frozen meat (beef), kg	1.0	1.0
Input – Frozen meat, kg	1.0	1.0
Electricity, kWh	0.04	0.04
Occupation industrial area, m ²	0.000042462	0.000042462

2.3. Energy Efficiency Measures

In this study, three different types of energy efficiency measures (EEM) are evaluated in terms of renewable energy and energy recovery intervention and intervention on auxiliary technologies. The scenarios are described in detail in the following subsections.

2.3.1. Energy Recovery (EEM-1)

This measure is considered applied at the first and third stages of the supply chain, at the slaughterhouse and processor's facility. The transformation of biowaste generated from the standard activities conducted in these facilities into biogas by anaerobic digestion and subsequent cogeneration of heat and power (CHP) is modeled considering the study conducted by [17]. The authors of the study assume that meat biowaste can be processed in bioreactors to produce biogas through anaerobic digestion.

In the present study, it is assumed that biogas is used to generate electricity and thermal energy, with an industrial cogeneration unit, to re-use them in the slaughtering and processing stages. This scenario is in line with the application of both circular economy principles (i.e., valorization, recycling, and reuse of meat biowaste) and industrial symbiosis (i.e., sharing of bioresource within a synergic and efficient network). Nonetheless, electricity and heat can be shared with other networks integrating them in other supply chains, companies, or even communities boosting industrial symbiosis.

In the stages under consideration for implementing the EEM-1, it is assumed that 90 % of the biowaste fraction can be converted effectively into biogas [17], and further injected into a 90 % efficiency CHP plant.

Calculated potential new consumptions or energy outputs to the grid are displayed in Table 4 for both supply chain scenarios. Whenever the produced energy is higher than the facility's demand and extra energy is available to be sold, a positive number is expressed, while a negative value means the energy internally produced is not enough and consumption from the grid is still required in the displayed amount. Values are referred to as the functional unit.

TABLE 4. NEW ENERGY CONSUMPTIONS AFTER IMPLEMENTING EEM-1

		At Slaughtering, MWh	At Processing, MWh
Regional supply chain	Electricity consumption (-) /prosumption (+)	0.000110824	0.000257912
	Heat consumption (-) /prosumption (+)	0.000278743	0.000179739
	Electricity consumption (-) /prosumption (+)	0.000110824	0.000281877
Local supply chain	Heat consumption (-) /prosumption (+)	0.000278743	-0.000179739

2.3.2. Renewable Energy Production and use (EEM-2)

The second EEM scenario evaluates the production of renewable energy at the storage stage in the distribution center. Aiming to reduce fossil fuel usage, refrigeration driven by solar energy has become one of the promising approaches to reduce or partially replace conventional refrigeration systems. The technology is almost mature to compete with conventional cooling equipment but remains highly dependent on climatic conditions.

For the particular case, a photovoltaic slater-roof installation of crystalline silicon panels with a total peak power of 2378.33 kW_p was modeled based on calculations considering a PV farm with 793 panels installed at the distribution center facilities in Florence and Rome, Italy. The total electricity production was calculated for both scenarios taking into account the two different geographical locations, reducing the electricity consumption from the national grid by 1.12 % and 1.02 % in the regional and local supply chain scenarios, respectively.

2.3.3. Efficient compressor replacement (EMM-3)

The third EEM measure applied in the life cycle model is the replacement of efficient compressors in the wholesale/retail stage (supermarket) of the meat cold chain. This energy efficiency measure consists of installing new compressors that are virtually capable of covering a larger portion of the cold load. The switching of compressors may result in a significant reduction in electricity consumption and CO₂ savings. It can also improve working conditions and safety due to an ammonia leakage detection system that can be installed with the new system. Other significant benefits are the increased lifespan, lower maintenance costs, and improved control system.

It was further assumed that replacing all old compressors with new ones, including new inverters (7.5 kW), can save up to 20 % of electricity per year at the retailer stage in the supply chain. The equipment replacement was included in the inventory for both supply chains and electricity consumption adjusted accordingly to a 20 % of electricity savings.

3. LCA RESULTS

From a first analysis, no differences in the results were observed from one scenario to the other, despite the modeled changes considering different EEMs. This is explained as the breeding and slaughtering phase are the main driver in the overall environmental impact in the supply chain, with more than 95 % of the total impact allocated to this stage. Hence, it was considered to exclude it from the cold supply chain to distinguish the effects of the EEM scenarios more clearly in the remaining stages.

The baseline scenario weighted results for the regional supply chain are shown in Fig. 2, including the total single score representation per stage and the disaggregated impact per each area of concern.

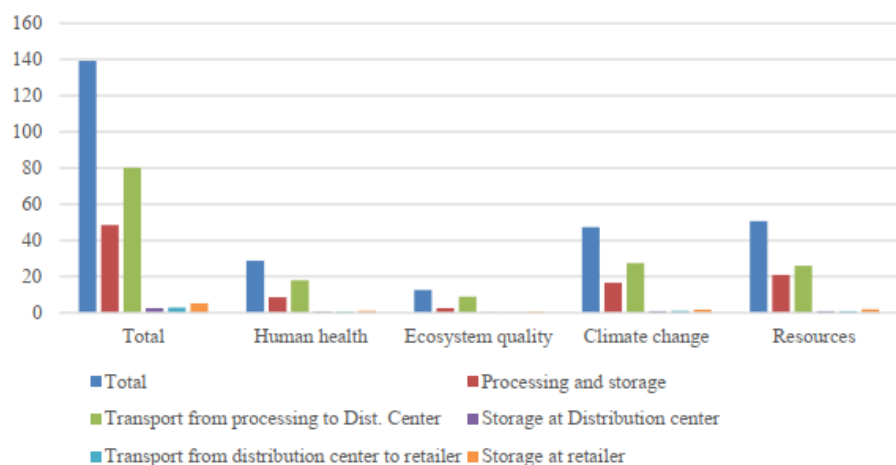

Fig. 2. Weighted results per stage for the baseline scenario in the regional supply chain.

A total environmental impact of 140 mPt was found for the regional supply chain scenario. The most relevant stages are transport from the processing facility to the distribution center followed by the processing phase.

When looking at the areas of concern, the environmental burden is mainly in the area of climate change, resource consumption, and slightly less on human health, leaving the ecosystem quality only mildly affected. For the local beef supply chain, the results are similar since most activities require similar energy consumption and are performed very similarly. Nevertheless, the shorter distance for transport activities, especially for reaching the distribution center after processing, makes this supply chain less environmentally intense, with a total score of 90 mPt.

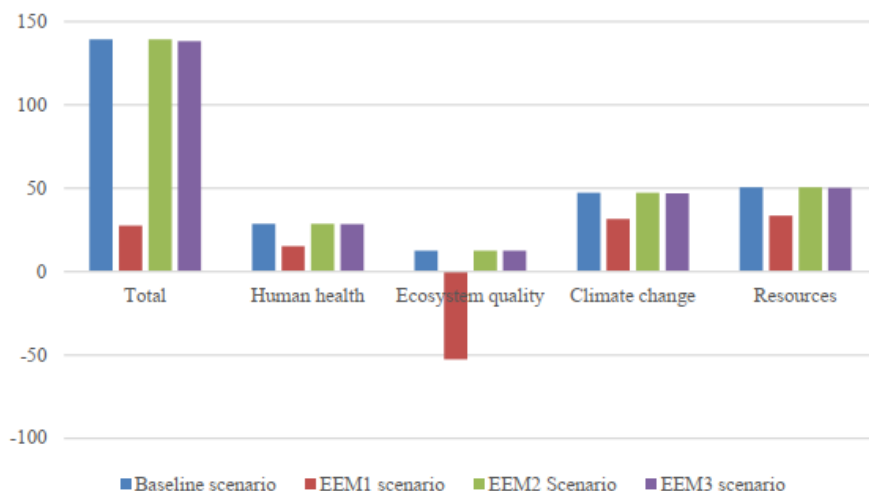

Fig. 3. Weighted results comparison for the regional supply chain.

The comparison graph displayed in Fig. 3, shows how EEM-1 is the one that brings the most environmental benefits in every single area of concern, while the other EEM scenarios barely show any difference when compared with the baseline. The EEM-1 scenario might also potentially deliver environmental credits to the ecosystem quality area, due to avoiding electricity consumption from the country mix, which is mainly linked to the use of fossil fuels and land use for hydropower production [18].

Since the local supply chain has lower impact due to lower transportation distances, the savings created by the EEM-1 scenario make a bigger impact on its overall result, showing even a negative value (environmental benefit) for the entire food supply chain.

As for the regional supply chain, the local scene is not affected by implementing the energy efficiency measures 2 and 3, as shown in Fig. 4.

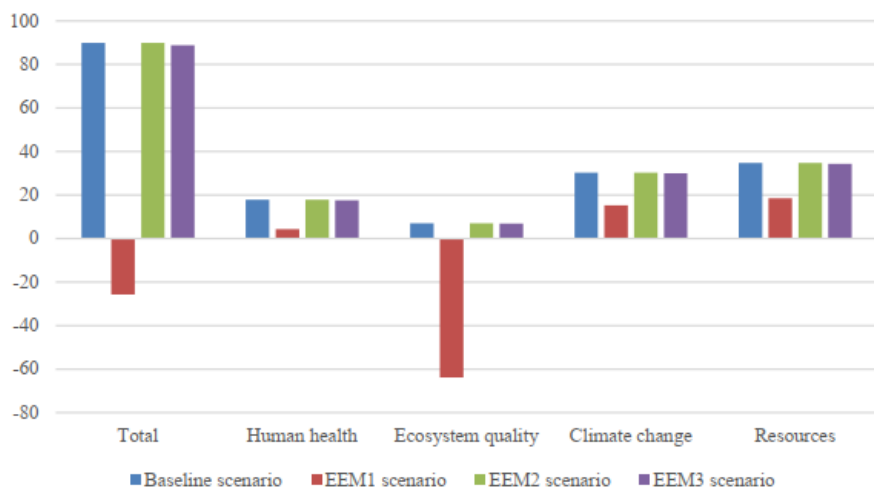

Fig. 4. Weighted results comparison for the local supply chain.

4. LIFE CYCLE COST

Life cycle cost (LCC) is a versatile technique that can be applied for various purposes and at different stages of a project's life cycle to support decision-making. It might be undertaken both as an absolute analysis (e.g., to support the process of budgeting) and as a relative analysis (e.g., to compare alternative technologies). Three variants of LCC can be distinguished: Conventional LCC, Environmental LCC, and Societal LCC.

The conventional LCC, also called financial LCC can be considered synonymous with Total Cost of Ownership [19].

In this work, a comparative and conventional approach was undertaken between the baseline and different energy efficiency measures scenarios. This task was achieved by analyzing the required investments from different beef cold chain actors for each scenario evaluating each investment's economic convenience.

As changes between the modeled regional and local supply chain mainly distinguish from each other only at the transport activities, and EEM scenarios in this study are only

implemented at the level of the processing or storage stages, only the regional supply chain is considered for the LCC evaluation.

The baseline scenario's cost structure for comparison with the EEM-1 is presented in Annex 1, and the investment required for the construction of anaerobic digestion and cogeneration of heat and power plants was estimated at 26 878 EUR. Potential new running costs after EEM-1 are implemented are shown in Annex 2 and include a reduction in electricity and heat consumption as well as an increase in labour costs due to new equipment operation. The financial scheme consists of an annual interest loan rate of 10 %, a required rate of return of 20 %, and a share of investment supported by equity of 30 %. The inflation was taken from the Italian average value in the last 5 years (0.6 %).

For the comparison between the baseline scenario and EEM-2, the warehouse's running costs are presented in Annex 3, and the total costs for investment were estimated at 3 567 495 EUR. For this case, the financial conditions considered were a required rate of return of 14 %, an interest rate on the loan of 6.0 %, and an inflation of 0.6 %. Similarly, the EEM-3 running costs comparative scenario is presented in Annex 4, considering an electricity reduction of 20 %. The compressor replacement cost was estimated at 6800 EUR and the same financial conditions as in EEM-2 were considered.

For the economic evaluation, budget and market prices were used, referring to the specific regions' market conditions where activities are modeled.

After a sensitivity analysis, it was found that the changes in market prices for beef could either positively or negatively affect the internal rate of return or the profit index of the evaluated projects if the production capacity of the plants remains constant in time. Net Present Value (NPV) analysis shows that the EEM-1 is the most attractive one from the economic perspective.

5. CONCLUSIONS

The study provides an insight on the environmental and economic sustainability towards the cold supply of beef meat. From a holistic perspective implemented with an LCA and conventional LCC, this study highlights the potential effects of specific EEMs within a local and regional context.

The study considered four different scenarios implemented within the regional and local context, taking into a baseline scenario and three types of EEM scenarios implementing both energy efficiency solutions, circular economy and industrial symbiosis, and integrating renewable energy technologies.

The study shows that the breeding and slaughtering phase of the beef cold chain is the environmental hotspot overtaking most of the overall potential impacts in the supply chain. This is due to the land use required for the livestock, methane emissions from ruminants, and its food production cycle.

Within an internal and deeper analysis, the weighted results at mid-point impact categories show that categories such as 'Non-carcinogens', 'Terrestrial ecotoxicity' and 'Land occupation' are the most affected for the four scenarios considered in the global beef cold chain. In the local supply chain, the same categories as in the regional supply chain are found to be the most impacted ones. Among the mid-point categories, the 'Non-carcinogens' impact category represents about 18 % of the total impact, 'Terrestrial ecotoxicity' contributes with near 70 %, and 'Land occupation' covers about 9 %, mainly from the breeding and slaughtering activities.

At the end-point level, the ecosystem quality category represents near 80 % of the total impact, while the human health category represents about 22 % in the four scenarios, both for regional and local supply chains.

It was also found that long transport distances can negatively affect the beef supply chain due to the fuel consumption invested in the trip and required for running the refrigeration units. The processing stage is a key contributor to the cumulative environmental load across the supply chain due to the different activities in the facilities such as meat cutting, internal transport, packaging, handling waste, and storage of previous waste. This finding is disregarding the length of the supply chain. To these intrinsic sub-processes, the administration activities requiring personnel in the building might increase the whole process energy expenditure to ensure a comfortable environment that comes with the use of either air conditioners or heaters, depending on the season.

When the breeding and slaughtering phase is excluded from the LCA, results show that the most affected areas are climate change and the use of resources, followed by human health. By evaluating the three alternatives considered in this study, it is found that the production of energy from waste via anaerobic digestion and a cogeneration plant (EEM-1), is the one that delivers more benefits to the environmental performance of the supply chain.

The EEM-2 does not bring environmental benefits to the supply chains under evaluation as the energy savings are barely in the order of 1 % and still require installing a large PV system. On the other hand, EEM-3 could save up to 20 % of electricity consumption from the electricity mix but requires installing new devices, the environmental burden of which is related to its manufacturing process and overlaps the potential benefits.

The study emphasizes the need to move towards evaluating energy efficiency interventions towards the food cold supply chain to find the optimal condition (both environmental and economic) for the entire actors involved in the whole supply chain rather than the single actor.

Further research will be necessary to evaluate the effect of quality losses on the considered supply chain.

ACKNOWLEDGMENT

This work has received funding from the European Union's Horizon 2020 research and innovation program ICCEE project under the grant agreement no. 84704.



REFERENCES

- [1] Vries de M., Middelaar van E. C., Boer de M. J. I. Comparing environmental impacts of beef production systems: A review of life cycle assessments. *Livestock Science* 2015;178:279–288. <https://doi.org/10.1016/j.livsci.2015.06.020>
- [2] Gerber P. J., et al. Tackling climate change through livestock: a global assessment of emissions and mitigation opportunities. Rome: Food and Agriculture Organization of the United Nations (FAO), 2013.
- [3] Thornton P. K., Herrero M. The Inter-Linkages Between Rapid Growth In Livestock Production, Climate Change, And The Impacts On Water Resources, Land Use, And Deforestation. *Policy Research Working Papers*, 2013. <https://doi.org/10.1596/1813-9450-5178>
- [4] Cederberg C., Mattsson B. Life cycle assessment of milk production - a comparison of conventional and organic farming. *Journal of Cleaner Production* 2000;8(1):49–60. [https://doi.org/10.1016/S0959-6526\(99\)00311-X](https://doi.org/10.1016/S0959-6526(99)00311-X)
- [5] Segerkvist K. A., Hansson H., Sonesson U., Gunnarsson S. A Systematic Mapping of Current Literature on Sustainability at Farm-Level in Beef and Lamb Meat Production. *Sustainability* 2021;13(5):2488. <https://doi.org/10.3390/su13052488>
- [6] Heising K. J., Claassen H. D. G., Dekker M. Options for reducing food waste by quality-controlled logistics using intelligent packaging along the supply chain. *Food Additives & Contaminants: Part A*. 2017;34:1672–1680. <https://doi.org/10.1080/19440049.2017.1315776>
- [7] Stenmarck Å. et al. Estimates of European food waste levels. Technical report, 2016.

- [8] Notamicola B., Hayashi K., Curran A. M., Huisingh D. Progress in working towards a more sustainable agri-food industry. *Journal of Cleaner Production* 2012:28:1–8. <https://doi.org/10.1016/j.jclepro.2012.02.007>
- [9] Soysal M., Bloemhof-Ruwaard M. J., Van Der Vorst J. A. G. J. Modelling food logistics networks with emission considerations: The case of an international beef supply chain. *International Journal of Production Economics* 2014:152:57–70. <https://doi.org/10.1016/j.ijpe.2013.12.012>
- [10] ICCEE. [Online]. [Accessed 04.01.2021]. Available: <https://iccee.eu>
- [11] Simonen K. *Life cycle assessment*. London: Routledge, 2014. <https://doi.org/10.4324/9781315778730>
- [12] ISO. ISO 14044:2006. Environmental management — Life cycle assessment — Requirements and guidelines. *International Organization for Standardization*, 2006.
- [13] Simapro manual PRé Consultants. Introduction to LCA with SimaPro 7. *PRé Consult. Netherlands. Version*, no. October, pp. 1–88, 2008, [Online]. [Accessed 05.03.2021]. Available: <http://scholar.google.com/scholar?hl=en&btnG=Search&q=intitle:Introduction+to+LCA+with+SimaPro+7#0>
- [14] Wernet G., Bauer C., Steubing B., Reinhard J., Moreno-Ruiz E., Weidema B. The ecoinvent database version 3 (part I): overview and methodology. *The International Journal of Life Cycle Assessment* 2016:21:1218–1230. <https://doi.org/10.1007/s11367-016-1087-8>
- [15] Blonk Consultants. Agri Footprint. [Online]. [Accessed 05.03.2021]. Available: <https://www.agri-footprint.com/>
- [16] Zaroni S., Marchi B. Deliverable 3.1 - Improving Cold Chain Energy Efficiency in food and beverage sector, 2020.
- [17] Ware A., Power N. Biogas from cattle slaughterhouse waste: Energy recovery towards an energy self-sufficient industry in Ireland. *Renewable Energy* 2016:97:541–549. <https://doi.org/10.1016/j.renene.2016.05.068>
- [18] Statista data of Energy mix in Italy 2018. [Online]. [Accessed 17.03.2021]. Available: <https://www.statista.com/statistics/873552/energy-mix-in-italy/>
- [19] Wouters M., Anderson C. J., Wynstra F. The adoption of total cost of ownership for sourcing decisions— structural equations analysis. *Accounting, Organization and Society* 2005:30(2):167–191. <https://doi.org/10.1016/j.aos.2004.03.002>

ANNEXES

ANNEX 1. COST STRUCTURE FOR EEM–1(BASELINE)

	Project costs		Unit	Baseline
Running costs/Cost Categories	Operation and maintenance	Electricity	€/year	52 875
		Labour costs	€/year	340 000
		Water	€/year	88
		Refrigerants	€/year	375.6
		Thermal energy	€/year	97 633
	Production costs	Raw material – Beef	€/year	8 070 000
		Packaging material 1	€/year	166.6
		Packaging material 2	€/year	43 400

ANNEX 2. RUNNING COSTS STRUCTURE FOR THE IMPLEMENTED EEM–1 AT THE PROCESSING STAGE

	Project costs		Unit	Baseline	EEM1
Running costs/ Cost Categories	Operation and maintenance	Electricity	€/year	52 875	–
		Labour costs	€/year	340 000	493 000
		Water	€/year	88	88
		Refrigerants	€/year	375.6	375.6
		Thermal energy	€/year	97 633	26 422
	Production costs	Raw material – Beef	€/year	8 070 000	8 070 000
		Packaging material 1	€/year	166.6	166.6
		Packaging material 2	€/year	43 400	43 400

**ANNEX 3. COST STRUCTURE FOR BASELINE VS EMM-2 IMPLEMENT SCENARIO
(AT WAREHOUSE STAGE)**

Project costs		Unit	Baseline	EEM2	
Running costs/Cost Categories	Operation and maintenance	Electricity	€/year	41 182 200	40 770 378
		Labour costs	€/year	400 000	560 000
		Water	€/year	849 170	849 170
		Refrigerants	€/year	238 944	238 944

**ANNEX 4. COST STRUCTURE FOR BASELINE VS EMM-3 IMPLEMENTED SCENARIO
(AT A RETAILER)**

Project costs		Units	Baseline	EEM3	
Running costs/Cost Categories	Operation and maintenance	Electricity	€/year	3006	2405
		Labour costs	€/year	300 000	300 000
		Refrigerants	€/year	500.8	500.8

**Article 2: Energy Efficiency Measures on Cold Supply Chains Problem
identification and gaps for the fish sector**

ENERGY EFFICIENCY MEASURES ON COLD SUPPLY CHAINS

Problem identification and gaps for the fish sector

Fabian Andres Diaz Sanchez, Lolita Koiro, Francesco Romagnoli

Institute of Energy Systems and Environment

Riga Technical University

Riga, Latvia

Fabian-andres.diaz-sanchez@rtu.lv

Abstract—In this paper, a literature review on studies addressed to understand the environmental impacts caused by the fish supply chains and potential energy efficiency measured in Europe is performed. A general definition of the cold chain is provided along with its main topicalities, such as quality degradation, food losses, social and environmental issues. The local fishery sector relevance is described for Latvia and then a bibliographic analysis is performed using a specialized tool that allows recognizing the main topics covered in the last years within the scientific community. Results show a lack of studies focuses on recognizing the benefits or setbacks of implementing energy efficiency measures in actors across the supply chain.

Keywords—cold chain; fishery sector; Latvia; energy efficiency measure

I. INTRODUCTION

The food and beverage sector in the EU has a high relevance, accounting for around 12.8% of the added value in manufacturing [1], including 280,000 companies and 4.3 million employees. The sector's turnover in 2012 was over 1,000 billion euros (i.e. 14.6% of the total EU manufacturing sector) and the embedded energy accounts for more than 25% of the EU-27 total final energy consumption [2], [3].

As demand for fresh food has grown with the rising population, this has brought the necessity for increased innovation and technological novelties to overcome the capacity and infrastructure restrictions related to food production and distribution. At the same time, this trend could alleviate the emergence of risks to ensure food quality at the end of the supply chain. The cold chain is one of the tools that aid in pursuing this goal.

Parties concerned across the Food Supply Chain (FSC) aim to decrease their energy consumption by undertaking energy efficiency towards sustainable developing principles by implementing energy audits in their activities. However, energy audits provide only a picture of the current condition at a specific stage, and thus of a single actor of the whole supply chain. In this way, the sustainability of energy efficiency measures and their potential benefits across all the supply chain should be evaluated from a holistic perspective.

Hence, to reduce the energy consumption in FSC it is necessary to understand and identify the hotspots for

stakeholders to take the essential measures. This analysis requires a holistic approach that avoids burden-shifting; therefore, a determined actor on the chain would be able to identify its opportunities for improvement.

Moreover, research studies showed in different contexts the effect of the low implementation of energy efficiency in companies attested by energy audits is often no higher than 50% [4].

The main barriers to releasing the potential energy efficiency measures (EEM) are scarce financing, lack of awareness, lack of knowledge, and unsuitable choice of key performance indicators and tools that hamper the efforts to select the best cost-effective measures [5] [3]. This is a major drawback especially for small and medium-sized companies (SMEs). They tend to suffer from limited awareness of these opportunities and they often lack applicable methods and tools to quantify and address energy efficiency in their companies.

SMEs in the industrial sector have a slight awareness of the opportunities that some energy efficiency measures might bring over the entire supply and mostly, they lack methods and tools to implementing them [3] [6]. Moreover, the impacts delivered by specific energy efficiency measures depending on the particular industry sector and the actor implementing them. Therefore, custom-made approaches are required.

The energy costs respect the total production costs in the food sector a key aspect to consider (i.e., dairy-based manufacturing products have energy costs about 11% of the production added value [2]). That is why energy efficiency in the food and beverage sector's cold supply addresses several multidisciplinary aspects: energy expenditure (around 15% of the total energy is in connection to cold chains and cooling systems [7]), and 40% of all food deliveries needs refrigeration or chilling [8]), economy, cold supply chains involve a wide spectrum of companies from different industrial sectors [3], and society and environment, as the back-streams of cold chains many time belongs on intensive land and resource use.

At a local level, and considering the background before presented, it is important to identify the improvement opportunities in the different sub-sectors in the Latvian food industry. In this document, the fish sector is reviewed. A literature review on this topicality is conducted upon the

fishery sector to identify the state of the art on implementing EEM, its derivative environmental issues, and if gaps exist.

II. LITERATURE REVIEW

The cold chain plays a key role in reducing food waste and ensuring food safety, which influences changes in the environment, water, and land resources [9], [10].

Although the cold chain is an important tool to ensure food safety and prologues shelf life, the low-temperature requirements create an extra load in energy and refrigerant consumption. FSC activities also result in the consumption of fuels for powering refrigeration units, vehicles, and facilities along the supply chain, all resulting in environmental impacts that should be quantified if the overall performance is to be evaluated.

A cold chain includes, but is not limited to, cooling and freezing foods and the later refrigeration; or the refrigeration of food after harvesting, transportation, storage, retail distribution, and storage at household, aiming to preserve the quality, safety and to extend the lifetime of the products for consumers [11].

A. Main social and environmental aspects of the FSC

Although globalization improved the profitability of FSC across borders, it also led to enlarged distances among the supply chain partners. The growth in the international food trade and the increase in transportation distances set the conditions for a larger environmental impact of the FSC.

Under international markets, the distance that the food needs to travel to reach the end consumers has increased the use of resources, energy, and emissions in the food life cycle throughout all the stages. There are initiatives focused to inform consumers regarding the environmental burden of the food and promoting more environmentally friendly supply chains to reduce environmental and social impacts in different areas of interest, from land use or global warming to problems concerning food safety and losses [12].

1) Food losses and quality degradation:

Food losses are costly, affects society, environment and in terms of business can affect trade between actors and customer confidence, yet food losses are almost inevitable as food products have a limited lifetime and most goods are perishable.

Preventing safety issues in food is one of the most reliable pathways to prevent food loss and waste, and using technological innovation and improvements is one of the top measures to achieve it [13].

Food losses at the end of the supply chain, like in the household at the consumer, or retailers, are called food waste. Consequently, food loss is the removal of any food and its inedible parts from the supply chain at any stage for whatever use, no matter if it is for recovery or disposal.

Regarding food waste, probably the best definition has been stated in [14], which describes it as "the food that is appropriate for human consumption but it is discarded either before or after spoils, as a result from the negligence or a conscious decision to throw it away" [15].

The wastage of food is a matter when it comes to the situation of food security, sustainability, and climate change. Wastage is a recurrent issue in any supply chain, but food waste along the FSC is difficult to measure as it involves all actors of the FSC, and the causes are varied [16]. It is a consensus that this occurs principally at the end of the supply chain due to quality losses, reached the expiration date, or damages during the stage [17], [18].

Some of the quality problems related to food products have their root in relationship issues in the supply chain. A weak supply chain relationship between actors, suppose to be an important driving influence for suppliers to try to take advantage of other partners in the supply chain, so every actor needs to achieve a successful relationship to deliver a quality product to the end consumer [19]. That is why supply chain management has been arising as a discipline as it has been demonstrated that working as a network and increasing collaboration can deliver benefits, that individual approaches cannot bring [20], [21].

2) Environmental issues:

The environmental concerns caused by the activities related to FSC can be divided into direct and indirect impacts. Direct impacts come from resources and emissions consumed and caused by activities within the system boundaries considered in a supply chain. These resources are consequently linked to the use of raw materials, energy use, and other intermediate products necessary for carrying the actions within the involved processes.

On the other hand, indirect impacts in the FSC are considered as those from food produced and not eaten (food losses and waste). The impact is estimated at around 3.3 Gt CO₂ eq in carbon footprint terms, representing the third source of carbon emissions after the USA and China compared with direct country emissions [14], [22].

Manufactured or harvested non-eaten food is estimated to take up around 1.4 billion hectares of land, the equivalent of almost a third part of the total agricultural area in the world [14]. It has been also calculated that to ensure the 2050 population demand for food, its production needs to rise by 60%, but avoiding food waste would eliminate the need for such increase [14].

Environmental pressure has arisen to tackle a variety of sustainability concerns, mainly waste reduction and packaging reusing [23]. Such sustainability concerns should impact the FSC at the environmental level and the society (to different stakeholders) and influence the development of corporate social responsibility programs [24].

B. The fishery sector

Within the food sector, fisheries and aquaculture play an important role as food sources, nourishment, and income source of millions of people worldwide. In the last decade, thanks to globalization and international trade, fishery and aquaculture sub-sectors have become an essential player in the economic expansion and development for many countries and currently, it represents one of the greatest operating sections in the food industry [25]. The fishing activities employ almost 37

million people working directly worldwide, especially in less developed countries where it constitutes a predominant part as an income generator and food supplier [26].

In Latvia, fisheries have always played a crucial role in the economy. The national fishery and fish production activities are linked to traditions that have developed over time and still are based on local fish found in the Baltic Sea and Gulf of Riga [27]. By 2019, the fish production in Latvia accounted for 110200 tonnes of live weight [28], while the aquaculture sub-sector was responsible for 626.4 tonnes between fish and crustaceans.

In economic terms, the fisheries sector has maintained a positive trade balance, due to keeping the imports amounts under the exports consistently and with the exports growing through time. While in 2003 the total production value from the processing sector was worth € 134 million, in 2017 it was reported as € 150.9 million, and the total worth of exports was €206 million, €40 million more than imports [29] [30].

Most exported fish products and canned fish are commercialized inside the European zone, representing 68 % of the Latvian exports in this sector. Inside the European Union (EU), Denmark, Lithuania, Poland, and Estonia are the main buyers. This way, ready-to-eat or preserved fish accounts for the third part of Latvian exports to the EU [30].

Considering the relevance of the fishery sector in the EU and Latvia, and its impact on energy consumption, the bibliographic analysis presented in the next section focuses on links between energy consumption and potential EEM, and environmental impact evaluation across the fish supply chain.

III. METHODOLOGY

A bibliometric analysis was proposed to evaluate the state of the art of research studies conducted on the environmental impact evaluation of the fish product's supply chain in the European context. The main goal is to analyze the potential impact of implementing energy efficiency measures in the cold supply chain of fish products.

The VOSviewer[®] software was utilized to create and visualize the map. Scientific publication's keywords are used to construct a network. In this work, the items displayed are connected by co-occurrence that is gathered using bibliographic database files taken, in this study, from the Scopus database system.

The items displayed in a visualization map are the object of interest, and between any pair of them, links are created and displayed. These links represent the relationship between the items. A link between two keywords indicates a co-occurrence in a source. Such links have a strength score that is given by a positive numerical value, the higher the value, the stronger the link. A link's strength indicates the number of publications in which two terms occur together (i.e., co-occurrence). The items and their links, all together represent a network.

The bibliometric analysis was conducted by creating a search string in Scopus considering the keywords: "cold chain", "environmental impact", "energy efficiency", and "fish products". However, only 7 papers have been published with

these keywords linked in the abstract or intentionally mentioned by authors in the keywords section. From these papers, it can be noticed how none of them evaluates the environmental impact of potential EEM implemented in FSC. Nevertheless, some of them do assess the environmental impact of cold chains or the environmental impact of new technologies used in industrial fish production (see Table I).

TABLE I. PAPERS MATCHING STRING

Paper Title	Year	Ref
Sustainability, energy budgeting, and life cycle assessment of crop-dairy-fish-poultry mixed farming system for coastal lowlands under the humid tropic condition of India	2019	[31]
Environmental assessment of the Peruvian industrial hake fishery with LCA	2018	[32]
Life Cycle Assessment of a Commercial-Scale Freshwater Aquaponic System	2017	[33]
A set of sustainability performance indicators for seafood: Direct human consumption products from Peruvian anchoveta fisheries and freshwater aquaculture	2015	[34]
Edible protein-energy return on investment ratio (ep-EROD) for Spanish seafood products	2014	[35]
Life cycle assessment for environmentally sustainable aquaculture management: A case study of combined aquaculture systems for carp and tilapia	2013	[36]
Cradle to the retailer or quick-service restaurant gate life cycle assessment of chicken products in Australia	2013	[37]

As seen in Table I, most of the studies using LCA or sustainability analysis are performed on a single actor in the FSC [37]. Moreover, these papers do not assess the implementation of measures that may boost sustainability compared with the current scenarios, and the environmental changes they could represent.

IV. RESULTS AND DISCUSSION

The keyword "energy efficiency" was replaced in the searching string simply by "energy" while all other fields remained the same to expand the possible results. By doing so, 79 articles matching the search string were found published in the last decade. Using those 79 articles, the bibliographic analysis was conducted in VOSviewer[®].

A quick look at the diagram (see Fig. 1) shows how the most concurrent keywords found in the papers are "life cycle assessment", "life cycle analysis", "environmental impact", "fish", "aquaculture" and other keywords mainly related to impact categories and "sustainability". This is determined by the size of the characters displayed on the map. The more prominent the characters, the higher the weight of the item (keyword) is. In this case, the weight is given by the number of occurrences, meaning the number of publications the keyword appears at.

An example is presented in Fig. 1, using the keyword "environmental impact". This keyword has a total of 53 links, and 46 occurrences. Thus, the "environmental impact" keyword has 53 different co-occurrences with other keywords, appearing in 46 different papers. Moreover, the total link strength has a score of 441. The total link strength indicates the

total amount of co-occurrences with any other keyword in all the papers.

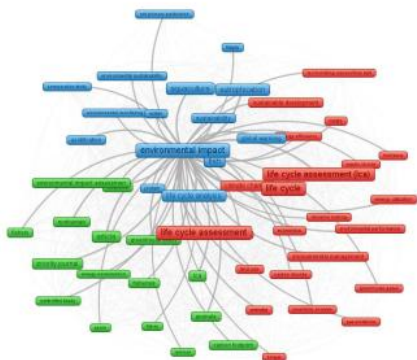

Fig. 1. Item analysis example.

The link strength example presented in Fig. 2, between “environmental impact” and “aquaculture” keywords, has a reported score of 21, meaning that this co-occurrence appears in 21 different documents from the total amount that create the network (79).

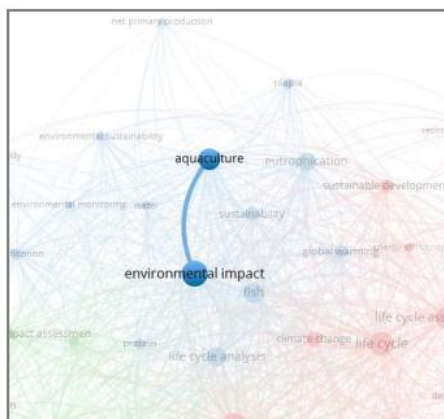

Fig. 2. Link strength analysis.

After reviewing the strength of each keyword, valued and weighted depending on the number of co-occurrences, ten main keywords were identified and presented in Table 2. The analysis of these keywords allows us to recognize that although the environmental impact in fish and aquaculture has been covered in the last years, the full supply chain for fish products linked with its impacts and EEM is not studied in detail.

TABLE II TEN MAIN KEYWORDS BY WEIGHT (OCCURRENCES)

Keyword			
	Links	Total link strength	Occurrences
Life cycle	53	477	48
Environmental impact	53	441	46
Life cycle assessment	53	445	46
Life cycle Assessment (LCA)	52	396	41
Aquaculture	51	330	33
Fish	53	321	33
Life cycle analysis	52	304	30
Eutrophication	51	289	27
Animals	48	186	16
Climate change	49	174	18

As it can be seen, most of the keywords are related to life cycle assessment methodology and some specific environmental categories such as climate change and eutrophication, which is consistent with both: current concern for global warming effects, and the impact of fisheries and aquaculture in local communities and ecosystems.

However, no keyword related to energy efficiency measures or evaluation appears in the list. Thus, it can be inferred that not many studies evaluating the impact of EEM on the environmental performance of fish supply chains are available at the moment. This gap can be an incentive for researchers to go into the topic of environmental and sustainability evaluation of FSC (fish) where EEM are undertaken to value the impact of such measures under a life cycle thinking approach.

V. CONCLUSIONS

Identifying hotspots in the full supply chain of a product is the first step in the process of achieving not only sustainability but also carbon neutrality, the main goal to reach by 2050 according to the green deal.

Several studies exist to understand the environmental impact of food supply chains, nevertheless, few have been undertaken for cold supply chains in the fish sector.

There is also a gap in data that aids to identify potential hotspots in FSCs, which can be seen as a stumbling block for the actors in the food industry not only at the environmental but also at the economic level, in the search for sustainability.

The results show there is a lack of studies on diagnosing the potential benefits or setbacks of implementing energy efficiency measures in actors across the food supply chains.

Considering this, the work here presented gains relevance, at a scientific and practical level, as fish supply chains and their related impact need to be understood fully to overcome the

different obstacles in achieving sustainability in the European industrial sector.

ACKNOWLEDGMENT

The contents of the paper are a part of the program project Improving Cold Chain Energy Efficiency (ICCEE). ICCEE has received funding from the European Union's Horizon 2020 research and innovation program under grant agreement No. 847040.

REFERENCES

- [1] FoodDrinkEurope, "FoodDrinkEurope launches latest Data & Trends in the European food and drink industry," no. October, p. 2018, 2018.
- [2] F. Monforti and J. F. Dallemand, "Energy use in the EU food sector: State of play and opportunities for improvement Energy from Waste in Croatia View project. 2015.
- [3] Zanoni et al., "Improving Cold Chain Energy Efficiency: EU H2020 project for facilitating energy efficiency improvements in SMEs of the food and beverage cold chains," 2020, doi: 10.18462/air.iccc.2020.292878.
- [4] Deloitte, "Energy Efficiency in Europe: The levers to deliver the potential," p. 80, 2016, [Online]. Available: <https://www2.deloitte.com/.../Energy-and-Resources/energy-efficiency-in-europe.pdf?0A>.
- [5] P. Thollander and J. Palm, "Efficiency in Industrial Energy Systems," 2013.
- [6] E. Cagno and A. Trianni, "Evaluating the barriers to specific industrial energy efficiency measures: An exploratory study in small and medium-sized enterprises," *J. Clean. Prod.*, vol. 82, pp. 70–83, 2014, doi: 10.1016/j.jclepro.2014.06.057.
- [7] D. Coulomb, "Refrigeration and cold chain serving the global food industry and creating a better future: two key IIR challenges for improved health and environment," *Trends Food Sci. Technol.*, vol. 19, no. 8, pp. 413–417, 2008, doi: <https://doi.org/10.1016/j.tifs.2008.03.006>.
- [8] S. J. James, C. James, and J. A. Evans, "Modelling of food transportation systems – a review," *Int. J. Refrig.*, vol. 29, no. 6, pp. 947–957, 2006, doi: <https://doi.org/10.1016/j.ijrefrig.2006.03.017>.
- [9] S. Mercier, S. Villeneuve, M. Mondor, and I. Uysal, "Time-Temperature Management Along the Food Cold Chain: A Review of Recent Developments," *Compr. Rev. Food Sci. Food Saf.*, 2017, doi: 10.1111/1541-4337.12269.
- [10] S. J. James and C. James, "Advances in the cold chain to improve food safety, food quality and the food supply chain," *Deliv. Perform. Food Supply Chain*, pp. 366–386, 2010, doi: 10.1533/9781845697778.5.366.
- [11] C. James, G. Purnell, and S. J. James, "A Review of Novel and Innovative Food Freezing Technologies," *Food Bioprocess Technol.*, 2015, doi: 10.1007/s11947-015-1542-8.
- [12] M. M. Aung and Y. S. Chang, "Traceability in a food supply chain: Safety and quality perspectives," *Food Control*, vol. 39, no. 1, pp. 172–184, 2014, doi: 10.1016/j.foodcont.2013.11.007.
- [13] M. V. Vilarinho, C. Franco, and C. Quarrington, "Food loss and waste reduction as an integral part of a circular economy," *Frontiers in Environmental Science*, 2017, doi: 10.3389/fenvs.2017.00021.
- [14] Food and Agriculture Organization of the United Nations (FAO), *Food waste footprint*, 2013.
- [15] B. Lipinski, C. Hanson, J. Lomax, L. Kitinoja, R. Waite, and T. Searchinger, "Reducing food loss and waste. Working Paper, Installment 2 of Creating a Sustainable Food Future," 2016.
- [16] B. Devin and C. Richards, "Food Waste, Power, and Corporate Social Responsibility in the Australian Food Supply Chain," *J. Bus. Ethics*, vol. 150, no. 1, pp. 199–210, 2018, doi: 10.1007/s10551-016-3181-z.
- [17] K. Liljestrand, "Logistics solutions for reducing food waste," *Int. J. Phys. Distrib. Logist. Manag.*, 2017, doi: 10.1108/IJPDLM-03-2016-0085.
- [18] K. Verghese, H. Lewis, S. Lockrey, and H. Williams, "Packaging's Role in Minimizing Food Loss and Waste Across the Supply Chain," *Packag. Technol. Sci.*, 2015, doi: 10.1002/pts.2127.
- [19] G. Liu, "The impact of supply chain relationship on food quality," *Procedia Comput. Sci.*, vol. 131, pp. 860–865, 2018, doi: 10.1016/j.procs.2018.04.286.
- [20] C. R. Carter, D. S. Rogers, and T. Y. Choi, "Toward the theory of the supply chain," *J. Supply Chain Manag.*, 2015, doi: 10.1111/jscm.12073.
- [21] U. Jüttner and S. Maklan, "Supply chain resilience in the global financial crisis: An empirical study," *Supply Chain Manag.*, 2011, doi: 10.1108/13598541111139062.
- [22] H. Zhao, S. Liu, C. Tian, G. Yan, and D. Wang, "An overview of current status of cold chain in China," *Int. J. Refrig.*, vol. 88, pp. 483–495, 2018, doi: 10.1016/j.ijrefrig.2018.02.024.
- [23] M. Vanderroost, P. Ragaert, F. Devlieghere, and B. De Meulenaer, "Intelligent food packaging: The next generation," *Trends in Food Science and Technology*, 2014, doi: 10.1016/j.tifs.2014.06.009.
- [24] R. Alkerman, P. Farahani, and M. Grunow, "Quality, safety and sustainability in food distribution: A review of quantitative operations management approaches and challenges," *OR Spectr.*, 2010, doi: 10.1007/s00291-010-0223-2.
- [25] FAO, *The State of Food and Agriculture 2019. Moving forward on food loss and waste reduction*, 2016.
- [26] L. Proskina, I. Pilvere, A. Nipers, and M. Silovs, "Characteristics of the fishing industry in Latvia," 19th Int. Sci. Conf. "Economic Sci. Rural Dev. 2018". Bioeconomy. Financ. Taxes. Home Econ. New Dimens. Dev. Soc., vol. 49, no. 49, pp. 56–64, 2018, doi: 10.22616/esrd.2018.118.
- [27] I. Biuksane and I. Judrupa, *Evaluation of the competitiveness of fisheries sector cluster*, vol. 2, 2016.
- [28] Central Statistical Bureau of Latvia, "Fish Catch," 2017, http://data1.csb.gov.lv/pxweb/en/lauks/lauks_zvejn_ikgad/rxid=d8284c56-0641-451c-8b70-b6297b58f464&tablelist=true (accessed Feb. 09, 2021).
- [29] Food and Agriculture Organization of the United Nations (FAO), "Country profile," 2005. [Online]. Available: <http://www.fao.org/fi/oldsite/FCP/en/LVA/profile.htm#:~:text=Structure of fisheries sector&text=Latvia has a fleet of,Riga fleet%3B and coastal vessels,&text=Catch from the Gulf of,for Latvia's fish processing industry>.
- [30] Eurofish International Organisation, "Overview of the Latvian fisheries and aquaculture sector," Member countries, 2016, http://eurofish.dk/~efweb/index.php?option=com_content&view=article&id=123%3Aturkey&catid=37&Itemid=59 (accessed Feb. 08, 2021).
- [31] V. Paramesh et al., "Sustainability, energy budgeting, and life cycle assessment of crop-dairy-fish-poultry mixed farming system for coastal lowlands under humid tropic condition of India," *Energy*, 2019, doi: 10.1016/j.energy.2019.116101.
- [32] A. Avadi, R. Adrien, V. Aramayo, and P. Fréon, "Environmental assessment of the Peruvian industrial lake fishery with LCA," *Int. J. Life Cycle Assess.*, 2018, doi: 10.1007/s11367-017-1364-1.
- [33] S. E. Boxman, Q. Zhang, D. Bailey, and M. A. Trotz, "Life Cycle Assessment of a Commercial-Scale Freshwater Aquaponic System," *Environ. Eng. Sci.*, 2017, doi: 10.1089/ees.2015.0510.
- [34] A. Avadi and P. Fréon, "A set of sustainability performance indicators for seafood: Direct human consumption products from Peruvian anchoveta fisheries and freshwater aquaculture," *Ecol. Indic.*, 2015, doi: 10.1016/j.ecolind.2014.09.006.
- [35] I. Vázquez-Rowe, P. Villanueva-Rey, M. T. Moreira, and G. Feijoo, "Edible protein energy return on investment ratio (ep-EROI) for Spanish seafood products," *Ambio*, 2014, doi: 10.1007/s13280-013-0426-2.
- [36] R. Mungkung, J. Aubin, T. H. Pihadi, J. Slembrouck, H. M. G. Van Der Werf, and M. Legendre, "Life cycle assessment for environmentally sustainable aquaculture management: A case study of combined aquaculture systems for carp and tilapia," *J. Clean. Prod.*, 2013, doi: 10.1016/j.jclepro.2013.05.029.
- [37] J. Bengtsson and J. Seddon, "Cradle to retailer or quick service restaurant gate life cycle assessment of chicken products in Australia," *J.*

Presenter's biography:

Fabian Diaz holds a bachelor in Chemical Engineering, and a Master degree in Environmental Science. He has more than ten years of experience in the chemical and energy sectors, and 2 more years working as researcher for the Institute of Energy and Environmental Systems at Riga Technical University where he has been focus on the Life Cycle Sustainability of different sectors.

Article 3: Environmental and economic life cycle evaluation of potential energy efficiency measures on Latvian fish supply chain.



Environmental and economic life cycle evaluation of potential energy efficiency measures on Latvian fish supply chain

Fabian Diaz*, Lolita Koiro, Francesco Romagnoli

Institute of Energy Systems and Environment, Riga Technical University, Azenes iela 12/1, Riga LV-1048, Latvia

ARTICLE INFO

Keywords:

Cold supply chain
Energy efficiency measures
Life cycle cost
Circular economy
Sidestream valorization

ABSTRACT

The food industry consumes a significant amount of energy, and it is responsible for 20 to 30 percent of global greenhouse gas emissions, with cold supply chains absorbing about 70 percent of the energy expended in post-agriculture food systems. Despite this, some gaps remain in the sector when looking toward identifying energy consumption hotspots and evaluating the impact of energy efficiency measures across the entire supply chain. This study implements an environmental Life Cycle Assessment and a Life Cycle Cost analysis to assess a Latvian fish cold supply chain and implement two energy efficiency measures in different stages. Specifically, a fish waste valorization scenario via anaerobic digestion processes, and a scenario implementing a photovoltaic system, are considered. Both strategies proved economically feasible and delivered environmental benefits at different levels than the defined baseline scenario. The energy production from fish waste showed the best economic evaluation performance, with an internal rate of return of 14.4 percent.

1. Introduction

In recent decades instrumental meteorological observations identified the most rapid changes in climatic parameters in history. As a result, temperatures in the 21st century are predicted to rise faster than before in the event of all assessed greenhouse gas emissions (GHG) scenarios (Rogelj, 2018). This trend will affect society and numerous businesses and economic sectors. Consequently, governments are adopting measures to enhance their capacity to adapt and contribute to climate change mitigation and its repercussions' sustainability within the scope of the Paris Agreement. (United Nations, 2015).

In the European Union (EU), GHG related to agricultural processes increased from 9.9% in 1990 to 10.3% by 2019, despite the actual emissions falling 20.9% in that period (Eurostat, 2021). The food industry and food supply chains (FSC) are responsible for 20–30% of GHG emissions worldwide (Santonja et al., 2019) due to the significant resources needed for food production, foodstuff supply chain, and food waste (Mena et al., 2011). It is estimated that 88–100 million tons of food are wasted each year, with an associated economic impact appraised at 143 billion Euros in 2012 (Stenmarck et al., 2016), which makes food waste a fundamental concern within the food industry.

Actors along the FSC are working on improving their energy consumption by refining their energy efficiency towards sustainability. Energy audits according to Art. 8 of the EU Energy Efficiency Directive (2012), EC 2012/27/EU (2012), European Parliament (2018) re-

vealed a potential primary energy reduction of 26% in the EU food and beverage sector if all technically possible and practicable energy-saving options are implemented regardless of their economic viability. (Chan and Kantamaneni, 2015). However, energy audits only provide a snapshot of the current state because they do not account for the required expenditures and their potential contribution to the long-term sustainability of whole supply chains.

The main barriers to carrying out potential energy efficiency measures (EEM) are low financing, lack of awareness, lack of knowledge, and unsuitable indicators and tools that dampen the efforts to select the best cost-effective measures (Thollander and Palm, 2013a; Cagno and Trianni, 2014). Moreover, according to (Thollander and Palm, 2013b; Cagno and Trianni, 2014), the effects of various EEMs depend on the industry sector and the actor adopting them. Consequently, EEM must be tailored to the unique situation and environment.

Population growth has increased the demand for fresh food, necessitating more creativity and technology to overcome capacity and infrastructure limitations. These elements would help reduce potential hazards (e.g., supply chain disruptions and lack of resources) and improve customer food quality. (FAO, 2013; Zhao et al., 2018a). In this context, despite its higher energy consumption in the FSC, the cold chain is one of the technological methods that help achieve this objective.

However, cold chains' main drawback is their energy intensity. Almost 70% of the total energy used in food systems occurs in post-agriculture processes, including transport, processing, packaging, storage, and distribution to retailers. (Han et al., 2021). Thus, providing

* Corresponding author.

E-mail address: fabian-andres.diaz-sanchez@rtu.lv (F. Diaz).

<https://doi.org/10.1016/j.fufo.2022.100203>

Received 31 December 2021; Received in revised form 31 October 2022; Accepted 5 November 2022

2666-8335/© 2022 The Authors. Published by Elsevier B.V. This is an open access article under the CC BY-NC-ND license (<http://creativecommons.org/licenses/by-nc-nd/4.0/>)

a comprehensive yet consistent set of evaluation tools is vital for a successful and effective decision-making process regarding energy efficiency initiatives, both financially and environmentally. Furthermore, consumers need clean, safe, nutritious, and ecologically responsible products (Leandro et al., 2021).

In the food and beverage industry, the cold supply chain (CSC) plays a crucial role in ensuring the quality and safety of food products. However, direct and indirect emissions negatively influence the environment due to the increased need for refrigeration. (FAO, 2013; Zhao et al., 2018b; Wan, 2011). To reduce energy consumption in food CSC, stakeholders must comprehend and identify energy-intensive phases to implement the most effective methods. This analysis demands a holistic strategy that avoids transferring the burden amongst supply chain actors and determines the appropriate systemic adjustments (Musa et al., 2014), consistent with the proposed Sustainable Development Goals (United Nations, 2019).

FSCs are complex and dynamic systems due to the various intervening actors, fluctuating environmental circumstances, and transit product types, necessitating customized study. Fishing is a substantial source of revenue and food in developing countries, where it employs 37 million people directly. (FAO, 2016), (Proskina et al., 2018). By 2019, the EU reported 75 thousand vessels in operation only in Europe (Eurostat, 2021), making the EU the fifth major fish producer globally, with almost 3.2% of global production derived from fisheries with 80% of the share, and aquaculture with 20% of share production (European Commission, 2016).

Under the EU Green Deal plan, the EU Circular Economy Strategy aims to optimize energy efficiency in the fish and seafood industry (Ruiz-Salmón et al., 2021) from a supply chain perspective. This comprehensive viewpoint is vital for promoting, on the one hand, a more consistent data collection and, on the other, better control of fishing activities and downstream conversion and manufacturing processes. Moreover, this change should improve the efficiency of decision-making processes, adjust products to consumer demand, and boost the system's circularity (e.g., reduce waste or improve recycling).

The Life Cycle Assessment (LCA) and life cycle costs (LCC) methods can provide a quantitative background to assess measures intended to enhance the energy efficiency, among others. LCA and LCC are recognized as consistent scientific tools for environmental and economic impact assessments. During the last decade, many LCA-based studies have been published (Vázquez-Rowe and Benetto, 2014; Ziegler, 2016; Ruiz-Salmón et al., 2021) focused on different fish or seafood products, either frozen or chilled. From an LCA standpoint, these evaluation studies identified significant gaps and deficiencies in the overall CSC of fish and seafood products. First, there is a lack of comprehension of the effects induced by fishing activities, except for those that pose biological problems. Second, there is a quantification of the principal driver of the environmental impact covered in LCA (such as fuels and logistics). Still, the analysis does not consider significant system boundaries (i.e., Cradle-to-grave or Cradle-to-cradle). In addition, we observed a deficiency in LCA studies integrating fish and seafood with economic enablers to comprehend their financial implications.

As a member of the EU, Latvia receives financial support and aid from other financial instruments to implement the Common Fisheries Policy (European Commission, 2016; Proskina et al., 2018), which primarily focuses on EU-set priorities but is tailored to each member state's sector. (Biuksane and Judrupa, 2016). By 2019, fish production in Latvia accounted for 110,200 tons of live weight, while the aquaculture sub-sector was responsible for 626.4 tons between fish and crustaceans (Institute of Food Safety et al., 2019). Among the most prevalent types of fish goods in Latvia, frozen, salted, smoked products, preserves, ready-to-eat products, and sanitized canned fish are the most prevalent. Latvian fish processors rely primarily on sea species, accounting for a minuscule proportion of freshwater species. (OECD, 2021).

The CSC's downstream processes play a crucial role in the Latvian fish industry activities (Proskina et al., 2018). Evaluating the required

refrigeration processes and fish quality to understand how sustainably the EU strategies and EEM solutions could be implemented is essential. In addition, a comprehensive perspective should be taken, focusing on the three key pillars of sustainability. This work implements a holistic review of the impacts on the Latvian fish supply chain to complement technical evaluations of the cross-sectoral nation assessment (Proskina et al., 2018), considering the sectors' relevance to the Latvian economy.

In this perspective, in this study, methods for assessing the environmental and economic impact of EEMs are used to identify potential thresholds, trade-offs, or bottlenecks of CSC of fish products with a particular emphasis on the Latvian context. This study employs LCA and LCC methodologies to evaluate a baseline scenario for chilled Latvian cod and investigate the implementation of two energy measures along the CSC. Its results would assist supply chain managers in making more prudent investment and environmental decisions. (Diaz et al., 2022). The study also emphasizes the significance of analyzing each stage of the CSC for fish-based goods, identifying environmental and economic "hot spots" for specific environmental impact categories or economic indicators.

2. Materials and methods

2.1. Life Cycle Assessment (LCA)

This study uses the LCA methodology as a standardized procedure able to assess the environmental impacts of the proposed product system, including the specific unit processes in a gate-to-gate approach following the ISO 14,044:2006 Standards (ISO, 2006). In this work, we use an attributional LCA to evaluate a product's ecological implications rather than to understand its effect on background systems and market constraints. We use the IMPACT 2002+ method (Joliet et al., 2003) to perform the environmental profiling of the proposed model. This method has the advantage of delivering results both at mid-point impact categories - as recommended by the ISO Standards 14,044 (ISO, 2006) - and at end-points categories (damage categories), which "are an indicator of quality changes in the environment" (Joliet et al., 2003). This method was preferred to other end-point methods because it provides Climate Change as a standing-alone damage category, which was considered a relevant aspect for the target groups addressed in this study.

SimaPro 9.1 software developed by Pré Consultants (Goedkoop, 2016) and Ecoinvent 3.6 (Wernet et al., 2016) supported the data processing for creating the LCA model and evaluating the overall environmental impact using the IMPACT 2002+ method (Humbert, 2002).

2.2. Supply chain description: a baseline scenario

The proposed baseline scenario considers a business-as-usual case for a CSC within the Latvian context, assuming Codfish as a resource further exported to other countries in the European Economic Area. A literature review supported the definition of the hypothetical baseline scenario primarily based on LCAs studies of fish products within the European context (Claussen et al., 2011; Hognes et al., 2011; Hoang et al., 2016; Maiolo et al., 2020).

For the CSC under evaluation, the port of arrival for fishing vessels has been assumed at Ventspils, as it is one of Latvia's most prominent and well-known for its traditional fishing activities. In addition, we adopt that in Ventspils, a local processor is responsible for the processing activities necessary to produce packaged filleted cod. According to the waste management scenario from the Ecoinvent database, fish waste in the baseline scenario is considered to be processed as slaughterhouse waste for tallow manufacturing (Wernet et al., 2016), and no wastes occur from this point downstream in the supply chain.

Expanded polystyrene (EPS) boxes with a capacity of 26 kg per box are used as packing material. The total distance traveled is calculated using available road data from open sources such as Google Maps®,

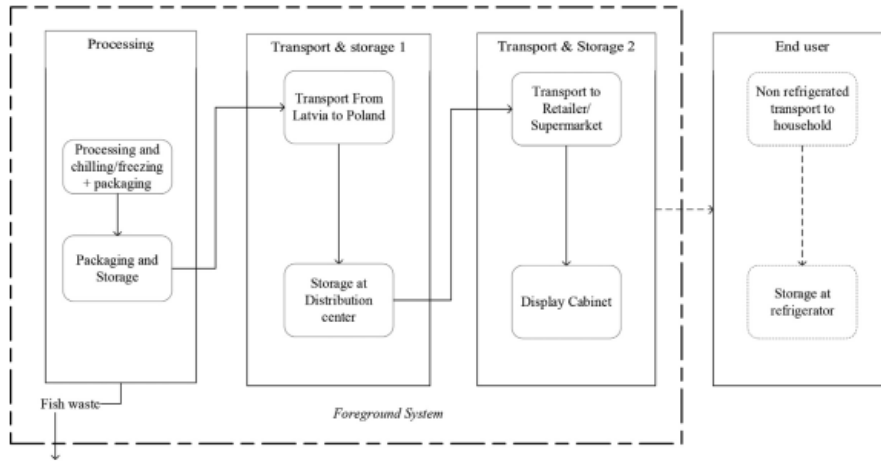

Fig. 1. Cold supply chain system boundaries.

and a truck to match the intended payload (23,400 kg) is selected (> 16 tons).

The environmental condition for transporting the fish is $-2\text{ }^{\circ}\text{C}$ when assuming a superchilled cooling technology ($< 0\text{ }^{\circ}\text{C}$) and $+2\text{ }^{\circ}\text{C}$ for chilled conditions. The diesel consumption for the auxiliary unit was calculated at 3.0 kg/h. The assumed refrigerant is R-134a, with an annual precharge of 6.5 kg and a leakage of 10% per year. The SimaPro software® was used to simulate the model creating the foreground system and taking the background processes from the Ecoinvent database 3.6 (Wernet et al., 2016).

2.3. LCA goal and scope

This study employs current conditions and technologies for supply chain operations and examines the relevant and actual flows of materials and energy within the product system, extending the boundary for assessing the impacts and advantages of the selected EEMs. The selected Functional Unit (FU) is 1.0264 kg of final product placed on the shelves at the retailer stage. This FU accounts for a 1.0 kg cod fish fillet and 0.0264 kg packaging material.

The system boundaries, specifically for the product system under evaluation, are presented in Fig. 1. This work uses a cradle-to-gate approach without considering the use stage for the food product. The decision relies on although the phase related to the storage and consumption of food in households is of high importance for evaluating food losses and quality degradation, too many variables can affect the overall environmental performance of such a stage. Moreover, EEMs are challenging to implement in the household stage from an FSC managerial standpoint. The fishing activity (including transport to shore) is also excluded from the study. Although it may deliver a high environmental impact on the whole system, EEMs are considered only for foreground processes.

2.4. Life cycle inventory

Processing: The processing phase consists of two primary steps: (i) processing and packaging and (ii) storage before transport. The processing consists of fish gutting, head removal, bone removal, and filleting, leaving 0.74 kg of fish waste that can be used as a feedstock for side-streams valorization processes (Hoang et al., 2016). This study implies that fish filleting, beheading, and gutting are performed manually. The energy expenditure for superchilled products is linked to the contact blast chiller (CBC), which should guarantee a temperature of $-2\text{ }^{\circ}\text{C}$

thanks to the ice formed within and across the fish fillet (Hoang et al., 2016).

This work uses data presented in Table 1 from Hognes et al. (2011), Hoang et al. (2016) for specific calculations and assumptions in the foreground system. The electricity for storage was assumed as 1.2 kJ/kg of fillet for a total storage time of 24 h (Brown, 2014), and the energy expenditure for the CBC was 72 kJ/kg of fish fillet to effectively bring the temperature down to $-2\text{ }^{\circ}\text{C}$ (Hoang et al., 2016).

Transport to the distribution center: This phase assesses the transit of cod fillets from Ventspils, Latvia, to Warsaw, Poland, where the primary warehouse is located. Poland has been selected as the final market for the modeled product as one of the most frequent destinations for Latvian fish products.

The payload was settled according to Hoang et al. (2016), where 23,400 kg of fish fillet (without considering the box's weight) was transported in a 28 tons lorry. After leaving the producer facilities, the cod fillets are transported across 845 km until reaching Warsaw.

Using available data (Sharifzadeh et al., 2015), an average speed of 60 kms per hour was utilized to calculate the time required to reach Warsaw without stopping (14.1 h). The background process selected from the Ecoinvent database accounts for the vehicle's fuel consumption, combustion, and other pollutants, such as those caused by worn tires and the vehicle's manufacture.

Due to the size of the lorry, an auxiliary diesel refrigeration unit is assumed to be mounted in the cargo area to fulfill the cold necessities. Considering the values in Tassou et al. (2012), and by interpolation, to a temperature of $-20\text{ }^{\circ}\text{C}$, the diesel consumption (only for refrigeration) was estimated at 2.5 L/h. With a diesel density of 0.832 kg/L, mass consumption of 2.08 kg/h is used, which turns out in 0.001252 kg per FU after normalization.

Storage at distribution center: Once the fish have reached the distribution center, the product is stored for 24 h under similar cold storage conditions as in the previous storage activity. (Hoang et al., 2016). From this point down the supply chain, it is assumed the transport and storage conditions occur at $+20\text{ }^{\circ}\text{C}$, corresponding to typical chilled food products (Claussen et al., 2011; Hoang et al., 2016).

Transport to the retailer: The cod fillets are transported by a 7.5-ton lorry for 2.9 h (173 km) from Warsaw to Lublin at $+2\text{ }^{\circ}\text{C}$. The diesel consumption and refrigerant leakage are calculated accordingly.

Storage at the retailer: In this study, it is anticipated that Cod fillets are displayed for an average of seven days in open-fronted, multi-deck cabinets, a piece of equipment for chilled goods that typically operates at

Table 1
Normalized data for the processing stage.

Material	Value	Unit	Ecoinvent Ref. (APOS)
Processing			
Inflows:			
Whole fish (cod)	1.74	kg	-
Packaging material (EPS)	0.0264	kg	Polystyrene production RER
Electricity for CBC	72	kJ	Electricity, medium voltage, LV
Electricity for storage	1.2	kJ	
Outputs:			
Fish waste	0.74	kg	Slaughterhouse waste, market
Fish fillet product	1.0264	kg	-
Transport to Distribution Center			
Transport	0.867	tkm	Lorry 16–32 ton EURO 5, RER
Diesel consumption (refrigeration unit)	0.001252	kg	Diesel, burned in electric generating set
Refrigerant	1.56E-7	kg	Operation, reefer, cooling, R134a
Storage at Distribution Center			
Electricity for storage	1.2	kJ	Electricity, medium voltage, PL
Transport to Retailer			
Transport	0.178	tkm	Lorry 16–32 ton EURO 5, RER
Diesel consumption (refrigeration unit)	0.000258	kg	Diesel, burned in electric generating set
Refrigerant	3.22E-8	kg	Operation, reefer, cooling, R134a
Storage at Retailer			
Electricity for storage	0.046	kWh	Electricity, medium voltage, PL

5 °C. According to Hoang et al. (2016), this type of cabinet has an energy consumption of 10.4 kWh/m² per day, considering a display area of 5 m² and a total volume capacity of 5 m³.

Approximately 65% of the gross capacity is operational, but only 50% is packed with food items. (Hoang et al., 2016). A density of 500 kg/m³ of packed cod fillets is assumed, resulting in a total of 812.5 kg stored per cabinet. This results in total energy consumption of 36.4 kWh per cabinet with a net capacity of 812.5 kg cod fillets. The resulting normalized energy consumption is 0.046 kWh per FU.

2.5. Scenarios with energy efficiency measures

Two energy efficiency measures are investigated based on circular economy and industrial symbiosis. The first scenario (*EEM-1*) models anaerobic digestion in conjunction with a heat and power cogeneration plant, while the second scenario models a photovoltaic plant erected at the retailing facility with the capacity to supply 20% of the electricity usage (*EEM-2*).

2.5.1. Waste-to-Energy (*EEM-1*)

The European Commission has raised its interest in food waste valorization primarily through recycling secondary raw materials and recovering and reusing biomass according to the pyramid of value as a society must minimize food waste to transition to a circular economy (Commission, 2011; McDowall et al., 2017). Different assessment tools, e.g., Life Cycle Assessment and Life Cycle Cost, can be essential for calculating the intended technological routes' environmental and economic feasibility (Di Maria, Eyckmans and Van Acker, 2018; Zhang et al., 2020).

There are currently two main technological processes for food waste valorization in Europe: composting and biogas production (Fieschi and Pretato, 2018a). However, individual studies are conducted depending on the food typology for industrial symbiosis expansion, allowing a large share of food waste to go into sidestream valorization pathways (Yasin et al., 2013; Fieschi and Pretato, 2018b; Mahmood et al., 2019).

In the alternative scenario *EEM-1*, a fish waste valorization is proposed by transforming fish wastes at the processing stage into biogas via anaerobic digestion (AD). Biogas is further used in a cogeneration of heat and power (CHP) unit, a widely used technology in

Latvia (Central Statistical Bureau of Latvia, 2019). According to the data presented by (Greggio et al., 2018), a biomethane production of 361 Nm³/ton_{VS} (i.e., VS = volatile solids) can be achieved when fish wastes are co-digested with other substances, such as manure residues in a 1:1 ratio. This feedstock composition found an 84% higher yield than the AD of fish wastes alone (Vivekanand et al., 2018). Also, the percentage of biomethane in the biogas obtained after AD was 75% (Greggio et al., 2018), which can be considered a high biogas concentration. We can confidently conclude that the total energy production per kilogram of fish fillet delivered at the supermarket (defined as FU in this work) can reach values of 0.615 kWh/FU. A 160 kW CHP plant is included as an input in the processing stage to model the construction stage of such infrastructure, consistent with small-medium fish processors. The resultant thermal and electrical output was recorded as an "avoided product" (PRE Consultants, 2008), replacing traditional heat and power generation for the national electric grid and district heating systems.

2.5.2. Electricity production from a PV system (*EEM-2*)

The second alternative scenario (hereafter referred to as *EEM-2*) evaluates a photovoltaic (PV) system installed at the retailer stage of the modeled supply chain. This analysis assumes that the system's installed capacity would supply 20% of the supermarket's electricity needs.

In the *EMM-2*, a value of 0.0358 kWh of electricity is established, considering the PV system supplies 0.0092 kWh, providing the necessary power for seven days of storing the fish product. To calculate the energy potential, a 3 kW peak PV system positioned in an integrated building assembly was evaluated (due to limitations in the Ecoinvent database, this is the smallest available PV system). For such calculations, the European Commission's web-based tool was employed (European Commission, 2020), and the corresponding data are provided in Annex 1. The analyses were performed considering the supermarket's location in Lublin (Poland).

2.6. Life cycle cost (LCC)

The Life Cycle Cost section was created utilizing a conventional LCC (C-LCC) evaluation to analyze the various EMMs conducted compared to the baseline scenario. C-LCC is the method used to analyze the life cycle cost of an individual actor in the supply chain. This evaluation focuses

on actual and internal expenses, ignoring end-of-life costs, which other parties typically bear during a product's life cycle. This is the standard strategy manufacturers and customers take for conventional economic analysis. The C-LCC can be conducted without an LCA because their outcomes and methodologies are not linked. (Hunkeler et al., 2008).

2.7. LCC considerations

2.7.1. EEM-1

Typically, for biomass technologies, the share of the feedstock cost in the total Levelized Cost of Electricity (LCOE) ranges between 20% and 50% (International Renewable Energy Agency, 2020). In this scenario, the two feedstocks (i.e., fish waste and pig manure) are coming as wastes from other industrial processes, thus considered environmentally and costly, burden-free. Transport costs to the anaerobic digestion site are not included in this scenario. It is assumed that the bioreactors are placed near the fish processing plant.

This study takes the total installed costs for the proposed scenario from the latest IRENA Costs report (International Renewable Energy Agency, 2020). An average weighted capital cost of 3435 €/kW was assumed in this study, with a capacity factor of 90%, which corresponds to the average CHP plants in Europe for 2019 (International Renewable Energy Agency, 2020). A facility with a total installed capacity of 160 kW was assumed, in line with the proposed LCA. A 25-year lifespan was predicted, with a capacity factor of 7512 h/year and annual energy output of 1202 MWh.

The assumed fixed Operations and Maintenance (O&M) costs consist of labor, insurance, planned maintenance, and expected replacement of plant elements, such as boilers, gasifiers, feedstock handling equipment, and other parts. O&M costs account for a range between 2% and 6% of the total installed costs per year; this study assumed a value of 4%.

Variable O&M costs have an average value of 0.0043 €/kWh and are considered low for bioenergy power plants compared to fixed O&M costs (International Renewable Energy Agency, 2020). The maintenance costs (replacement of parts and additional repairing costs) are the main elements of variable O&M costs, and non-biomass fuel costs, such as disposal of ashes, are also included.

Regarding the financial conditions, the OECD recommends an expected rate of return of 7.5% for utility-scale projects (International Renewable Energy Agency, 2020). The average inflation for the last five years in Latvia was used (1.7%) for calculating the Weighted Average Cost of Capital (WACC) (Statista, 2021). We assumed an equity share of 30% and an interest rate of 5% for the loan. Finally, the electricity price was set at 0.1423 €/kWh (Statista, 2021), while the average thermal energy price in Latvia was 52.38 €/MWh (Baltic News Network, 2020).

2.7.2. EEM-2

This work adopts a total installed cost of 865 EUR/kW, equivalent to the global weighted average total installed cost in 2019 (International Renewable Energy Agency, 2020). Given that these prices are for commercial PV systems with capacities of up to 500 kW, a total installed capacity of 300 kWp is assumed, which corresponds to a middling capacity for the retail sector (IRENA, 2018).

Nowadays, O&M costs can represent up to 20–25% of the LCOE within the EU context (IRENA, 2018). Average utility-scale O&M costs in Europe are 8.7 €/kW per year (International Renewable Energy Agency, 2020). In this scenario, we make the following assumptions: an LCOE of 0.105 €/kWh (International Renewable Energy Agency, 2020) and a total annual energy production of 307,802 kWh (European Commission, 2020). For the economic evaluation of the EEM-2, an electricity price of 0.14 EUR/kWh was used, applying the latest data available for electricity prices in Poland (Statista, 2021).

The financial structure was built on inflation statistics from Poland and basic economic models. The OECD-recommended rate of return

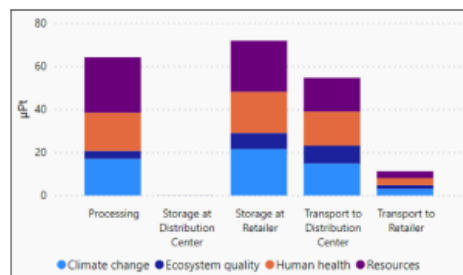

Fig. 2. Single score results for the baseline scenario.

of 7.5 percent was utilized in addition to a subsidy of 0.05 euros per kilowatt-hour produced, which given the government incentives for adopting Renewable Energy Sources, can be deemed standard.

3. Results and discussion

The LCA results at midpoint categories disaggregated by unit processes are presented in Annex 2. Fig. 2 illustrates the results at the endpoint category level in an ecological score (i.e., Pt as average impact per EU person per year). The identified hotspots are the storage at the supermarket/retailer, the processing stage, and the transport under superchilled conditions, especially in the areas of the use of resources, human health, and climate change. The sub-activities or flows with most of the environmental burden within these processes are the electricity consumption at the retailer, the vehicle utilization for transport to the distribution center, the slaughterhouse waste treatment, and the use of the chosen packaging material for the fish fillets at the processing stage. Compared with other steps in the CSC, the low impact delivered by the transport to the retailer (also known as food miles) is in line with the discussion summarized in (Coley et al., 2013).

From an overall environmental perspective, waste valorization from the processing stage could represent an opportunity to decrease the total burden of the CSC. Implementing renewable energy technologies and interventions on electricity consumption should provide economic benefits at the supermarket. The alternative scenarios, defined as EEM-1 and EEM-2, focus on these aspects.

3.1. Life cycle impact assessments of EEMs

3.1.1. Energy recovery from biowaste (EEM-1)

Comparing the performance of the two proposed scenarios reveals that implementing EEM-1 mitigates the environmental impact of the processing stage. Fig. 3a shows the stacked impact results for each scenario in the different damage categories. In contrast, Fig. 3b displays the impacts per process/material in the baseline compared with the aggregated effects of inputs in the EEM-1.

Compared to the baseline scenario, where the fish waste treatment accounts for over 95% of all the ecological toll in the processing stage (see Fig. 3b), the analyzed EEM-1 provides environmental benefits and fully compensates for the ecological loads of other processes (see Fig. 3c). Implementing the EEM-1 can potentially create avoided impacts on climate change and human health while drastically reducing effects on ecosystem quality and resource use.

3.1.2. Electricity production from a PV system (EEM-2)

The weighted results for the entire CSC indicate that a PV system integrated into the store and supplying 20% of the total energy requirement would result in an environmental score of 58.06 Pt at the retailer stage. Fig. 4 shows the single score results for all three scenarios eval-

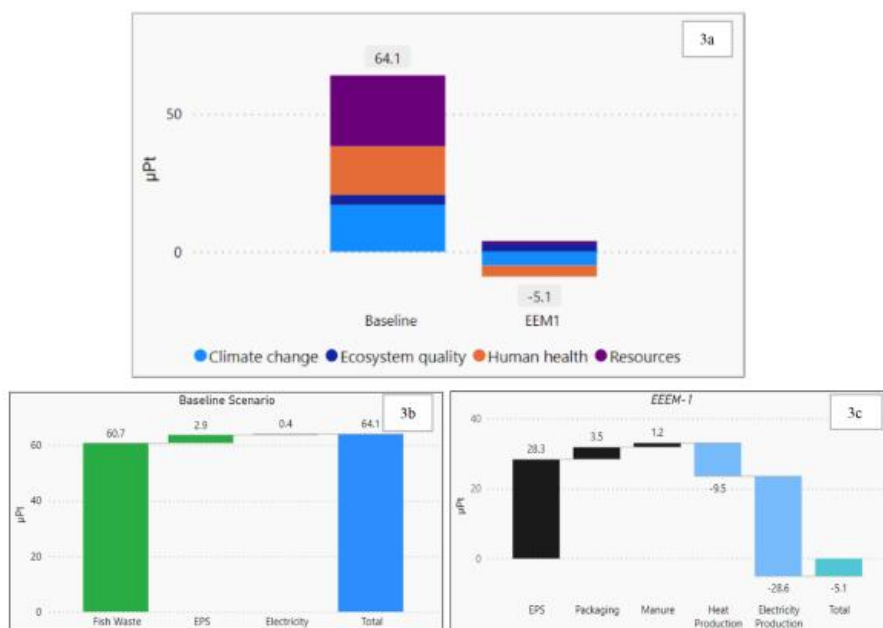

Fig. 3. (a) Single score comparison of both scenarios in the processing stage. (b) and (c) Shares per input in the baseline and *EEM-1* scenarios for the processing stage.

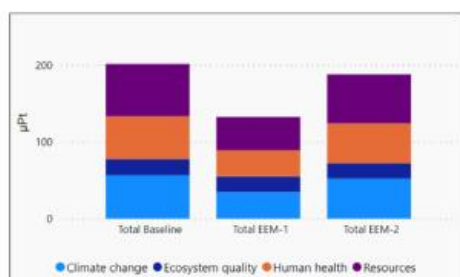

Fig. 4. Single score comparison results for the three supply chain scenarios.

Table 2
Single score results for all three CSC scenarios.

Damage category	Unit	Total Baseline	Total <i>EEM-1</i>	Total <i>EEM-2</i>
Total	μPt	201.62	132.46	187.93
Human health	μPt	55.92	34.19	52.38
Ecosystem quality	μPt	21.03	20.24	19.68
Climate change	μPt	56.36	34.40	52.17
Resources	μPt	68.32	43.63	63.70

uated, with the baseline scenario having the highest impact, followed by the scenario where the *EEM-2* is implemented. In the reviewed context, the commissioning of the *EEM-1* has the most significant potential to reduce the total environmental outcome caused by the fish supply chain.

Table 2 shows the detailed environmental profile based on the total normalized and weighted sum of each damage category according to the IMPACT 2002+ method. While the *EEM-2* would result in a total saving

of 13.7 μPt (6.8%), the *EEM-1* could potentially reduce the impacts by 69.2 μPt (34.3%) in this CSC.

3.2. Sensitivity analysis for the LCA study

This work performs a sensitivity analysis to determine the impact of changes in specific input parameters compared to the main study output as a single score result. The two chosen parameters are the transport distance from the processing plant to the central warehouse and the energy consumption at the processor unit process, as they were identified as the ones impacting the most the overall environmental performance. These variables were selected considering their impact on the baseline scenario (see Fig. 2). The transport to the distribution center is responsible for more than 25% of the total mark. In comparison, the energy consumption at the processing stage does not appear under the cut-off criteria of 5%. Hence, this sensitivity analysis also works as a consistency check.

The scenarios considered for the sensitivity analysis are the decrease and increase of 5, 15, 30, and 50 percent in each selected parameter. The highest and lowest single score is obtained when the transport distance increases and decreases by 50% (see Fig. 5). The relative change in the output is calculated as follows:

$$c_r = \frac{(v_0 - v_1)}{v_0} \times 100 \div \frac{(s_0 - s_1)}{s_0} \times 100$$

where: c_r = Relative change, v_0 = variable input at the baseline scenario, v_1 = variable input under the new scenario, s_0 = model score at the baseline scenario, and s_1 = model score under the new scenario.

The relative change in single score results is not significant when the energy consumption at the processor is considered. Despite differences of up to 50%, less than 1% of the change in the total output occurs. On the contrary, the modeled CSC is more sensitive to fluctuations in

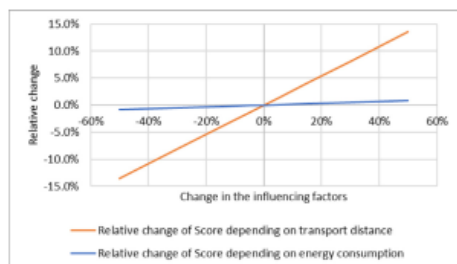

Fig. 5. Relative output changes depending on influencing factors.

Table 3
Economic indicator comparison.

Economic indicator	EEM 1	EEM 2
NPV	€ 520,786	€ 65,601
IRR	14.38%	9.92%
PI	1.95	1.25

the transport distance, with differences of up to 15% in the total output when this influencing factor increases or decreases by 50%.

These results show that the current CSC under evaluation is mainly sensitive to changes in the distance between the processor and the distribution center rather than the processor's energy consumption. Moreover, this analysis suggests the consistency of the model.

3.3. Life cycle cost

The results for the proposed LCC are summarized in Table 3, indicating the profitability of the *EEM-1* in a 25-year lifespan. The Return on the Investment (ROI) occurs in year ten under the assumed financial conditions. Although *EEM-2* shows economic feasibility, the Internal Rate of Return (IRR) is barely higher than the calculated weighted average cost of capital of 6.4%, the profit index (PI) is higher than 1.0, and the project also shows a positive Net Present Value (NPV).

Table 3 offers a comparison of results for all three economic indicators. Though both options show economic feasibility potential, the *EEM-1* would be the most attractive option for an investor from the NPV perspective. The IRR and PI also support the previous statement.

As a lower emissions alternative to natural gas and a means to minimize dependence on imported fossil fuels, technological pathways leading to biogas for energy generation should garner more significant interest in Latvia and other European nations in light of recent world developments. Rapid replacement of natural gas for heating purposes is essential for Latvia to attain energy independence and cut utility bills for its population. Results in Table 3 demonstrate the viability of such initiatives, which may become more attractive in light of Europe's present energy crisis.

4. Conclusions

Few studies have been undertaken to understand the environmental impact of food supply chains in Latvia, and even fewer for CSC in the fish sub-sector. There exists a gap in data that aids in identify-

ing potential hotspots in the supply chain that might help to take actions where they matter the most at the environmental and economic levels.

The present study evaluates the impact of cod fish's CSC in the Latvian context from an environmental (i.e., LCA) and economic (i.e., C-LCA) perspective reducing the identified gap. The impact of EEMs potentially enhancing the product's overall environmental performance was investigated. The results showed that thermal and electric energy production obtained from the anaerobic co-digestion of wastes (*EEM-1*) is the better of the two options evaluated. According to the results, the total environmental impact on Latvian fish supply chains could be reduced by applying customized EEMs. However, the infrastructure needed to achieve the intended results could be a downside of the EEM. For example, a larger CHP plant capacity may have more significant environmental effects while having lower marginal costs. Sensitivity analyses are essential to understand those factors in a CSC with the highest potential to affect a product's environmental performance negatively.

When comparing the two potential EEMs economically, the *EEM-1* shows more attractive results than the *EEM-2*. All economic indicators evaluated, NPV, IRR, and PI, show higher values for the *EEM-1*, considering in both cases their foreseeable lifespan. Nevertheless, future researchers should assess aspects such as the biogas upgrade and transport of other feedstocks from environmental and economic perspectives. Including other EEMs in evaluating CSC's economic and environmental performance is also recommended, depending on each case.

The results show how end-point categories score using LCA and the evaluation of economic indicators using a C-LCC assessment can be helpful for supply chain managers and single actors in the food supply chain. More research evaluating pertinent CSC and cutting-edge cooling technologies is required to grasp the potential advantages energy efficiency measures can achieve.

In the future, it is proposed to conduct cost-comparison research to evaluate the waste-to-energy potential of organic waste from the fish sector in light of the changing energy pricing scenario in Europe. It is necessary to aid decision-makers in examining hypotheses concerning the opportunity costs of constructing new energy plants utilizing low-cost fuels, such as industrial wastes.

The environmental burden caused by quality product losses is a topic to be investigated, along with a more in-depth study of fish product losses at the industrial, retail, and residential levels. This recommendation should be the guiding principle and advice for further research.

Ethical statement - studies in humans and animals

The authors declare that they have not performed any study or activity involving animals in this work.

Declaration of Competing Interest

The authors declare that they have no known competing financial interests or personal relationships that could have appeared to influence the work reported in this paper.

Data availability

Data will be made available on request.

Acknowledgment

This work has been supported by the European Social Fund within the project "Support for the implementation of doctoral studies at Riga Technical University."

Annex 1. Estimated results of solar electricity generation (EEM-2)

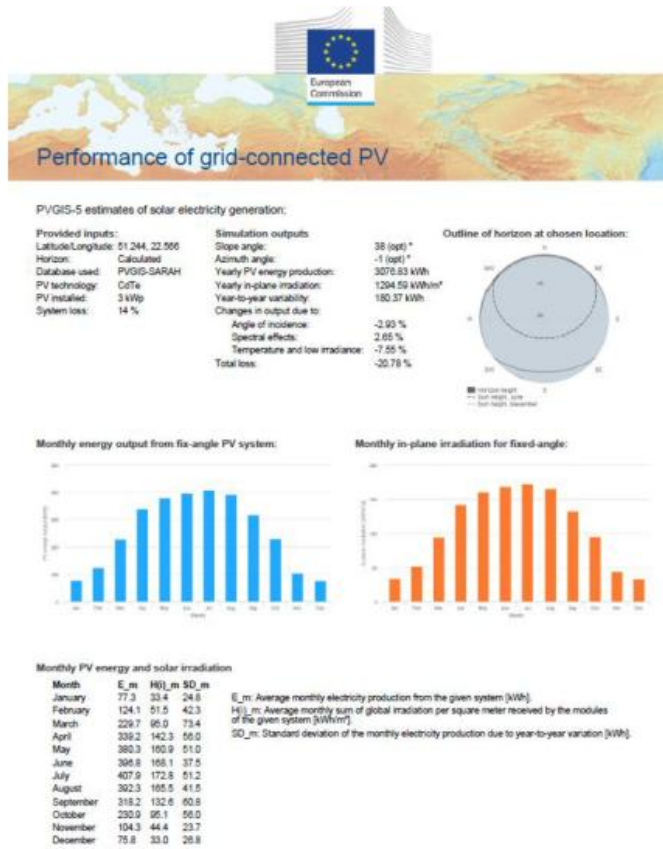

Annex 2. Mid-point category indicator results for the baseline scenario

Impact category	Unit	Processing	Transport to Dist. Center	Distribution Center	Transport to Retailer	Retailer
Carcinogens	kg C ₂ H ₂ Cl eq	4.8E-03	8.6E-04	1.4E-06	1.8E-04	1.8E-03
Non-carcinogens	kg C ₂ H ₂ Cl eq	3.2E-03	3.1E-03	1.7E-06	6.4E-04	2.3E-03
respiratory inorganics	kg pm2.5 eq	1.5E-04	1.4E-04	1.3E-07	2.9E-05	1.8E-04
ionizing radiation	kg c-14 eq	0.91	1.17	0.00	0.24	2.66
Ozone layer depletion	kg CFC-11 eq	9.9E-09	2.7E-08	2.4E-11	5.6E-09	3.3E-08
Respiratory organics	kg C ₂ H ₄ eq	1.1E-04	7.3E-05	4.2E-08	1.5E-05	5.7E-05
Aquatic ecotoxicity	kg TEG water	14.33	15.75	0.02	3.23	23.41
Terrestrial ecotoxicity	kg TEG soil	3.86	11.54	0.00	2.36	5.51
Terrestrial acid/nutri	kg SO ₂ eq	2.3E-03	3.1E-03	2.9E-06	6.4E-04	4.0E-03
Land occupation	m ² org.arable	1.6E-02	1.7E-02	3.5E-05	3.4E-03	4.8E-02
Aquatic acidification	kg SO ₂ eq	6.8E-04	5.8E-04	8.4E-07	1.2E-04	1.1E-03
Aquatic eutrophication	kg PO ₄ P-lim	2.1E-05	1.4E-05	1.2E-08	2.8E-06	1.7E-05
Global warming	kg CO ₂ eq	0.17	0.15	0.00	0.03	0.21
Non-renewable energy	MJ primary	3.90	2.38	0.00	0.49	3.60
Mineral extraction	MJ surplus	4.7E-03	1.6E-03	1.1E-06	3.3E-04	1.4E-03

References

- Baltic News Network (2020) Tariffs for Heating season in Latvia, BNN. Available at: <https://bnn-news.com/heating-season-in-latvia-starts-with-lower-tariffs-in-some-area-217480> (Accessed: 10 May 2021).
- Biukšane, I. and Jurdupa, I. (2016) Evaluation of the competitiveness of fisheries sector cluster, Research for Rural Development. Available at: <https://ortus.rtu.lv/science/iv/publications/30134/attachments/5424>
- Brown, T. (2014) Report on Quality and Energy Use of Proposed Technologies. Available at: <http://frisbee-project.eu/>.
- Cagno, E., Trianni, A., 2014. Evaluating the barriers to specific industrial energy efficiency measures: an exploratory study in small and medium-sized enterprises. *J. Clean. Prod.* 82, 70–83. doi:10.1016/j.jclepro.2014.06.057.
- Central Statistical Bureau of Latvia (2019) Rise in electricity produced in CHP plants from renewable energy sources. Available at: <https://stat.gov.lv/en/statistics-themes/business-sectors/energy/press-releases/2142-activities-chp-plants-2018>. (Accessed: 15 April 2021).
- Chan, Y., Kantamaneni, R., 2015. Study on Energy Efficiency and Energy Saving Potential in Industry and on Possible Policy Mechanisms. ICF Consulting Limited, pp. 1–461 December Available at: .
- Claussen, I.C., Indergård, E., Grinde, M., 2011. Comparative Life Cycle Assessment (LCA) of production and transport of chilled versus superchilled haddock (*Melanogrammus aeglefinus*) filets from Norway to France. *Procedia Food Sci.* 1 (2211), 1091–1098. doi:10.1016/j.profoo.2011.09.163.
- Coley, D., Winter, M., Howard, M., 2013. Section 4 food distribution and consumption. Sustainable Food Processing. John Wiley & Sons Incorporated.
- Diaz, F., et al., 2022. The ICEEE Toolbox. A holistic instrument supporting energy efficiency of cold food and beverage supply chains. *Environ. Clim. Technol.* 26 (1), 428–440.
- EC 2012/27/EU, 2012. Directive 2012/27/EU of the European parliament and of the council of 25 October 2012 on energy efficiency, amending Directives 2009/125/EC and 2010/30/EU and repealing directives 2004/8/EC and 2006/32/EC. *Off. J. Eur. Union* 1–56 October 2012.
- Statista (2021) Latvia Inflation rate. Available at: <https://www.statista.com/statistics/375251/inflation-rate-in-latvia/> (Accessed: 10 May 2021).
- Statista (2021). Electricity prices for households in Poland from 2010 to 2020. Available at: <https://www.statista.com/statistics/418110/electricity-prices-for-households-in-poland/> (Accessed: 4 May 2021).
- EU Commission (2021). Roadmap to a resource efficient Europe. Available at: <https://eur-lex.europa.eu/legal-content/EN/TXT/PDF/?uri=CELEX:52011DC0571&from=EN>
- European Commission, 2016. Facts and Figures on the Common Fisheries Policy - Basic Statistical Data - 2016 Edition. Office of the European Union.
- OECD (2021). Fisheries and aquaculture in Latvia. Available at: http://eurofish.dk/-/efweb/index.php?option=com_content&view=article&id=1239&Itemid=59 (Accessed: 8 February 2021).
- European Parliament, 2018. Directive 2018/2002/EU amending directive 2012/27/EU on energy efficiency. *Off. J. Eur. Union*.
- European Commission (2020). Photovoltaic Geographical Information System. Available at: https://ec.jrc.ec.europa.eu/pvg_tools/en/#PVP (Accessed: 26 April 2021).
- Eurostat (2021) Key figures on the European food chain 2021 edition.
- FAO, 2013. Food Waste Footprint - Impacts on natural resources. FAO, UN.
- FAO, 2016. The State of Food and Agriculture 2019. FAO Moving forward on food loss and waste reduction, the State of the World.
- Fieschi, M., Pretato, U., 2018a. Role of compostable tableware in food service and waste management. A Life Cycle Assessment study. *Waste Manag.* 73, 14–25. doi:10.1016/j.wasman.2017.11.036, (Oxford).
- Fieschi, M., Pretato, U., 2018b. Role of compostable tableware in food service and waste management. A Life Cycle Assessment study. *Waste Manag.* 73, 14–25. doi:10.1016/j.wasman.2017.11.036, (Oxford).
- Greggio, N., et al., 2018. Exploitable fish waste and stranded beach debris in the Emilia-Romagna Region (Italy). *Waste Manag.* 78, 566–575. doi:10.1016/j.wasman.2018.06.034, (Oxford).
- Han, J.W., et al., 2021. A comprehensive review of cold chain logistics for fresh agricultural products: current status, challenges, and future trends. *Trends Food Sci. Technol.* 109 (January), 536–551. doi:10.1016/j.tifs.2021.01.066.
- Hoang, H.M., et al., 2016. Life Cycle Assessment of salmon cold chains: comparison between chilling and superchilling technologies. *J. Clean. Prod.* doi:10.1016/j.jclepro.2016.03.049.
- Hognes, E.S., et al., 2011. Carbon footprint and energy use of Norwegian fisheries and seafood products. *Sustain. Marit. Transp. Exploit. Sea Resour.* 1031–1036. doi:10.1201/b11810-152.
- Goedkoop, M. et al. (2016). Introduction to LCA with SimaPro. Pre Consultants. Available at: <https://pre-sustainability.com/legacy/download/SimaPro8IntroductionToLCA.pdf>
- Ciroth, A., Huppes, G., Klopffer, W., Rudenauer, I., Rudenauer, L., Steen, B., Swarr, T., 2008. Environmental Life Cycle Costing. New York.
- International Renewable Energy Agency, 2020. Renewable Power Generation Costs in 2019. International Renewable Energy Agency Irena. Available at: .
- IRENA, 2018. International Renewable Energy Agency. Renewable Power Generation Costs in 2017. International Renewable Energy Agency Available at: .
- ISO, 2006. ISO 14044:2006, Environmental management - Life cycle assessment - Requirements and guidelines, International Organization for Standardization ISO 14044.
- Institute of Food Safety, Animal Health and Environment BIOR, Latvia, 2019. Latvia Annual Report for data collection in the fisheries and aquaculture sectors. Available at: https://datacollection.jrc.ec.europa.eu/documents/10213/1134334/Latvia_Annual_Report_2017_text.pdf/6429bb03-27a5-426f-ab18-0c6a384e99ac?version=1.0. (Accessed: 9 February 2021).
- Joliet, O., et al., 2003. IMPACT 2002+ a new Life Cycle impact assessment methodology. *Int. J. Life Cycle Assess.* doi:10.1007/BF02978505.
- Leandro, G.R., et al., 2021. Quality and safety of the Coalho cheese using a new edible coating based on the Ziziphus joazeiro fruit pulp. *Future Foods* 4, 100089. doi:10.1016/j.fufo.2021.100089.
- Mahmood, A., Iguchi, R., Kataoka, R., 2019. Multifunctional food waste fertilizer having the capability of Fusarium-growth inhibition and phosphate solubility: a new horizon of food waste recycling using microorganisms. *Waste Manag.* 94, 77–84. doi:10.1016/j.wasman.2019.05.046, (Oxford).
- Maiolo, S., et al., 2020. From feed to fork - Life Cycle Assessment on an Italian rainbow trout (*Oncorhynchus mykiss*) supply chain. *J. Clean. Prod.* doi:10.1016/j.jclepro.2020.125155.
- Di Maria, A., Eyckmans, J., Van Acker, K., 2018. Downcycling versus recycling of construction and demolition waste: combining LCA and LCC to support sustainable policy making. *Waste Manag.* 75, 3–21. doi:10.1016/j.wasman.2018.01.028, (Oxford).
- McDowall, W., et al., 2017. Circular Economy Policies in China and Europe. *J. Ind. Ecol.* 21 (3), 651–661. doi:10.1111/jiec.12597.
- Mena, C., Adenso-Diaz, B., Yurt, O., 2011. The causes of food waste in the supplier-retailer interface: evidences from the UK and Spain. *Resour. Conserv. Recycl.* 55 (6), 648–658. doi:10.1016/j.resconrec.2010.09.006.
- Musa, A., Gunasekaran, A., Yusuf, Y., 2014. Supply chain product visibility: methods, systems and impacts. *Expert Syst. Appl.* doi:10.1016/j.eswa.2013.07.020.
- Proskina, L., et al., 2018. Characteristics of the fishing industry in Latvia. In: Proceedings of the 19th International Scientific Conference 'Economic Science for Rural Development 2018', 49, pp. 56–64. doi:10.22616/esrd.2018.118 Bioeconomy, Finance and Taxes. Home Economics. New Dimensions in the Development of Society.
- Humbert, S. et al. (2002). IMPACT 2002 + : user Guide. Quantis. Available at: https://quantis.com/pdf/IMPACT2002_-_UserGuide_for_v02.21_30April2014a.pdf
- Ruiz-Salmón, I., et al., 2021. Life cycle assessment of fish and seafood processed products - a review of methodologies and new challenges. *Sci. Total Environ.* 761, 144094. doi:10.1016/j.scitotenv.2020.144094.
- Santonja, G.G., et al., 2019. Best Available Techniques (BAT) Reference Document On Food, Drink and Milk Industries. European Commission EUR 29978 EN.
- Sharifzadeh, M., Garcia, M.C., Shah, N., 2015. Supply chain network design and operation: systematic decision-making for centralized, distributed, and mobile biofuel production using mixed integer linear programming (MILP) under uncertainty. *Biomass Bioenergy* doi:10.1016/j.biombioe.2015.07.026.
- Rogelj, J. et al. (2018). Mitigation Pathways Compatible with 1.5°C in the Context of Sustainable Development. In: global Warming of 1.5°C. An IPCC Special Report on the impacts of global warming of 1.5°C above pre-industrial levels and related global greenhouse gas emission pathway. IPCC special report Global Warming of 1.5 °C, p. 82. Available at: https://www.ipcc.ch/site/assets/uploads/sites/2/2019/02/SR15_Chapter2_Low_Res.pdf.
- PRE Consultants (2008). Introduction to LCA with SimaPro 7. PRé Consultants, Netherlands, p. 1–88. Available at: <https://pre-sustainability.com/legacy/download/SimaPro8IntroductionToLCA.pdf>
- Stenmarck, A., et al., 2016. Estimates of European food Waste Levels. European Commission.
- Tassou, S.A., De-Lille, G., Lewis, J., 2012. Food Transport Refrigeration. Centre for Energy and Built Environment Research, Brunel University.
- Thollander, P., Palm, J., 2013a. Efficiency in Industrial Energy Systems. Springer London, Linköping doi:10.1007/978-1-4471-4162-4.
- Thollander, P., Palm, J., 2013b. Improving energy efficiency in Industrial SMEs. In: Improving Energy Efficiency in Industrial Energy Systems. Springer London, pp. 15–34. doi:10.1007/978-1-4471-4162-4_2.
- United Nations (2015) Paris Agreement. Available at: https://unfccc.int/sites/default/files/english_paris_agreement.pdf.
- United Nations - Economic and Social Council, 2019. Special edition: progress towards the Sustainable Development Goals. The Sustainable Development Goals Report 2019. Available at: <https://documents-dds-ny.un.org/doc/UNDOC/GEN/N19/134/95/PDF/N1913495.pdf?OpenElement>
- Vázquez-Rowe, I., Benetto, E., 2014. The use of a consequential perspective to upgrade the utility of Life Cycle Assessment for fishery managers and policy makers. *Mar. Policy* 48, 14–17. doi:10.1016/j.marpol.2014.02.018.
- Vivekanand, V., et al., 2018. Synergistic effects of anaerobic co-digestion of whey, manure and fish ensilage. *Bioresour. Technol.* 249, 35–41. doi:10.1016/j.biortech.2017.09.169, July 2017.
- Wernet, G., et al., 2016. The ecoinvent database version 3 (part I): overview and methodology. *Int. J. Life Cycle Assess.* 21 (9), 1218–1230. doi:10.1007/s11367-016-1087-8.
- Yasin, N.H.M., et al., 2013. Food waste and food processing waste for biohydrogen production: a review. *J. Environ. Manag.* 130, 375–385. doi:10.1016/j.jenvman.2013.09.009, June 2011.
- Zhang, R., et al., 2020. PET bottles recycling in China: an LCA coupled with LCC case study of blanket production made of waste PET bottles. *J. Environ. Manag.* 260, 110062. doi:10.1016/j.jenvman.2019.110062, August 2019.
- Zhao, H., et al., 2018a. An overview of current status of cold chain in China. *Int. J. Refrig.* 88, 483–495. doi:10.1016/j.jrefrig.2018.02.024.

- Zhao, H., et al., 2018b. An overview of current status of cold chain in China. *Int. J. Refrig.* 88, 483–495. doi:[10.1016/j.ijrefrig.2018.02.024](https://doi.org/10.1016/j.ijrefrig.2018.02.024).
- Ziegler, F., et al., 2016. Expanding the concept of sustainable seafood using Life Cycle Assessment. *Fish and Fisheries* doi:[10.1111/af.12159](https://doi.org/10.1111/af.12159).
- Wan, T. et al. (2011). Assessment of environmental benefits from phasing out CFCs in refrigerator industry of China, Beijing Daxue Xuebao/Acta Scientiarum Naturalium Universitatis Pekinensis. Available at: https://hero.epa.gov/hero/index.cfm/reference/details/reference_id/8631261

Article 4: The ICCEE Toolbox. A Holistic Instrument Supporting Energy Efficiency of Cold Food and Beverage Supply Chains.

The ICCEE Toolbox. A Holistic Instrument Supporting Energy Efficiency of Cold Food and Beverage Supply Chains

Fabian DIAZ^{1*}, Francesco ROMAGNOLI², Lisa NEUSEL³, Simon HIRZEL⁴,
Jasmin PAULUS⁵, Beatrice MARCHI⁶, Simone ZANONI⁷

^{1,2}*Institute of Energy Systems and Environment, Riga Technical University, Azenes iela 12/1,
Riga, LV-1048, Latvia*

^{3,4}*Fraunhofer Institute for Systems and Innovation Research ISI, Breslauer Str. 48, 76139 Karlsruhe,
Germany*

⁵*Adelphi Research Gemeinnützige GmbH, Alt-Moabit 91, 10559 Berlin, Germany*

⁶*Department of Mechanical and Industrial Engineering, University of Brescia, Via Branze, 38 25123,
Brescia, Italy*

⁷*Department of Civil, Environmental, Architectural Engineering and Mathematics, University of Brescia,
Via Branze, 43 25123, Brescia, Italy*

Abstract – Cold supply chains of food and beverage sectors represent one of the main drivers of the EU total final energy consumption. Within this context, food quality losses, changes in temperature regimes, energy use, environmental burdens, and the economic viability of energy efficiency measures are essential aspects to consider for improving cold supply chains' overall sustainability. This paper presents a dedicated toolbox, developed within the Horizon 2020 project ICCEE, for supporting decision-making and actors to assess energy efficiency path within a specific type of food cold-supply (i.e., meat, fish, milk and cheese products, fruits, and vegetables). More in specific the toolbox offers support for decision-makers to understand and minimize the specific energy consumption, to decrease the overall environmental impact even including non-energy benefit evaluation many times underestimated. The six separated tools merged within a unique toolbox consider different methodological approaches such as: assessment of the whole energy requirements in stock and flows considering the storage impact, the logistics and quality losses over time, implementation of Life Cycle Assessment and Life Cycle costs within the environmental and financial assessment of energy efficiency measures, based on a benchmarking approach. Finally, a specific approach implementing Multi Criteria Analysis was developed on selected key performance indicators such as specific and cumulated energy consumptions, quality losses and environmental burdens (i.e., global warming potential and water scarcity). The latest version of the ICCEE toolbox is available as free downloadable package on the ICCEE website.

Keywords – Cold supply chain; energy efficiency; LCA; multi criteria analysis; non-energy benefits

* Corresponding author.
E-mail address: fabian-andres.diaz-sanchez@rtu.lv

1. INTRODUCTION

Worldwide food production accounts for 80 % of deforestation worldwide, and it is responsible for 29 % of Greenhouse Gases (GHG) emissions and almost 70 % of freshwater use [1], [2]. The influence of Food Supply Chains (FSC) extends beyond environmental and economic issues, delivering impacts on social topics such as health and safety, wages, working hours, child work, gender equality, animal well-being, food safety, and traceability among others [2]–[4].

It has been estimated by the Food and Agriculture Organization (FAO), that 14–16 % of food in the world is lost in the supply chain before reaching the retail point [5]. If the full life cycle of food products is analysed, the third part of food produced is usually accepted as an actual value for Food Waste (FW), however, this number is merely a general estimation [5].

According to the FAO, FW can be defined as ‘the food that is appropriate for human consumption but it is discarded either before or after spoils, as a result from the negligence or a conscious decision to throw it away’ [6], [7]. In the specific case of the European Union (EU), it was appraised that in 2011, the amount of food produced was 865 kg/person, and the total amount of FW corresponded to 20 % for the same year [5], [7].

A supply chain can be conceptualized as the interaction among several organizations involved in the flow of products and services to their end customers [8]. The FSC comprises all units dedicated to manufacturing or harvesting products from the basic raw materials obtained from primary activities to deliver final food products to the consumer [9], [10]. The main activities of the agri-food supply chain involve raw material supply, manufacturing and postharvest, storage, distribution, and services [11]. Another definition for FSC is that the ‘*food supply chain is composed of raw material supply of agricultural products, farming, and breeding of agricultural products, processing of agricultural products, and the production, distribution, retail, and catering of food*’ [12], [13]. FSCs are unique, as they deal with the intrinsic issues of perishability, product deterioration, and organic wastes [14], [15].

The sectors contributing the most to the FW stream are the household with 53 %, followed by processing with 19 % [7]; the most significant plans, policies, and measures towards reducing FW in the EU, are addressed to as in the European Union Waste Framework Directive 2008/98. However, there is still the need to tackle FW in FSC, to ensure food quality, and decrease energy consumption estimated at 25 % of the EU-27 total final energy consumption [16]. Moreover, 30 % of potential savings in refrigeration and cooling activities has been estimated for the food sector [17].

The potential risks of hazards compromising the product's safety in the FSC could arise at any stage, undermining the whole supply chain [13]. Society, and various international organizations, like the FAO, the World Food Program (WFP), and the United Nations Environmental Program (UNEP), defined roadmaps to raise awareness among the public towards food safety looking to reduce food losses and reaching the ‘zero loss or waste food’ in the Zero Hunger Challenge [18], [19].

FW has become a key topic in developed societies due to the increasing environmental and social interest. Accordingly, food loss is the removal of any food and its inedible parts from the supply chain at any stage for whatever use, no matter if it is for recovery or disposal.

The causes for food losses, at least in Europe, are well known, despite not always being easy to track as they involve all actors in the FSC [20]. Among the more important causes, it is worth highlighting quality losses, reached expiration dates, damages during a particular stage, and food discarded due to a batch's sample not meeting the stipulated quality standard [21], [22]. Fortunately, some conditions for recovering FW to use in human consumption are

nowadays also known. However, the lack of data is an obstacle to estimating the amount and the quality conditions of food losses for most food typologies [23].

Nowadays, a large share of FSCs occurs in a low-temperature regime (i.e. chilled or frozen product) to extend the perishability time. Following the definition found in the Dictionary of Refrigeration [24], a Cold Supply Chain (CSC) could be defined as the representation of a 'series of actions and equipment applied to maintain a product within a specified low-temperature range from harvest/production to consumption'. A cold chain includes, but is not limited to, chilled and frozen foods and the subsequent refrigeration, the refrigeration of food after harvesting, transportation, storage, retail distribution, and home storage, aiming to maintain the quality, safety and to extend the shelf life for consumers [25]. The cold chain is vital for reducing FW and ensuring food safety, which influences the environment, water, and land resources [26], [27]. The equipment and facilities in the cold chain may include precooling and freezing facilities, cold storage warehouses, refrigerated trucks, freezers, display cabinets, and home refrigerators, which involve many new technologies and recent developments [12], [27]. Although food cold chain ensures food safety and prolong shelf life, frozen food's quantity is responsible for important energy and refrigerants consumption than a non-refrigerated FSC [28]. Thus, CSC must be adequately addressed to evaluate their real sustainability performance.

The environmental concerns caused by the activities related to CSCs can be divided into direct and indirect impacts. Direct impacts come from resources and emissions consumed and caused by activities within the supply chain's system boundaries. Resource extraction and use are linked to the use and transportation of raw materials, energy use, and other intermediate products necessary for carrying the actions within the involved processes.

The indirect impacts from food produced and not eaten (food losses) in carbon footprint terms are estimated at around 3.3 Gt CO₂ eq. This positions the FW issue as the source number three of carbon emissions after the USA and China if compared with direct country emissions [7], [12]. Hence, CSCs are vital to reduce food losses, yet they come with an environmental toll that must be assessed and addressed properly by improving the overall efficiency of their operations.

2. RATIONALE FOR EASY-TO-USE COLD SUPPLY CHAIN ASSESSMENT TOOLS

Recently, the concept of sustainability in the CSC has gained importance proposing a holistic view of the FSC system and its sustainability and aiming to optimize the benefits and results [29]. However, sustainability in the FSC and measuring its performance is difficult as not only the economic dimension must be considered should be the key assessment parameters. Despite the difficulties to be quantified, environmental and social issues must be brought into the assessment as the FSC involves multiple actors [30]. These actors and supply chain partners are required to work together to attain more sustainable outputs and increase the progress rate [31]. This can be achieved in the industrial sector, by reducing the energy consumption to cope with the challenges of meeting consumer expectations, national and international policies and regulations, and resource limitation [4]. Several studies highlight the lack of sustainability and energy efficiency assessment in the FSC under a holistic view [1], [32]. And although the topic has been addressed, it has been predominantly done from the FSC single actors' perspective, creating only a fragmented assessment [1].

One interesting and recent study attempted to evaluate the enablers for effective adoption of sustainability concepts in the FSC using different research methodologies for an Indian FSC case study [33]. Still, the quantitative evaluation of environmental impacts for sustainability assessments of FSC remains mainly unmapped.

FSCs and CSCs are inherently complex due to their numerous actors, stages and products. Understanding the energy and environmental performance of such chains becomes challenging and data intensive. This makes it particularly difficult for companies who seek to understand the relevance of particular chains, especially when they are small or medium-sized and only have limited resources and absorptive capacities. This calls for tools that can be readily applied to evaluate financial and environmental potentials for improvement within CSCs.

A major example has been developed in the FRISBEE project [34]. Its tool allows assessing the quality of food products, the energy consumption of different supply chains, and CO₂ emissions [34]. While the FRISBEE tool is quite robust for evaluating food quality changes across the CSC, it is limited to modelling steady in time scenarios. Furthermore, it does not allow for comparisons between the current state and future EEM implementations. Thus, a limitation in the environmental assessment appears, as generally, the global warming potential is the only category considered within existing tools, and it is not clear if a holistic approach has been used considering the whole life cycle of the food product evaluated.

A set of tools and methods is gathered and presented in [29], where topicality is aggregated. The main covered issues regarding agriculture supply chains presented are risk management, governance, cold chain management, globalization, information and communication technologies, logistics, short supply chains, and sustainability. However, each of these issues is approached individually by different methodologies.

The necessity for a tool that incorporates a holistic perspective arises to fulfil several objectives: to facilitate the understanding of energy-efficiency measures within CSC of the food and beverage sector, in particular for small and medium-sized companies, to take a holistic perspective on the entire CSC instead of looking at individual companies, only, and to facilitate decisions on investments in energy-efficient technologies.

3. CONCEPT AND IMPLEMENTATION OF THE ICCEE TOOLBOX

The suggested toolbox aims to introduce a set of analytical decision support tools. These shall allow easy-to-use but still customized analyses on the energy and sustainability performance of CSCs. As the food industry includes many different products, they are subjected to different production processes and logistic activities in terms of required operations and energy consumption. For this reason, simplifications are needed. These concern the representation of CSC which, as presented in Fig. 1, can be both regional and global. Breaking down the structure into individual stages is the main advantage and mission of the developed toolbox. It thus allows identifying the potential impacts in diverse stages and activities in the CSC. At the same time, the toolbox remains simple and practical while answering the needs of several stakeholders, ensuring accessibility and an easy-to-use interface.

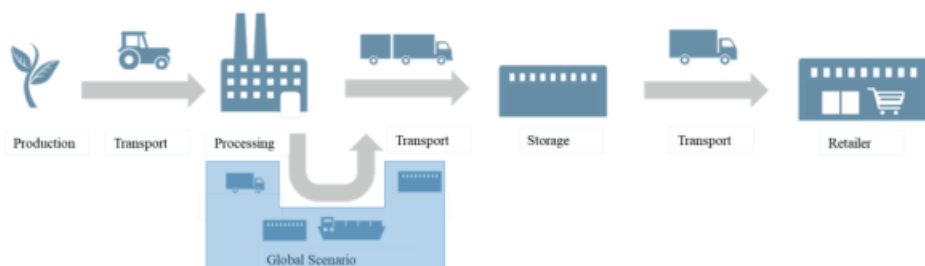

Fig. 1. The cold supply chain of food and beverage.

The toolbox consists of several tools covering different aspects related to the sustainability and energy efficiency of CSCs (Fig. 2). They encompass seven spreadsheets with a common-looking interface to increase the awareness among managers and actors within the CSC of energy efficiency measures from a holistic perspective instead of a conventional single actor perspective.

The whole toolbox is developed to allow the individual evaluation of cost-benefit and impact analysis on the implementation of Energy Efficiency Measures (EEM) in the CSC. As an added value, the toolbox can facilitate the identification of energy hotspots (i.e., processes, auxiliary services) within the whole CSC. The toolbox prioritizes the evaluation of energy savings and their benefits in different areas in independent and stand-alone versions to lessen data safety and incompatible software issues.

Ultimately, it can be said that this toolbox supports the assessment of energy flows, benchmarking, and life cycle impacts. The tools can be explored in detail on the project website [35].

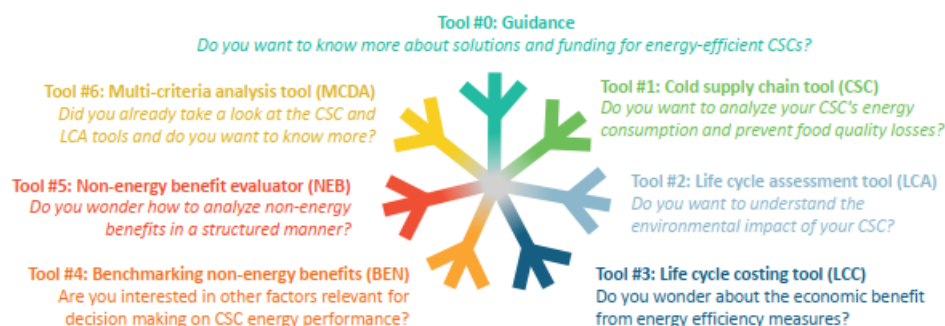

Fig. 2. Structure of the ICCEE toolbox.

Each of the tools can be used as a standalone one, to recognize a specific aspect on the CSC, or all the tools together, to obtain an overall final score that enables identifying a potential best scenario using multi-criteria analysis. A comprehensive description of each one of the toolbox components is presented in the following sub-sections.

3.1. Tool 0: Guidance

The guidance tool provides an introductory orientation on the toolbox itself, best practice examples, and funding opportunities. Next to a brief description of each tool includes the

collection of best practice examples (so-called factsheets) for energy efficiency measures tailored to the CSC. The EEMs relevant for CSCs have been grouped into ten categories: auxiliary technologies, buildings, employees, energy generation and recovery, industrial symbiosis, maintenance, management, monitoring and control, refrigeration system, and transport. Furthermore, the tool also provides an overview of national support schemes concerning energy efficiency in the CSC, including eligibility information and links to further information. Thus, the guidance tool serves as a repository of technical and funding information on energy efficiency within CSCs.

3.2. Tool 1: Cold Supply Chain Tool (CSC)

Chilled and frozen foods have a short shelf life and high sensitivity to the surrounding environment (i.e., temperature, humidity, and light intensity). For these reasons, they must be distributed within a specified time and require special equipment and facilities (e.g., refrigeration and dehumidification systems) from farm-to-fork to slow deterioration and to deliver safe and high-quality products to consumers. These requirements establish a trade-off between energy consumption and quality losses. The CSC tool deals with assessing the energy requirement in storage and transport activities along cold supply chains and the impact of storage time and temperature on food quality and energy consumption.

This model aims to support decision-makers in understanding and minimizing the overall specific energy consumption along cold supply chains, including quality losses. For this purpose, it allows to analyse:

1. Energy requirement in storage activities;
2. Energy requirements in transport activities;
3. Time-temperature effects on the food quality and consequent energy consumption.

The target group refers to supply chain managers and environmental managers of companies.

The supply chain proposed in the tool consists of up to seven stages from the raw material supplier to the retailer and includes a set of predefined products. In case the supply chain under analysis looks different, it is possible to omit or aggregate input of some stages to match the specific chain. The input required deals with the logistic activities of the stages with temperature control requirements. Specifically, three different macro-categories of input data can be distinguished:

- General inputs; in terms of annual demand rate of the final product, space occupation of the raw material and the final product, amount of raw material for producing a unit of the final product, and the product family of both raw material and final product;
- Storage data required for each warehouse in the chain; in terms of the average value of ambient temperature in the hottest season, inside reference temperature during the storage activities, annual consumption for refrigeration purpose for each energy carrier, storage size, production rate (if any), average warehouse utilization and average storage time at the warehouse;
- Transport data: in terms of fuel type, an average distance for a roundtrip, average travel time requiring refrigeration, distance travelled per unit of fuel, electrical power of refrigeration equipment (if any), a payload which defines the maximum amount of product transportable per trip, average amount of product transported, average value of ambient temperature in the hottest season, and inside reference temperature during the transport activities.

This tool provides some unique features like:

- Evaluation of the CSC's energy performance with a holistic and life cycle approach;

- Contribution analysis of each actor in terms of quality losses and energy consumption;
- Considerations of a trade-off between time-quality-energy for the overall cold chain, analysis of the influence of different temperature levels;
- Considerations of distribution, transportation and storage policies, and the assessment of the EEMs impacts and consequent prioritization.

3.3. Tool 2: Life Cycle Assessment Tool (LCA)

The LCA tool deals with the life cycle analysis of CSCs. This tool integrates inventory data from existing LCA databases to assess the environmental performance in three different areas of concern. The tool is designed to help practitioners or interested cold chain actors to quickly identify the environmental impact of cold supply chains in terms of Global Warming Potential (GWP), Cumulative Energy Demand (CED), and water scarcity based on the AWARE method (Available Water Remaining).

The model is based on the following data and methods: the determination of the GWP, based on the '2013 method' developed by the Intergovernmental Panel on Climate Change (IPCC) [30]. It delivers results for a timeframe of 100 years and expresses the impact in terms of kg of carbon dioxide equivalents. The determination of the CED is based on the method published by the environmental data system 'ecoinvent version 2.0' [36] and expanded for raw materials available in the life cycle database 'SimaPro 9' [37]. The AWARE method is used according to the recommendation of the international working group on water use assessment and foot printing (WULCA) [31]. It assesses the potential of water deprivation to either humans or ecosystems, based on the assumption that the less water remaining available per area, the more likely another user is deprived.

The main novelty of this tool relies on the quick assessment of environmental impacts while creating different scenarios for cold chains within most countries of the EU-27. Furthermore, the LCA methodology proposed by ISO 10040 and 14044 is simplified in this tool so the user can create their product system, by altering system boundaries to evaluate from a cradle-to-grave to a gate-to-gate system, including process taking place upstream and downstream from a single actor stage.

The LCA tool allows the user to select available raw material products from the tool database. Moreover, it also permits to consider if regional or global cold chains are to be modelled, automatically expanding the boundaries by inserting the proper stages necessary for evaluating a globalized supply chain. The unique tool features are:

- Evaluation of the environmental impacts (and benefits) of potential energy efficiency measures within CSCs, based on the LCA methodology following the ISO Standard 14044:2006;
- Exploration of the interdependency among technological and ecological systems;
- Streamlined, yet consistent, exploration of the overall environmental impact over possible cold chains of chilled and frozen products;
- Evaluation of all environmental contributions associated with transportation (with or without refrigerant – cooling system unit), the energy mix, and the waste management within each stage of the cold chain meeting the needs to have a holistic approach of all the main key actors in the whole chain of a product's life cycle;
- Possibility to include a feedstock product before entering in the cold chain (e.g., fresh fish) as a backstream process;
- Quantitative results in terms of the three environmental categories selected (i.e. Cumulated Energy Demand – CED, Global Warming Potential – GWP, Water footprint by AWARE approach).

In definitive, this tool allows stakeholders to quickly assess potential CSC's environmental impact without requiring deep knowledge in the LCA methodology.

3.4. Tool 3: Life Cycle Costing Tool (LCC)

The life cycle costs (LCC) methodology traces all relevant costs associated with a product for its entire life cycle. Three main types of LCC approaches are usually evaluated: conventional, environmental, and societal types [32].

A conventional LCC (C-LCC) is a pure economic evaluation and a quasi-dynamic method [32]. Generally, it includes (conventional) costs associated with a product that are borne directly by a given actor. This type of LCC is usually presented from the perspective of the producer or consumer alone. In this approach, external costs, that are not immediately tangible, are often neglected. Additionally, C-LCC does not always consider the complete life cycle; for example, end-of-life (EoL) operations are not included in any case. C-LCC is, to a large extent, the historic and current practice in many governments and firms.

The environmental LCC (E-LCC) uses the system boundaries and functional units equivalent to those of an LCA and is based on the same product system model, addressing the analysis to the complete life cycle. In this sense, the two analyses (i.e. LCA and E-LCC) are complementary in the fact that all costs are included as directly borne throughout the chain, including the already internalized cost of external effects. It assesses the cost that occurred during the Life Cycle in its LCA-related approach.

Societal LCC (S-LCC), as developed for cost-benefit analysis (CBA), uses an expanded macroeconomic system and includes a larger set of costs. These correspond to those that will be or could be, relevant in the long term for all stakeholders directly affected and for all indirectly affected through externalities (direct and indirect cost covered by society). In addition, S-LCC includes, but not necessarily, the monetized environmental effects of the investigated product as may be based on a complementary LCA.

This tool aims to deal with the life cycle costs of energy efficiency measures, allowing users to analyse these measures from a conventional economic perspective offering the possibility to review the impact from a social outlook. Furthermore, the tool offers unique features considering a holistic approach for CSCs in terms of an economic perspective, the evaluation of the economic feasibility of an energy efficiency measure for a specific actor of the CSC, the monetization of the environmental benefits of energy efficiency solutions for any actor included in the cold chain, as well as the evaluation of the LCC under the aforementioned different approaches.

3.5. Tool 4: Benchmarking On-Energy Benefits (BEN)

In addition to evident energy and CO₂ savings, EEMs can also entail non-energy benefits (NEBs). NEBs can be described as improvements due to energy-efficient technologies that yield 'additional enhancements to the production processes' [33]. Such enhancements include improvements in areas such as waste generation, emissions, operation and maintenance, production, and working environment. Prior investigations from the European context suggest that three out of four companies in the CSCs of the food sector see benefits besides lower energy bills when thinking about EEMs [38].

Against this background, this tool aims to help create awareness and understanding of the role of NEBs within companies of the CSC. For this purpose, it allows, firstly, to reflect on non-energy benefits in a structured manner and secondly, to compare this reflection with views by other companies active in CSCs. These views are based on survey results that were

explicitly collected to provide an overview of energy efficiency and non-energy benefits in cold supply chains.

Another key feature of the benchmarking is to compare the energy efficiency awareness of the individual company with that of the CSC to underline the particularities of CSCs. In addition, the users can compare their view with a peer group of similar company size. According to the survey, which serves as benchmarking basis, most companies at least sometimes consider energy efficiency in decision-making – both about their company and their cold supply chain. Concerning NEBs, the survey showed that most individual companies associate positive effects besides reducing energy demand and CO₂ emissions with EEMs. However, the general awareness of NEBs along the entire cold chain seemed to be lower in comparison.

To conclude, the benchmarking tool serves as an entry point to initiate a deeper reflection on the role of energy efficiency and non-energy benefits in the cold supply chain. Non-energy benefit evaluator (NEB).

It has been pointed out in the literature that NEBs can have a significant impact on the value of EEMs, even exceeding energy savings alone (e.g. [33], [39]). NEBs are easily underestimated, or even not considered, in the evaluation process of an energy-saving project [40], [41].

Building on the previously described benchmarking tool, the goal of the NEB evaluator tool is to introduce possible NEBs of EEMs, their classification, and their strategical assessment in the decision-making process of an EEM. For this purpose, first, NEBs can be chosen from a pre-defined list and can then be classified concerning their contribution to the strategy according to cost decrease, value proposition increase, and risk reduction for a selected EEM. In a second step, they can be prioritized and assessed qualitatively or quantitatively.

A key feature of the tool is to assess NEBs not only from an individual company perspective but also along the whole cold supply chain. Therefore, an exemplary EEM can be analysed and positive effects for the individual company and other stages of the chain can be considered.

To conclude, the NEB tool provides an advanced strategic assessment of non-energy benefits of specific energy efficiency measures to the particularities of cold supply chains.

4. THE MULTI-CRITERIA DECISION ANALYSIS TOOL (MCDA)

Previous tools allow assessing different key performance indicators (KPI) of the same cold chain which can lead to different results. The multi-criteria decision analysis (MCDA) tool allows us to understand the impact of adjusting temperature levels and storage levels on five of the main impact criteria used in life cycle analysis (assess in the CSC and the LCA tools). Moreover, it is possible to evaluate the potential of the energy efficiency measures while considering the optimization of different KPIs.

Multi-criteria analysis is a well-recognized method for solving complex issues and supporting the decision-making process, which allows selecting the most optimal choice determined primarily by a weighted set of criteria. The TOPSIS approach has been selected since it is recognized as a comprehensive method that gives a complete ranking of alternatives and avoids complex evaluation of each criterion in the selection process and the need for a large quantity of information in assessing these criteria [42], [43]. It is possible to select different weights for the impact categories and then carry out an automated multi-criteria assessment based on the TOPSIS algorithm. In TOPSIS, the shortest distance to the ideal solution and the furthest distance from the anti-ideal solution is considered evaluation of

alternatives. Similarly, as with other Multi-Criteria Analysis (MCA) methods, TOPSIS has a subjective parameter in form of assignment of weights to each selected criterion [40].

The main MCDA features can be described as being a macro-enabled expert tool to analyze the impact of parameter variation (what-if-analysis) of particular energy efficiency scenarios, the use of quantitative, and yet simple, ranking method for the evaluation of energy efficiency scenarios within the whole CSC, the identification of trade-off between various key performance criteria for the environmental impact in CSC, and a comprehensive approach merging technical, economic and environmental perspectives drawing on the supply chain analysis, the life cycle assessment and adding a multi-criteria approach.

5. VALIDATION AND LIMITATIONS

The ICCEE toolbox has been designed as an instrument for assessing the sustainability and energy performance of CSCs. Although initially conceived to help small and medium-sized enterprises, its potential is not limited to them. Large companies involved in CSC can also use the toolbox to evaluate potential EEMs at any stage, such as raw material suppliers or transport multinationals.

Using different individual tools, the CSC assessment provides a result (or score) for the different KPIs (i.e. specific energy losses, quality losses, GWP, CED, water scarcity) under evaluation. Then, such outputs are analysed in the MCDA tool (see Fig. 3), to obtain a definitive score considering the performance of the EEM under evaluation.

Results

The results for the base configuration as well as the best alternative from the TOPSIS analysis using the above input parameters and weights is shown below.

		Base	Best
Raw material temperature		293	270 K
Finished product temperature		285	277 K
Amount of final product in display area		500	500 kg
	Weights		
Specific energy consumption	20 %	0.02	0.02 kWh/kg
Quality losses	30 %	0.13	0.09 %
Global warming potential	15 %	5.30	4.95 kg CO ₂ eq/kg
Cumulated energy demand	15 %	0.2	0.2 MJ/kg
Water scarcity	20 %	0.85	0.84 m ³ eq/kg

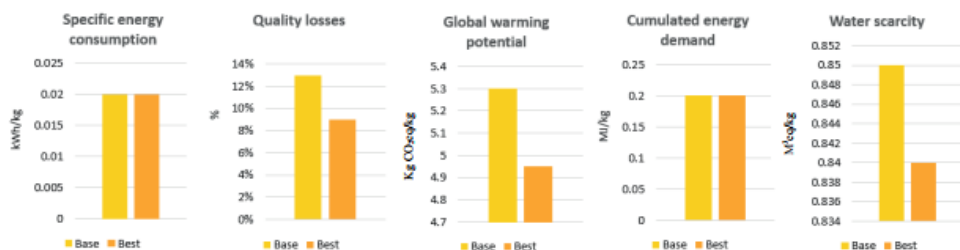

Fig. 3. MCDA output.

5.1. Toolbox Testing and Validation

The single tools merged in the toolbox are the result of an iterative development process. The validation process both consisted of a technical validation as well as a user-oriented test.

For the technical validation of the tool, data from companies relevant for the supply chain (e.g., raw material preparation, logistic and warehousing operations, production and processing of products, packaging) per sub-sector were collected to verify tool operation, in particular for the CSC, LCA and LCC tools. In terms of user tests, selected companies from the CSC were contacted to test early drafts. Through interviews, surveys, and meetings, data was collected from suppliers, retailers, and producers. In addition to that, secondary data from already existing databases were incorporated for validating the tools.

5.2. Impact of Results

The tool provides to actors involved in the cold chain important benefits for the evaluation of the consumption of each energy carrier for refrigeration purposes towards storage and transportation activities along the cold chain. The possibility to obtain an assessment of non-energy benefits and behavioural aspects along the whole CSC represents an innovation compared to outcomes from previous research studies. The 61 semi-structured interviews and the organized online survey with 122 participants of companies active in cold chains highlighted that energy efficiency is nowadays considered more for individual companies than for whole cold supply chains. The survey also identified specific aspects such as a variety of priorities among the actors, the lack of know-how and skilled personnel, lack of communication and information exchange along the cold chain which may hinder a more consistent implementation of energy efficiency measures.

The aim of establishing the toolbox was to provide easy-to-use tools to investigate the sustainability performance and energy efficiency of CSCs. For this, a compromise between the level of detail and still meaningful results is necessary. Thus, there are important limitations to the toolbox that needs to be mentioned. First, despite seeking to make the tools as simple as possible, the task of analysing entire CSCs still requires a considerable amount of input parameters, especially for the LCA, CSC, and LCC tools. Second, evidence from other investigations shows that CSCs can be very complex, and they can involve many actors within the same stages of the CSCs. Within the tools, a default setup of stages has been foreseen. For specific analysis of large chains, some real-life stages may need to be merged to fit into the categories of the tools. Third, default values for selected products are required for some of the tools. These may serve as proxies for other products, yet they cannot represent all details for a large variety of different individual cooled products. In sum, the tools are a simplification of reality as any model. During testing, there were several requests to include more options into the drop-down menus in tools where users can choose between different options. Yet, the general feedback from the tool tests was positive and several users expressed the wish to use the tool in the future which is a testament to its usefulness. Likewise, feedback on user-friendliness was generally positive and no inconsistencies within the models were reported. Yet some basic training might be necessary to avoid calculation errors or misusing the tool, especially in the case of the more complex tools.

6. CONCLUSIONS

The toolbox is a contribution to understanding the sustainability and energy efficiency performance of CSCs. It can be relevant for many different users, including students interested in environmental impact assessments or energy efficiency in industrial sectors, technical experts who seek to make estimations on sustainability, and companies operating in CSCs. Thanks to its simplified approach, the tools only need a limited amount of adaptation by any stakeholder who seeks to analyse a known CSC with a defined product system. Moreover, the holistic approach allows different actors to access information from other

stages in the supply chain, which would facilitate the evaluation of social issues for several stakeholders. The different options provided by the toolbox help to provide a holistic approach for the evaluation of CSCs, an aspect not always considered from interested parts or actors in the food cold supply sector. Moreover, the toolbox contributes to overcoming challenges such as the usual lack of deep knowledge in assessing methodologies or inconsistent choice of KPI and unsuitable tools that may hinder the efforts to choose a cost-effective measure (EEM) [44], [45].

The toolbox serves as an assessment tool to evaluate potential improvement scenarios for energy efficiency measures in the cold chain exploring technological, logistic and process-based aspects, evaluating the effect of quality losses and non-energy benefits. In addition, the tool provides also benchmarking properties facilitating ranking and sorting of the most sustainable and efficient solutions. Finally, the features presented in the tool can also aid in the future evaluation of the sustainability of CSCs, as environmental and economic dimensions are assessed.

ACKNOWLEDGEMENT

This work has received funding from the European Union's Horizon 2020 research and innovation program ICCEE project under grant agreement no. 84704. The paper's authors would like to thank all the ICCEE project partners for supporting the finalization of this work.

REFERENCES

- [1] Adams D., Donovan J., Topple C. Achieving Sustainability in Food Manufacturing Operations and their Supply Chains: Key Insights from a Systematic Literature Review. *Sustain. Prod. Consum.* 2021;28:1491–1499. <https://doi.org/10.1016/j.spc.2021.08.019>
- [2] United Nations. The sustainable development goals report 2019. New York: United Nations Publications, 2019.
- [3] Yigit S., Yigit A. M. Responsible Sourcing Practices In Turkey, The Case Of Food And Beverage Industry. *Proceedings of the OÜSOBIAD TEMMUZ 2016* 2016:463–477.
- [4] Xue L., et al. Missing Food, Missing Data? A Critical Review of Global Food Losses and Food Waste Data. *Environ. Sci. Technol.* 2017;51(12):6618–6633. <https://doi.org/10.1021/acs.est.7b00401>
- [5] Food and Agriculture Organization of the United Nations. The State of Food and Agriculture 2019. Moving forward on food loss and waste reduction. Rome: FAO, 2016.
- [6] Lipinski B., et al. Reducing food loss and waste. Working Paper, Installment 2 of Creating a Sustainable Food Future. Washington: WRI, 2016.
- [7] Stenmarck Å., et al. Estimates of European food waste levels. Stockholm: IVL Swedish Environmental Research Institute, 2016.
- [8] Mentzer J. T., et al. Defining Supply Chain Management. *J. Bus. Logist.* 2001;22(2):1–25. <https://doi.org/10.1002/j.2158-1592.2001.tb00001.x>
- [9] Manzini R., Accorsi R. The new conceptual framework for food supply chain assessment. *J. Food Eng.* 2013;115(2):251–263. <https://doi.org/10.1016/j.jfoodeng.2012.10.026>
- [10] Beske P., Land A., Seuring S. Sustainable supply chain management practices and dynamic capabilities in the food industry: A critical analysis of the literature. *Int. J. Prod. Econ.* 2014;152:131–143. <https://doi.org/10.1016/j.ijpe.2013.12.026>
- [11] Ahumada O., Villalobos J. R. Application of planning models in the agri-fod supply chain: A review. *Eur. J. Oper. Res.* 2009;196(1):1–20. <https://doi.org/10.1016/j.ejor.2008.02.014>
- [12] Zhao H., et al. An overview of current status of cold chain in China. *Int. J. Refrig.* 2018;88:483–495. <https://doi.org/10.1016/j.jrefrig.2018.02.024>
- [13] Liu G., et al. Improving Food safety in Supply Chain based on Big Data. *E3S Web Conf.* 2018;53:1–4. <https://doi.org/10.1051/e3sconf/20185303084>
- [14] Göbel C., et al. Cutting food waste through cooperation along the food supply chain. *Sustain.* 2015;7(2):1429–1445. <https://doi.org/10.3390/su7021429>
- [15] Chaturvedi A., Martínez-De-Albéniz V. Safety Stock, Excess Capacity or Diversification: Trade-Offs under Supply and Demand Uncertainty. *Prod. Oper. Manag.* 2016;25(1):77–95. <https://doi.org/10.1111/poms.12406>

- [16] Zanoni S., Zavanella L. Chilled or frozen? Decision strategies for sustainable food supply chains. *Int. J. Prod. Econ.* 2012;140(2):731–736. <https://doi.org/10.1016/j.ijpe.2011.04.028>
- [17] Monforti F., Dallemand J. F. Energy use in the EU food sector: State of play and opportunities for improvement Energy from Waste in Croatia View project. Luxembourg: Publications Office of the European Union, 2015.
- [18] Alamar M. del C., et al. Minimising food waste: a call for multidisciplinary research. *J. Sci. Food Agric.* 2018;98(1):8–11. <https://doi.org/10.1002/jsfa.8708>
- [19] Sgarbossa F., Russo I. A proactive model in sustainable food supply chain: Insight from a case study. *Int. J. Prod. Econ.* 2017;183(B):596–606. <https://doi.org/10.1016/j.ijpe.2016.07.022>
- [20] Devin B., Richards C. Food Waste, Power, and Corporate Social Responsibility in the Australian Food Supply Chain. *J. Bus. Ethics* 2018;150:199–210. <https://doi.org/10.1007/s10551-016-3181-z>
- [21] Verghese K., et al. Packaging's Role in Minimizing Food Loss and Waste Across the Supply Chain. *Packag. Technol. Sci.* 2015;28(7):603–620. <https://doi.org/10.1002/pts.2127>
- [22] Liljestrand K. Logistics solutions for reducing food waste. *Int. J. Phys. Distrib. Logist. Manag.* 2017;47(4):318–339. <https://doi.org/10.1108/JPDLM-03-2016-0085>
- [23] Willersinn C., et al. Quantity and quality of food losses along the Swiss potato supply chain: Stepwise investigation and the influence of quality standards on losses. *Waste Manag.* 2015;46:120–132. <https://doi.org/10.1016/j.wasman.2015.08.033>
- [24] International Dictionary of Refrigeration. Cold Chain Definition [Online]. [Accessed 27.09.2021]. Available: <https://dictionary.iifir.org/index.php?inputLang=en&truncPos=right&srchTerm=cold+chain&outputLang=xx&definLang=en&submit=View+results>
- [25] James C., Purnell G., James S. J. A Review of Novel and Innovative Food Freezing Technologies. *Food Bioprocess Technol.* 2015;8:1616–1634. <https://doi.org/10.1007/s11947-015-1542-8>
- [26] Mercier S., et al. Time–Temperature Management Along the Food Cold Chain: A Review of Recent Developments. *Compr. Rev. Food Sci. Food Saf.* 2017;16(4):647–667. <https://doi.org/10.1111/1541-4337.12269>
- [27] James S. J., James C. Advances in the cold chain to improve food safety, food quality and the food supply chain. *Deliv. Perform. Food Supply Chain.* 2010:366–386. <https://doi.org/10.1533/9781845697778.5.366>
- [28] Ramirez C. A., Patel M., Blok K. How much energy to process one pound of meat? A comparison of energy use and specific energy consumption in the meat industry of four European countries. *Energy* 2006;31(12):2047–2063. <https://doi.org/10.1016/j.energy.2005.08.007>
- [29] Lezoche M., et al. Agri-food 4.0 : a survey of the supply chains and technologies for the future agriculture To cite this version: HAL Id : hal-02395411 Future Agriculture. *Comput. Ind.* 2020;117:103187.
- [30] IPCC. Climate Change 2013: The Physical Science Basis. Contribution of Working Group I to the Fifth Assessment Report of the Intergovernmental Panel on Climate Change. Cambridge: IPCC, 2013.
- [31] Boulay A.-M., Benini L., Sala S. Marginal and non-marginal approaches in characterization: how context and scale affect the selection of an adequate characterization model. The AWARE model example. *Int. J. Life Cycle Assess.* 2020;25(12):2380–2392. <https://doi.org/10.1007/s11367-019-01680-0>
- [32] Ciroth A., et al. Environmental Life Cycle Costing. New York, 2008.
- [33] Worrell E., et al. Productivity benefits of industrial energy efficiency measures. *Energy* 2003;28(11):1081–1098. [https://doi.org/10.1016/S0360-5442\(03\)00091-4](https://doi.org/10.1016/S0360-5442(03)00091-4)
- [34] Alvarez G. Cold Chain refrigeration innovations the FRISBEE project. *J. Food Eng.* 2015;148:1 <https://doi.org/10.1016/J.JFOODENG.2014.11.010>
- [35] Wernet G., et al. The ecoinvent database version 3 (part I): overview and methodology. *Int. J. Life Cycle Assess.* 2016;21(9):1218–1230. <https://doi.org/10.1007/s11367-016-1087-8>
- [36] ICCEE. The ICCEE Toolbox, a Coverage from 7 Angles [Online]. [Accessed 27.09.2021]. Available: <https://iccee.eu/the-iccee-tool-2/>
- [37] Simapro manual PRé Consultants. Introduction to LCA with SimaPro 7. Amersfoort: PRé Sustainability, 2008.
- [38] Neusel L., et al. Energy efficiency from farm to fork ? On the relevance of non-energy benefits and behavioural aspects along the cold supply chain. *ECEEE Ind. summer study Proc.* 2020:101–110.
- [39] Thema J., et al. The multiple benefits of the 2030 EU energy efficiency potential. *Energies* 2019;12(14):2798. <https://doi.org/10.3390/en12142798>
- [40] Cooremans C. Competitiveness benefits of energy efficiency : a conceptual framework. *Proc. Eceee summer study* 2015:123–131.
- [41] Cooremans C. Make it strategic! Financial investment logic is not enough. *Energy Efficiency* 2011;4:473–492. <https://doi.org/10.1007/s12053-011-9125-7>
- [42] Pubule J., et al. Finding an optimal solution for biowaste management in the Baltic States. *J. Clean. Prod.* 2015;88:214–223. <https://doi.org/10.1016/J.JCLEPRO.2014.04.053>
- [43] Ishizaka A., Nemery P. Multi-criteria Decision Analysis: Methods and Software. New Jersey: Wiley, 2013.
- [44] Thollander P., Palm J. Efficiency in Industrial Energy Systems. Linköping: Springer London, 2013.
- [45] Zanoni et al. Improving Cold Chain Energy Efficiency: EU H2020 project for facilitating energy efficiency improvements in SMEs of the food and beverage cold chains. *Proceedings of the 6th IIR International Conference on Sustainability and the Cold Chain* 2020:292878. <https://doi.org/10.18462/iir.iccc.2020.292878>

**Article 5: Life Cycle Sustainability Evaluation of Potential Bioenergy
Development for Landfills in Colombia**

Life Cycle Sustainability Evaluation of Potential Bioenergy Development for Landfills in Colombia

Mabell RUIZ^{1*}, Fabian DIAZ²

¹National University of Colombia, Cra 45, Bogotá, Colombia

²Institute of Energy Systems and Environment, Riga Technical University, Azenes iela 12/1, Riga, LV-1048, Latvia

Abstract – The Colombian energy matrix faces significant changes toward meeting its energy needs while fulfilling its pledges in the Intended National Determined Contributions linked to the Paris Agreement. The country has developed a plan for energy transition with a 2050 horizon, a strategy reflected and supported by new legislative packages. Within its design, biomass and biomass waste play a vital role in bioenergy production; however, the benefits of deploying new bioenergy production facilities have not been fully accounted for, including only an economic and climate change perspective. In this work, a Life Cycle Sustainability Assessment of a potential bioenergy plant for industrial symbiosis with the largest landfill in the country is undertaken, avoiding environmental burden shifting between environmental damage categories and exposing the social potential of such projects. The results show how these types of projects are economically feasible and have the potential to boost the sustainable development of local communities, which under the Colombian context, have been structurally relegated from conventional economic growth for decades.

Keywords – Bioenergy; landfill; life cycle assessment; sustainability

Nomenclature

GHG	Greenhouse gases
NCRES	Non-Conventional Renewable Sources
PERS	Sustainable Rural Energization Plans
CDM	Clean Development Mechanisms
LCT	Life Cycle Thinking
LCA	Life Cycle Assessment
AD	Anaerobic Digestion
CRSNM	Consorcio Relleno Sanitario Nuevo Mondonedo
LCC	Life Cycle Cost
S-LCA	Social Life Cycle Assessment
AHP	Analytical Hierarchy Process
	Technique of Order Preference Similarity to the Ideal
TOPSIS	Solution
End-of-Life	End-of-Life stage
ISO	International Standard Organization

* Corresponding author.
E-mail address: maaruizre@unal.edu.co

FU	Functional Unit
FW	Food Waste
CHP	Cogeneration of Heat and Power
LCI	Life Cycle Inventory
DOC	Degradable Organic Content
LHV	Low Heating Value
C-LCC	Conventional Life Cycle Cost
OPEX	Operational Costs
O&M	Operation and Maintenance
CAPEX	Capital Costs
UN	United Nations
SDG	Sustainable Development Goals
SETAC	Society of Environmental Toxicology and Chemistry
NPV	Net Present Value
IRR	Internal Rate of Return
PI	Profit Index

1. INTRODUCTION

Aligned to the global agenda, Colombia recognizes the importance of its wealth in terms of biodiversity and, at the same time, identifies the need to work on reducing the country's vulnerability to the social, environmental, and economic challenges it currently faces. As part of its strategy to mitigate the consequences of climate change, Colombia has taken actions such as: adhering to the initiative of compliance with the Sustainable Development Goals [1]. Signing the commitment to reduce 51 % of its greenhouse gases (GHG) emissions [2], [3] and promoting the incorporation non-conventional renewable energy sources (NCRES) through Law 1715 of 2014 [4].

To comply with these commitments, a new development model and transition plan were established with a horizon of 2050. This plan recognizes the energy potential of the country. It identifies the main risks that the territories face, which is why it has established three main objectives:

1. Migrate towards a more competitive, efficient, and resilient energy system through the widespread use of NCRES and the adoption of new technologies;
2. Eliminate energy gaps, introducing new business models and new technologies to accelerate the universalization of electricity and fuel gas service throughout the territory;
3. Lead the fight against climate change, prioritizing sustainable mobility with the massive introduction of zero and low emission fuels, the use of hybrid and electric vehicles, and energy efficiency policies at the residential, commercial, and industrial levels [5].

This plan defines a route and specific targets for the generation of wind and solar energy, describes those related to hydrogen, and in a transversal way, and includes the importance of expanding and encouraging the use of biomass as an unconventional energy source [5]. Although the number of bioenergy projects in the country is not fully recorded, different

initiatives show this energy's growth and potential. From the private sector, the Bioenergy Cluster of Valle del Cauca, which is made up of 2891 companies, of which 2839 are biomass producers, underlines among many due to its economic potential [6].

Two initiatives stand out from the public sector, the Sustainable Rural Energization Plans (PERS) and the Clean Development Mechanisms (CDM). The PERS strength is to include residual biomass as an alternative energy resource [7]. The CDM program identifies the development and implementation of large-scale systems for the energetic use of waste projects approved by the Ministry of Environment and Sustainable Development, aiming to reduce carbon dioxide emissions [8].

In this context, the present work seeks to quantify the environmental, economic, and social impacts of an energy generation project from landfilled biowastes in Colombia using Life Cycle Thinking (LCT) tools. This specific methodology has already been used for similar projects in the geographical context, such as the case of the environmental Life Cycle Assessment (LCA) for biogas production from wastewaters in Colombia [9] or the sustainability evaluation of different paths for wastewater treatments in Brazil [10]. In [11], the methane biochemical potential from organic wastes in Colombia landfills is explored in a municipal solid waste management process. In another work, the potential biogas generation from landfilled organic wastes in Colombia was forecasted and estimated at 2640.4 TJ/year [12] while describing its potential and different uses. For biogas production, the most employed technique is anaerobic digestion (AD), thanks to low operational costs and its positive energy balance [13].

1.1. Bioenergy Production in Colombia

Different definitions are found for the term Bioenergy. Still, overall, it can be defined as the conversion of biomass from agricultural and forestry waste, organic municipal waste, and energy crops into useful energy carriers such as heat, electricity, and power [14]. Bearing in mind Colombian regulations, Bioenergy must be understood as the energy obtained from those NCRES based on any organic matter's spontaneous or induced degradation. The organic matter must surge from a biological process and the metabolic processes of heterotrophic organisms to fit this definition. It must not contain or have been in contact with any trace of elements that confer some degree of danger [4].

Even though Colombia's electricity energy matrix is mainly based on hydropower as a primary energy, it has come up with initiatives and regulations that encourage the incorporation of other renewable energies [15] and the energy transition towards carbon neutrality [16].

Although solar and wind energy production is predominant in these initiatives, progress has been made in identifying the country's bioenergy potential [17] and implementing projects to determine the technical and economic feasibility of using biomass in energy generation [18].

The mentioned incentives and the high potential of Bioenergy available in the country have opened a new market for energy projects exploiting residual biomass. Bioenergy production has grown at a rate of 19 % per year, reaching 296 MW installed in 2017, of which 291 MW corresponds to the utilization of solid biomass and 4 MW to the use of biogas [19]. In this context, there is a growing interest in evaluating the environmental impacts and identifying the social contributions of such projects. However, a holistic evaluation including all the relevant criteria that establish bioenergy production sustainability in Colombia is still lacking.

In Colombia, Bioenergy has been focused mainly on using solid biomass for thermal energy production. Fig. 1 shows how the potential for biogas production has only begun to develop in recent years.

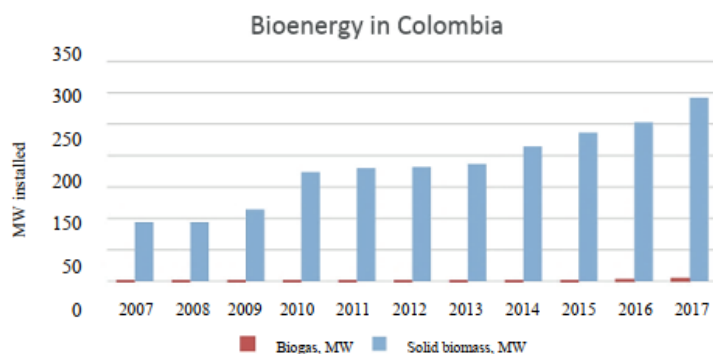

Fig. 1. Bioenergy growth in Colombia [19].

By recognizing the country's potential for bioenergy and biogas generation from organic wastes estimated at 342 570 TJ [20], understanding the guidelines defined by the regulators, and having as a precedent the low implementation of biogas production alternatives, this paper analyses the life cycle of biogas generation in the landfill of Mondonedo, the largest one in Colombia.

1.2. Mondonedo Landfill

The landfill Nuevo Mondonedo is in the Province of Bojacá-Cundinamarca, Colombia, 40 km west of Bogota, and it is operated by Consorcio Relleno Sanitario Nuevo Mondonedo (CRSNM). The landfill started operations in 2007 as a response to the need to increase the landfill capacity from the Dona Juana landfill [21], [22], and has an estimated lifetime of 32 years. In 2020 Nuevo Mondonedo Landfill served 91 users distributed in 78 municipalities and 20 private clients and received approximately 1.595 tons of domestic, industrial, and commercial waste per day in 6.5 ha [23]. The waste characterization composition is as follows: Paper and cardboard: 8.3 %, organic matter: 52 %, textiles: 10.2 %, garden park, wood: 59 %, and other residues: 8 %. An expansion to approximately 17 ha during the project's lifetime has been projected for an overall capacity of 7 102 190 m³ of residues [24].



Fig. 2. Nuevo Mondonedo landfill location.

Since 2017, CRSNM has obtained approval to develop a project under the CDM scheme to capture and use landfill gas from the Landfill Nuevo Mondonedo. The project's development includes the capture of methane to produce electricity for on-site consumption and the national grid. Heat will also evaporate leachates, and a backup enclosed flaring unit is also considered [24].

Currently, GHG reductions are estimated from the combustion of landfill biogas burned in a flare, power generation equipment, and leachate evaporation. The project aims to diminish methane through burning and combustion in engines and microturbines. A total GHG reduction capacity of 54 254 tCO₂eq, 89 % corresponding to the burning of methane, and 11 % from the energy generation (16) was calculated. Additionally, it is believed that better management of landfill gases would improve the quality of life of surrounding communities and generate new jobs. However, these socio-economic impacts are still not quantified.

The current operation that includes methane collection, a burning system, and a future power generation system in the Mondonedo landfill would positively impact climate change. However, fully environmental or social performance has not been evaluated, nor has the potential for a complete energy recovery system through biochemical and thermochemical processes. For this reason, a model for implementing an AD plant for biogas production, methane upgrading, and energy recovery in this landfill is undertaken in this work. The results cover the three sustainability dimensions using Life Cycle Assessment (LCA), Life Cycle Cost (LCC) evaluation, and Social Life Cycle Assessment indicators (S-LCA).

2. METHODOLOGY

Sustainability evaluations of different products have been undertaken from multiple perspectives in the last two decades. One can take, for example, the sustainability evaluations conducted by corporations mainly to obtain green certificates or for the release of their sustainability reports. However, these reports only focus on the abatement measures of few environmental impacts or consider CO₂ emissions alone as a proxy for environmental performance. In contrast, others issue reports about their corporate social responsibility [25], including some social aspects. The authors of [10] used the "dashboard of sustainability" method to rank different technological paths for wastewater treatment by combining qualitative and quantitative scores. On the other hand, for biofuels ranking and decision-making analysis, it is recommended to use fuzzy multicriteria decision methods such as AHP and TOPSIS [26].

Nonetheless, it is not within the scope of this work to compare different projects' sustainability performances, mainly due to missing data from similar landfills in the country. Without trade-offs or burden-shifting between sustainability dimensions, this work focuses on calculating the potential score of the proposed energy production path in the three sustainability dimensions/pillars [27].

2.1. LCA

LCT is the decision-making process where the entire life cycle of a product is considered [28]. This concept applies to manufactured products, which have an initial life stage with the harvesting and resources extraction, production, distribution, use, and management of waste, also known as the end-of-life (EoL) stage. Therefore, the LCA is an LCT tool that evaluates the implications of the entire life cycle of a product in the environment [29].

Results from LCA provide information that reflects the environmental performance of a specific product in different areas of concern or impact categories [30], [31]. The critical advantage of LCA, when compared to other stand-alone environmental impact evaluation methodologies, is that it avoids “burden-shifting” [32] by allowing the assessment in several impact categories (depending on the specific method selected) [33]. The whole framework and the requirements and guidelines for developing an LCA are given by the ISO standards 14040 and 14044 [34].

2.1.1. Goal and Scope

This LCA study aims to evaluate the environmental impacts of the potential commissioning of an energy recovery plant for the Mondonedo landfill facilities. The scope of this evaluation starts by defining the functional unit (FU), 36 500 t/year of food waste (FW) processed, understood as 100 t/day for landfill sites' managerial purposes. The scope of this study does not include the activities related to the sorting and recovery of organic material. It corresponds to a gate-to-gate approach comprehending the AD, biogas production, purification and upgrading to biomethane, and thermal and electrical generation by cogeneration of heat and power (CHP). The system boundaries of the study can be seen in Fig. 3. An attributional system model is used for this study.

2.1.2. Life Cycle Inventory

The Life Cycle Inventory (LCI) includes material and energy flows and the equipment and infrastructure required for the whole energy production process. The primary data regarding total waste, food waste composition in the waste, and Degradable Organic Content (DOC), has been retrieved from the report for reductions of emission project of Mondonedo landfill considering average values for the period 2007–2016 [24]. For the biogas conversion, biogas upgrade to biomethane, and CHP plants operation, a process model was built in *SuperPro Designer*® to conduct mass and energy balances of all elementary flows. All data presented in this section is normalized to the FU.

The AD stage includes the transport of the sorted FW by municipal waste collection vehicles to the treatment plant, which is assumed to be located just beside the Mondonedo landfill with an estimated distance of 30 km (round trip), similarly to the one reported for the Colombian geography at [9]. The AD plant consists of 5 sets of 2 biodigesters in series – with the sets in parallel – each with a working volume of 7000 m³.

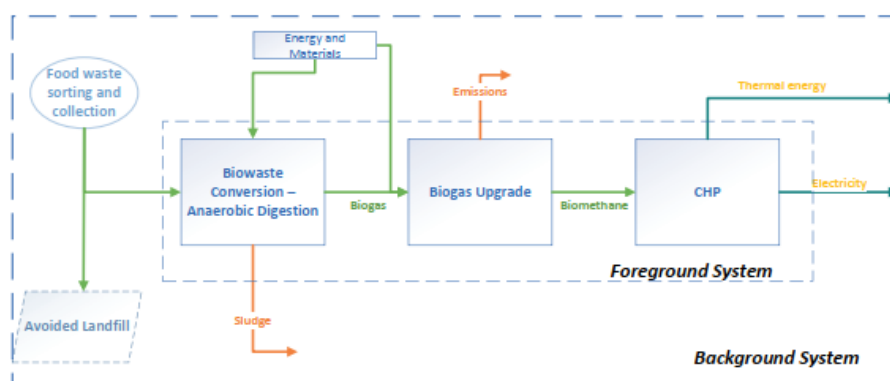

Fig. 3. System Boundaries for the proposed case scenario.

For the LCA model, the construction of the AD plant is taken from the *Ecoinvent 3.7* database. The unit process refers to a plant with an installed capacity of 10 000 t/year; thus, the value is normalized considering the FW input. Water consumption of one ton per 100 t of FW is assumed for makeup and blending before injecting the flow into the biodigesters. The authors calculate electricity and heat demands in line with reported values in [35] for electricity consumption of 101 kWh/t_{FW} and 338 MJ/t_{FW}. The AD plant analysed relies on a continuous mesophilic operation at 35–39 °C with a calculated biogas conversion of 139.9 Nm³/t_{FW}, which is in line with values reported in [36]–[38]. A biogas molar composition of 60 % CH₄ was found for a 62 vol % of CH₄ and 32 vol % CO₂ ratio, in line with values reported in [39]. The resulting sludge or digested is assumed to be treated accordingly with the available ‘*Digester Sludge | market for*’ unit process in the *Ecoinvent* database. Biogas and methane mass balances were performed following the reported concentration for medium-rich biogas [40].

The biogas obtained from AD is then upgraded to biomethane by the use of water scrubbing technology, one of the most used techniques when it comes to large systems (>100 m³/h) [41]–[43]. The principle relies on the biogas’ CO₂ and H₂S higher solubility in water than methane’s, something described by Henry’s law (see Eq. (1)), which explains the relation between the concentration of a gas in a liquid in contact with such gas, and the partial pressure of the gas [44].

$$C_A = K_H \cdot p_A, \quad (1)$$

where

- C_A Molar concentration of an A gas in the liquid;
- K_H Henry’s constant;
- p_A Gas’s partial pressure.

Within a high-pressure absorption column (high pressure boosts the dissolubility of gases in water [45]), carbon dioxide is removed from the raw biogas, dissolved into the water, and sprayed from the top of the scrubber in counter-current to the biogas. Some carbon dioxide with methane traces is released from the water in the flash column and recirculated into the main biogas stream. The amount of water necessary to sequester a certain amount of carbon dioxide, as represented in Eq. (2), depends on desired CO₂ concentration in the upgraded gas, the solubility of the carbon dioxide in the water, which is influenced by temperature and pressure in the scrubber, and by the column design [43], [44].

$$Q_w \text{ (L/h)} = \frac{Q_{\text{CO}_2} \text{ (g)} \text{ (mol/h)}}{C_{\text{CO}_2} \text{ (aq)} \text{ (M)}}, \quad (2)$$

where

- Q_w Water flow needed in the column;
- Q_{CO_2} Molar flow to be removed from the biogas;
- C_{CO_2} Calculated carbon dioxide solubility (represented as the maximum concentration in the water) using Eq. (1).

In this study, 85 % of recirculation water into the absorption column is assumed after regenerative absorption by air injection is performed at the desorption column [45].

The resulting upgraded gas effluent consists of a methane concentration of 98 % on the final stream [35], [38], considering 4 % losses during the upgrading process [43] and 2 % of remaining carbon dioxide in the stream right after the absorption column.

The CHP plant construction unit process is also taken from the *Ecoinvent* database (Construction work, heat and power cogeneration unit, 160 kW electrical) and normalized to a total capacity of 2 MW and 25 years. The CHP modelled process includes utilities and materials such as lubricating oil, cooling water, and the cooling tower. Also, emissions to air, such as carbon dioxide (biogenic), carbon monoxide, particulates less than 2.5 μm , and other combustion emissions were considered, and the treatment of the waste mineral oil.

An electrical efficiency of 38 % and 46 % for thermal energy, a methane's low heating value (LHV) of 10 kWh/m³ and a capacity factor of 8030 h/year have been assumed considering values reported in [9], [37]. The modelled installed capacity (2 MW) fits the requirements to produce the calculated electricity and heat outputs of 10 318 and 12 490 MWh/year, respectively (before losses and meeting internal demands). A summarized inventory is displayed in Table 1 for a plant capacity of 36 500 t_{FW}/year and 25 years of lifespan.

TABLE 1. SUMMARIZED LCI

Material	Amount	Unit
Anaerobic Digestion		
Food waste	36 500	t
Anaerobic digestion plant (construction)	0.146	p
Municipal waste collection service by 21 metric ton lorry	5.48E05	tkm
Water	365	t
DOC in FW	15 %	
Electricity (internally supplied from CHP)	1.47E+06	kWh
Heat (internally supplied from CHP)	12 337	MJ
Sludge from Anaerobic Digestion (emission)	30 438	t
Biogas (output)	609.9	kmol/day
Biogas density [40]	1.187	g/L
Upgrade		
Air compressor	0.2	p
Absorption column	0.05	p
Softened water	122.8	t
Electricity (internally supplied from CHP)	1.53E+06	kWh
Methane stream (output)	365.9	kmol/day
Carbon dioxide (biogenic)	3.86E03	t
Wastewater treatment	122.8	t
CHP		
Construction work, heat and power cogeneration unit, 160 kW	0.625	p
Lubricating oil	2663.7	kg
Carbon dioxide, biogenic (emissions)	4 972 150.7	kg
Carbon monoxide, biogenic (emissions)	14 206.1	kg
Particulates, < 2.5 μm (emissions)	13.3	kg
Sulphur dioxide (emissions)	48.8	kg
Other emissions (dinitrogen monoxide, methane, nitrogen oxides, NMVOC, etc.)		
Waste mineral oil (waste treatment)	2663.7	kg

From the total energy produced at the CHP plant, electricity and thermal energy are used to meet the internal demand for AD processes and upgrading. An estimated value of 41 kWh_e/t_{FW} and 338 MJ_{th}/t_{FW} are required for anaerobic digestion [35], [38], and 0.3 kWh_e/m³ biogas for

the upgrading process [36]. Additionally, 5 % of electricity losses and 10 % of thermal energy losses are considered during the cogeneration of heat and power due to transmission and pipelines, respectively.

2.2. LCC – Life Cycle Cost Evaluation

LCC methodology is commonly used to scan for the best alternative among products and services from an economic perspective [46]. The LCC is beneficial when a similar approach to the one used in the LCA is undertaken. It allows for adopting the best solution in the long-term by looking beyond solely the purchase price.

In this study, a Conventional Life Cycle Cost (C-LCC) is conducted following the exact system boundaries of the LCA model, a gate-to-gate approach. Nevertheless, for this economic evaluation, a full-scale plant considering the annual average food waste landfilled value in Mondonedo is modelled to include the effects economy of scales, which maximizes the cost efficiency by increasing production [47].

2.3. Social LCA

The social dimension is one of the pillars of sustainability. A sustainable society should reach this state only after all its actors have met the basic needs and enjoy sustainable development benefits [48]. The importance of the social dimension is something the United Nations (UN) reflects in the current policy for Sustainable Development Goals (SDG) [49], among other regional and international initiatives such as the Guidance on Social Responsibility (ISO 26000).

S-LCA methodology was born as an expansion of the LCA method, and it is now understood and classified as an LCT tool [28]. The indicators from the S-LCA evaluated in this study are assessed using qualitative evaluations of some of the social impact indicators required by the UN and reported in [50]. The stakeholders and impact categories selection has been made following the latest guidelines proposed by the Society of Environmental Toxicology and Chemistry (SETAC) and the UN [51]. The main stakeholders considered are the local community, consumers, workers, and society. The indicators evaluated were chosen based on the available information and interviews performed with landfill workers: local employment, community engagement, safe and healthy living conditions, fair salary, health and safety, social benefits, public commitment to sustainability issues, and contribution to economic development [52].

3. RESULTS AND DISCUSSION

The environmental impact assessment from the proposed FW valorization scenario was evaluated using *SimaPro 9.2* [54], and the LCI data was taken from the *Ecoinvent database v.3.7* [55]. The chosen method for calculating the potential environmental impacts is *IMPACT 2002+* [33], [55], available in the *SimaPro* libraries. This method allows the practitioner to evaluate early stages in the cause-effect chain while also delivering results in damage-oriented categories, preferred when communication to the public is desired [56]. The results at the mid-point category level for the proposed scenario are displayed in Table 2.

TABLE 2. CHARACTERIZATION RESULTS (MID-POINT CATEGORIES)

Impact category	Unit	Total	Anaerobic Digestion	Biogas Upgrading	CHP Unit
Carcinogens	kgC ₂ H ₃ Cl _{eq}	-6.4E+04	6.0E+04	4.3E+02	-1.2E+05
Non-carcinogens	kgC ₂ H ₃ Cl _{eq}	2.5E+05	2.6E+05	1.1E+03	-1.6E+04
Respiratory inorganics	kgPM _{2.5eq}	3.5E+03	3.3E+03	8.2E+00	1.9E+02
Ionizing radiation	BqC-14 _{eq}	8.2E+06	8.8E+06	4.2E+04	-6.0E+05
Ozone layer depletion	kgCFC-11 _{eq}	1.6E-01	2.5E-01	3.2E-04	-8.2E-02
Respiratory organics	kgC ₂ H _{4eq}	1.9E+03	1.7E+03	2.5E+00	2.4E+02
Aquatic ecotoxicity	kg TEG water	1.7E+08	2.5E+08	1.9E+06	-8.4E+07
Terrestrial ecotoxicity	kg TEG soil	3.8E+07	4.8E+07	5.6E+05	-1.0E+07
Terrestrial acid/nutri	kgSO _{2eq}	1.1E+05	9.0E+04	1.2E+02	2.1E+04
Land occupation	m ² org.arable	5.9E+04	6.6E+04	9.1E+02	-8.0E+03
Aquatic acidification	kgSO _{2eq}	1.5E+04	1.5E+04	3.2E+01	2.3E+00
Aquatic eutrophication	kgPO ₄ P-lim	1.1E+03	1.2E+03	1.3E+00	-5.6E+01
Global warming	kgCO _{2eq}	5.6E+05	2.0E+06	4.1E+03	-1.5E+06
Non-renewable energy	MJ primary	-5.1E+05	2.2E+07	5.4E+04	-2.2E+07
Mineral extraction	MJ surplus	3.3E+04	3.6E+04	3.4E+03	-6.6E+03

Table 2 displays the contribution by stage to the total potential impact in each category, something represented graphically in Fig. 4. As can be already observed, the AD plant is the process responsible for most of the environmental toll in all impact categories. In the Global warming category, the most impacting sub-process is the treatment of the digester sludge from the AD plant, responsible for 1.16E6 kgCO_{2eq} per FU. When it comes to the use of Non-renewable energy, the most impacting activity in the Anaerobic digestion stage is the transport of FW to the facilities, with a total consumption of 2.19E7 MJ per FU, followed by the digester sludge treatment with 9.89E6 MJ. In general, the waste treatment of the digester sludge and the transport of FW are the activities contributing the most to the potential environmental burden in all impact categories.

The reported negative values in Fig. 4 represent avoided emissions, understood as benefits to the environment, also called environmental credits, from the operation of the CHP plant. Such credits occur as the electricity and heat surplus have been modelled as avoided products to the techno sphere because they would be sold to the national electricity grid and nearby industries for thermal energy, preventing the use of such energy inputs the conventional energy sources in Colombia.

The environmental impact shares by the Mondonedo plant in the four main damage categories (Climate change, Ecosystem Quality, Human Health, and Resource use) [33] can be seen in Fig. 5. The aggregation of mid-point impact categories into damage categories is achieved using a specific set of characterization factors given by the chosen LCA method. As seen, the electricity and heat production at the CHP plant generates credits almost able to compensate for the burdens created by the other stages in the resource use and Climate change areas of concern. Yet, the benefits are not enough in the ecosystem quality and human health categories, and considerable potential impacts are produced. The *IMPACT 2002+* method enables weighting factors to develop a single score unit for all categories (ecopoints-Pt) to allow comparisons between the different damage categories. The comparison between categories enables us to identify which one is the most affected overall and totalize all of them, as done in Fig. 6.

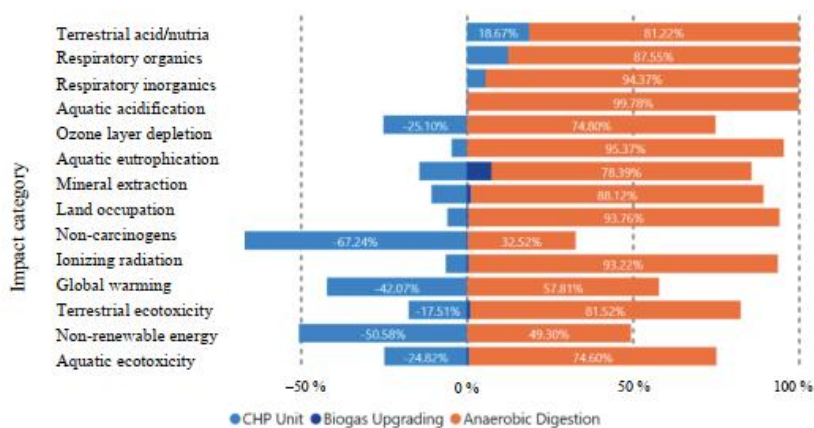

Fig. 4. Characterization results for the Mondonedo plant.

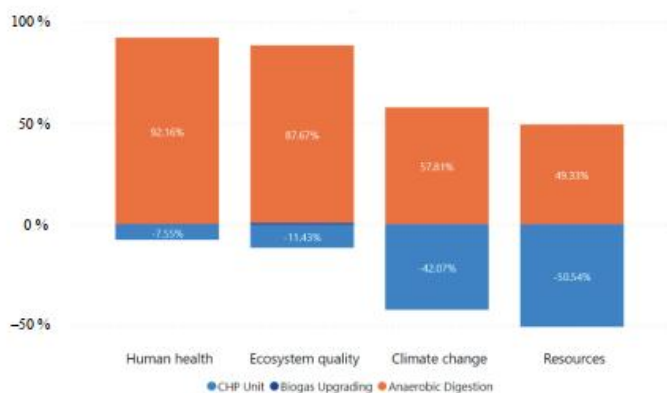

Fig. 5. Damage assessment result for the Mondonedo plant.

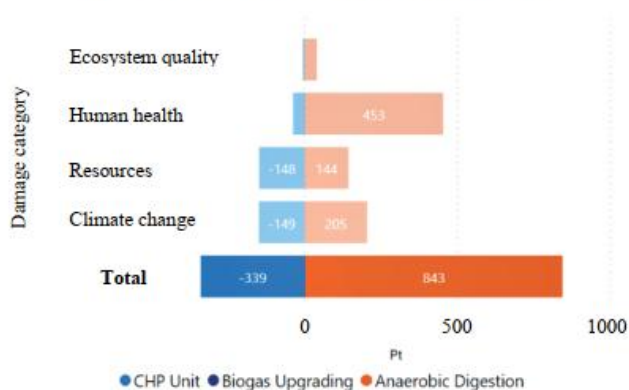

Fig. 6. Weighted totalized results for the Mondonedo plant.

Overall, the single total score for the Mondonedo plant is 506 Pt, with the digester sludge treatment as the most critical hotspot with 515 Pt, followed by transport of the sorted FW to the facilities with 247 Pt, and the construction of the AD plant with 79.8 Pt. The environmental benefits reported with a total of 339 Pt come from the electricity and heat production and are envisioned as avoided products with 219 and 217 Pt correspondingly.

3.1. C-LCC Results

For purchased equipment, market costs in USD 2020 values are taken from the database available in the *SuperPro Designer*® software. For the operational costs (OPEX) calculations, 2022 Colombian utilities' market prices are assumed for industrial water, softened water, and lubricating oil. In consumables, the packaged bed filling for water scrubbing (absorption column) is believed to be replaced three times per year due to clogging [43], and available market prices for random polypropylene packing material were used (11.0 USD/ft³). For Operation and Maintenance (O&M) expenses, equipment maintenance and labor costs were accounted for, bearing Colombia's type of equipment and wage conditions.

Considering the displayed CAPEX (see Table 2) and the OPEX structure, a C-LCC was performed for the proposed Mondonedo FW treatment plant. The revenues are obtained from electrical and thermal energy sales to the Colombian internal public market under the current trading conditions. The plant cash flow was calculated considering the revenues, OPEX, and the external waste treatment costs (digestate and waste oil). The annual payment of income tax (estimated at 32 % for Colombia) was calculated considering depreciation with a 4.0 % yearly inflation, estimated investment return with an annual interest rate of 6.0 %, and the plant cash flow.

TABLE 2. CAPEX SUMMARY

Type of cost	Value	Unit
Plant Equipment Costs (installed)	11 027.150	USD
Secondary costs	9 483.349	USD
Total Depreciable costs	20 510.499	USD
Direct costs	26 851.110	USD
Fixed Capital Investment	37 394.720	USD
Total Capital Investment	46 182.479	USD

For the project evaluation, three socio-economic indicators were estimated: Net Present Value (NPV), Internal rate of Return (IRR), and the Profit Index (PI). The evaluation dropped an NPV equal to USD 112 248 095, an IRR of 16.25 %, and a PI of 3.43, proving the project's economic feasibility.

3.2. S-LCA Results

The social pillar was evaluated through selected social indicators and considering the results of similar studies in landfills. It can be said that energy production from organic waste in a landfill contributes to the creation of legal jobs, which enhances fair wages, and supports the local economy as it encourages community association for the activities related to the collection and sorting of waste.

Additionally, it is believed that by doing a controlled separation of waste and by biomethane cogeneration, the health and safety conditions of workers can improve, as a result of labour formalization and the mandatory use of personal protection equipment and mechanisms for

the execution of activities within the landfill and energy plant, reducing the risks of affectations for local communities. It must be pointed out that, although the study projects new job creation as one of the positive impacts, local communities perceive that these jobs are excluding the local labour force and are often hiring professionals from other regions.

In safe and healthy conditions of local communities, the human health area presents an issue in the environmental evaluation. Thus, it is essential to evaluate end-of-pipe technologies to reduce the emissions of substances affecting the areas of respiratory organics and non-carcinogens to diminish this concern. It is believed that the proposed project would contribute to the economic development of the country as well as constitute a good sign from the governmental bodies and decision-makers towards their commitment to sustainability.

4. CONCLUSIONS

Evaluating energy projects requires an approach that integrates the different dimensions of sustainability, which is why the LCT tools are used in this work to assess environmental, economic, and social pillars for the Colombian context, something new at a regional level.

Using anaerobic digestion technologies in the Mondonedo landfill would promote organic waste management, increase social benefits like creating formal jobs, stimulating the local economy, and improving health and working conditions.

The cogeneration of heat and power using upgraded biomethane from the biogas generates a positive environmental impact in most of the mid-point categories evaluated. In the four areas of concern, energy production delivers environmental benefits, with the climate change and use of resources areas as the most positively impacted ones. Furthermore, the LCC evaluation plant showed that the proposed plant is economically feasible under the assumptions discussed and considering market prices in 2022.

The social impact of development such as the proposed one would positively impact the assessed stakeholders, especially local communities and workers. However, new job positions should involve local communities enhancing their participation and enrolment in formal jobs that allow them to improve their life quality.

Sustainable development programs in developing countries such as Colombia should prioritize the engagement of historically segregated communities or under monetary poverty conditions to improve the performance on socio-economic indicators such as equity, gender equality, fair wages, promotion of wellbeing, and other ones also included in the SDG from the UN.

Using multicriteria analysis methods, a sustainability performance comparison for similar landfills within the country would be desirable. However, the lack of data regarding landfill characterization and side-stream valorization proposal projects makes it difficult to undertake such a study.

ACKNOWLEDGEMENT

This work has been supported by the European Social Fund within the project "Support for the implementation of doctoral studies at Riga Technical University".

REFERENCES

- [1] Departamento Nacional de Planeación (DNP). Informe anual de Avance en la implementación de los ODS en Colombia (Annual progress report on the implementation of the SDGs in Colombia.). Bogotá: DNP, 2020. (in Spanish)
- [2] Gobierno de Colombia. Actualizada Contribución Previsada Determinada a Nivel Nacional de la República de Colombia (Updated Predicted Nationally Determined Contribution of the Republic of Colombia.). Colombia: NBC, 2020. (in Spanish)
- [3] Colombian Ministry of Environment and Development. Colombia está comprometida con la acción climática global (Colombia is committed to global climate action.). Bogotá: Ministerio de Ambiente y Desarrollo Sostenible, 2021. (in Spanish)
- [4] Colombian Congress. Law 1715. Bogotá: UPME, 2014. (in Spanish)
- [5] Mining and Energy Ministry of Colombia. Transición energética: un legado para el presente y el futuro de Colombia. 2020. [Online]. [Accessed: 3 January 2022]. Available: <https://www.minenergia.gov.co/libro-transicion-energetica#:~:text=En 2021%2C llegaremos a cerca,renovables en la matriz eléctrica>
- [6] Cámara de Comercio de Cali. Bioenergía Colombia. *Bioenergía/Plan de Acción Cluster de Bioenergía del Valle del Cauca*, 2022. [Online]. [Accessed 15 December 2021]. Available: <https://www.ccc.org.co/wp-content/uploads/2019/08/Plan-de-accio%cc%81n-Bioenergi%cc%81a.pdf>
- [7] Unidad de Planeación Minero-Energética (UPME). Plan Indicativo de Expansión de Cobertura de Energía Eléctrica 2016-2020 (Indicative Plan for the Expansion of Electricity Coverage 2016-2020.). Bogotá: UPME, 2016. (in Spanish)
- [8] INERCO Consultoría Colombia. Valorización Energética De Residuos: Proyecto WTE Colombia. Bogotá: UPME, 2018. (in Spanish)
- [9] Meneses-Jácome A., et al. LCA applied to elucidate opportunities for biogas from wastewaters in Colombia. *Water Sci. Technol.* 2015;71(2):211–219. <https://doi.org/10.2166/wst.2014.477>
- [10] Guedes Cubas do Amaral K., Mansur Aisse M., Collere Posetti G. R. Sustainability assessment of sludge and biogas management in wastewater treatment plants using the LCA technique. *Ambiente & Agua* 2019;14(5):1–14. <https://doi.org/10.4136/ambi-agua.2371>
- [11] Caicedo-Concha D. M., et al. The potential of methane production using aged landfill waste in developing countries: A case of study in Colombia. *Cogent Eng.* 2019;6(1):1–15. <https://doi.org/10.1080/23311916.2019.1664862>
- [12] Contreras M. D., et al. A look to the biogas generation from organic wastes in Colombia. *Int. J. Energy Econ. Policy* 2020;10(5):248–254. <https://doi.org/10.32479/ijeeep.9639>
- [13] Meneses-Jácome A., et al. Sustainable Energy from agro-industrial wastewaters in Latin-America. *Renew. Sustain. Energy Rev.* 2016;56:1249–1262. <https://doi.org/10.1016/j.rser.2015.12.036>
- [14] Guevara P. Red Iberoamericana de Aprovechamiento de Residuos Orgánicos en Producción de Energía. Bioenergía: Fuentes, conversión y sustentabilidad (Iberoamerican Program for the Use of Organic Residues in Energy Production, Bioenergy: Sources, conversion and sustainability.). Bogotá: Tescol, 2014. (in Spanish)
- [15] Unidad de Planeación Minero Energética (UPME). Guía práctica para la aplicación de los incentivos tributarios de la Ley 1715 de 2014 (Practical guide for the application of the tax incentives of Law 1715 of 2014.). Bogotá: UPME, 2014. (in Spanish)
- [16] Colombian Congress. Law 2099 of July 10th 2021. Bogotá: UPME, 2021. (in Spanish)
- [17] Unidad de Planeación Minero-Energética (UPME). Atlas of the energy potential of residual biomass in Colombia. 2020 [Online]. [Accessed 09.02.2022]. Available: <https://www1.upme.gov.co/siame/Paginas/atlas-del-potencial-energetico-de-la-biomasa.aspx#googtrans/gl/en>
- [18] Velásquez M. E., Rincón J. M. Estimación del potencial de conversión a biogás de la biomasa en Colombia y su aprovechamiento (Estimation of the biomass conversion potential to biogas in Colombia and its use.). Bogotá: UPME, 2018. (in Spanish)
- [19] Cámara de Comercio de Cali. El poder de la bioenergía en la competitividad el Valle del Cauca (The power of bioenergy in the competitiveness of Valle del Cauca.). Cali, 2018. (in Spanish)
- [20] Ministerio de Minas y Energía (República de Colombia). Boletín estadístico de minas y energía 2016–2020 (Statistical bulletin of mines and energy 2016–2020.). Bogotá: UPME, 2021. (in Spanish)
- [21] Universidad del Rosario. DOÑA JUANA. Un vecino incómodo (DOÑA JUANA. an awkward neighbor.). Bogotá: UR, 2018. (in Spanish)
- [22] Universidad Externado de Colombia. Relleno sanitario Doña Juana ¿una solución llena de problemas? (Doña Juana landfill, a solution full of problems?) Bogotá: UEC, 2019. (in Spanish)
- [23] Consorcio Relleno Sanitario Nuevo Mondoñedo (New Mondoñedo Sanitary Landfill Consortium). 2020 [Online]. [Accessed 24.01.2022]. Available: <https://nuevomondonedo.com/>
- [24] UNFCC. Nuevo Mondoñedo Landfill Gas Recovery, Flaring and Energy Production and Transformation for Leachate Evaporation. Project 10297, 2017 [Online]. [Accessed: 09.11.2021]. Available: <https://cdm.unfccc.int/Projects/DB/ICONTEC/1462894251.71/view>
- [25] Rogmans T., El-Jisr K. Designing Your Company's Sustainability Report. *Business and Society* [Online]. [Accessed: 12.03.2022]. Available: <https://hbr.org/2022/01/designing-your-companys-sustainability-report>

- [26] Yue L., Ruojuo L., Jingzheng R. Chapter 11- Fuzzy multicriteria decision making on ranking the biofuels production pathways. In *Biofuels for a more sustainable future. Life Cycle Sustainability Assessment and Multi-Criteria Decision Making* 2020:317–325. <https://doi.org/10.1016/B978-0-12-815581-3.00011-7>
- [27] Sala S. Chapter3- Triple bottom line, sustainability and sustainability assessment, an overview. In *Biofuels for a more sustainable future. Life Cycle Sustainability Assessment and Multi-Criteria Decision Making* 2020:47–72. <https://doi.org/10.1016/B978-0-12-815581-3.00003-8>
- [28] Mazzi A. Chapter 1- Introduction. Life cycle thinking. *Life Cycle Sustainability Assessment for Decision-Making* 2020:1–19. <https://doi.org/10.1016/B978-0-12-818355-7.00001-4>
- [29] Toniolo S., et al. Chapter 3- Life cycle thinking tools: Life cycle assessment, life cycle costing and social life cycle assessment. In *Life Cycle Sust. Assess. Decision-Making* 2020:39–45. <https://doi.org/10.1016/B978-0-12-818355-7.00003-8>
- [30] Rebitzer G., et al. Life cycle assessment Part 1: Framework, goal and scope definition, inventory analysis, and applications. *Environment International* 2004;30(5):701–720. <https://doi.org/10.1016/j.envint.2003.11.005>
- [31] Buxel H., Esenduran G., Griffin S. Strategic sustainability: Creating business value with life cycle analysis. *Bus. Horiz.* 2015;58(1):109–122. <https://doi.org/10.1016/j.bushor.2014.09.004>
- [32] Bartolozzi I., Rizzi F., Frey M. Are district heating systems and renewable energy sources always an environmental win-win solution? A life cycle assessment case study in Tuscany, Italy. *Renewable and Sustainable Energy Reviews* 2017;80:408–420. <https://doi.org/10.1016/j.rser.2017.05.231>
- [33] Jolliet O., et al. IMPACT 2002+: A New Life Cycle Impact Assessment Methodology. *International Journal of Life Cycle Assessment* 2003;8:324. <https://doi.org/10.1007/BF02978505>
- [34] International Organization for Standardization. ISO 14044:2006 Environ. Manag. Life cycle assessment – Requirements and Guidelines. Geneva: ISO, 2006.
- [35] Ardolino F., Parrillo F., Arena U. Biowaste-to-biomethane or biowaste-to-energy? An LCA study on anaerobic digestion of organic waste. *J. Clean. Prod.* 2018;174:462–476. <https://doi.org/10.1016/j.jclepro.2017.10.320>
- [36] Woon K. S., et al. Environmental assessment of food waste valorization in producing biogas for various types of energy use based on LCA approach. *Waste Manag.* 2016;50:290–299. <https://doi.org/10.1016/j.wasman.2016.02.022>
- [37] Kopsahelis A., et al. Life cycle assessment (LCA) of end-of-life dairy products (EoL-DPs) valorization via anaerobic co-digestion with agro-industrial wastes for biogas production. *J. Chem. Technol. Biotechnol.* 2019;94(11):3687–3697. <https://doi.org/10.1002/jctb.6174>
- [38] Ardolino F., Arena U. Biowaste-to-Biomethane: An LCA study on biogas and syngas roads. *Waste Manag.* 2019;87:441–453. <https://doi.org/10.1016/j.wasman.2019.02.030>
- [39] Zhou H., et al. Decarbonizing university campuses through the production of biogas from food waste: An LCA analysis. *Renew. Energy* 2021;176:565–578. <https://doi.org/10.1016/j.renene.2021.05.007>
- [40] Vitáček I., et al. Thermodynamics of combustion gases from biogas. *Res. Agric. Eng.* 2016;62(1):8–13. <https://doi.org/10.17221/34/2016-RAE>
- [41] Yliopisto J. Evaluation of Potential Technologies and Operational Scales Reflecting Market Needs for Low-cost Gas Upgrading Systems. UK: VALORGAS, 2013.
- [42] Ryckebosch E., Drouillon M., Vervaeren H. Techniques for transformation of biogas to biomethane. *Biomass and Bioenergy* 2011;35(5):1633–1645. <https://doi.org/10.1016/j.biombioe.2011.02.033>
- [43] Bauer F., et al. Biogas upgrading – Review of commercial technologies. 2013.
- [44] Stumm W., Morgan J. J. Aquatic chemistry: chemical equilibria and rates in natural waters. 3rd Edition. New York: Wiley, 1996.
- [45] Hullu S. S. J., Maassen J. Comparing different biogas upgrading techniques. Eindhoven: Eindhoven University of Technology, 2008.
- [46] Dragos D., Neamtu B. Sustainable Public Procurement: Life-Cycle Costing in the New EU Directive Proposal. *Eur. Procure. Public Priv. Partnersh. Law Rev.* 2013;8(1):19–30. <https://doi.org/10.21552/epppl/2013/1/159>
- [47] Bejan A. Economies of Scale. *Freedom and Evolution: Hierarchy in Nature, Society and Science*. Cham: Springer International Publishing, 2020:13–20. <https://doi.org/10.1007/978-3-030-34009-4>
- [48] Snegireva T., et al. Human potential in the system of sustainable development. *E3S Web of Conferences* 2019;134:03014. <https://doi.org/10.1051/e3sconf/201913403014>
- [49] United Nations. The sustainable development goals report 2019. New York: UN, 2019.
- [50] Benoit-Norris C. The Methodological Sheets for Sub-Categories in Social Life Cycle Assessment (S-LCA). *Pre Publ. Version. Methodol. Sheets Subcategories Soc. Life Cycle Assess* (S-LCA), 2018:2.
- [51] UNEP Setac Life Cycle Initiative. Guidelines for Social Life Cycle Assessment of Products and Organizations 2020. *Management* 2020:15(2).
- [52] Ruiz Restrepo M. A. Bioenergía, una alternativa energética sustentable para Colombia. Aplicación del Concepto Integrado de Sostenibilidad (ICoS) (Bioenergy, a sustainable energy alternative for Colombia. Application of the Integrated Concept of Sustainability.). Bogota: Universidad Nacional de Colombia, 2019. (in Spanish)
- [53] Goedkoop M., et al. Introduction to LCA with SimaPro. Amersfoort: PRé, 2016.

-
- [54] Wernet G., *et al.* The ecoinvent database version 3 (part I): overview and methodology. *Int. J. Life Cycle Assess.* 2016;21(9):1218–1230. <https://doi.org/10.1007/s11367-016-1087-8>
- [55] Humbert S., *et al.* IMPACT 2002 + : User Guide, 2002:21:42.
- [56] Diaz F., Pakere L, Romagnoli F. Life cycle assessment of low temperature district heating system in Gulbene region. *Environ. Clim. Technol.* 2020;24(2):285–299. <https://doi.org/10.2478/rtuct-2020-0073>

Article 6: Life Cycle Assessment of Low Temperature District Heating System
in Gulbene Region

Life Cycle Assessment of Low Temperature District Heating System in Gulbene Region

Fabian DIAZ^{1*}, Ieva PAKERE², Francesco ROMAGNOLI³

¹⁻³ Institute of Energy Systems and Environment, Riga Technical University, Azenes iela 12/1, Riga, LV-1048, Latvia

Abstract – New district heating system technologies have arisen in the last years to deliver economic and environmental benefits to residential and commercial buildings. The extensive ranges of equipment, energy sources, temperature profile configurations, size of the network, energy demand, and many other intrinsic variables, make it difficult to identify if a determined district heating option is potentially better than another in environmental terms. As for the economic evaluation, there are several tools decision-makers can rely on to assess environmental performance. The main challenge is to provide a holistic point of view for which lifespan and complexity of implementable, new technological systems can be an obstacle. For this reason, in this paper, a Life Cycle Assessment is performed upon a technical evaluation of several district heating configuration options for the Gulbene region in Latvia, where DH systems in most of the assessed parishes are already operating under medium temperature regimes, also known as third-generation district heating. The goal of the study is to understand the environmental impact of moving from the current DH system to a low temperature one. Results show a considerable environmental benefit if low-temperature profiles, combined with the use of renewable energy sources are adopted in the current DH systems. A hotspot analysis is also performed showing the use stage is the one carrying most of the burden across the project's lifetime, followed by infrastructure construction; also showing that the refurbishment of buildings does not play a major role in the total environmental impact contribution.

Keywords – Central heating; energy strategy; environmental impact; IMPACT 2002+, ISO 14044, sustainable development

Nomenclature

GHG	Greenhouse gases
LCA	Life Cycle Assessment
LCI	Life Cycle Inventory
LCIA	Life Cycle Impact Assessment
4GDH	Fourth Generation District Heating
3GDH	Third Generation District Heating
LTDH	Low Temperature District Heating
PES	Pilot Energy Strategy
APOS	Allocation at the Point of Substitution
Pts	The average impact in a specific category caused by or upon a person for one year

* Corresponding author.

E-mail address: Fabian-andres.diaz-sanchez@rtu.lv

©2020 Fabian Diaz, Ieva Pakere, Francesco Romagnoli.

This is an open access article licensed under the Creative Commons Attribution License (<http://creativecommons.org/licenses/by/4.0>), in the manner agreed with Sciendo.

1. INTRODUCTION

District heating (DH) systems can provide heat supply to communities various in size – from a small parish or community to whole cities. Although the most important aspect is selecting an energy source that delivers a higher cost-benefit than a conventional boiler or electric heating system [1], in this view the environmental aspect is a fundamental part to follow. For Latvia specifically, it is stated under the “Sustainable Development Strategy” goals [2] that a renewable and safe energy system must be reached by 2030 to include a 50 % of Renewable Energy Source (RES) share in the final energy consumption by implementing energy policies. Similar paths have been followed by many European countries in the last decade, where DH systems have evolved towards more sustainable systems [3].

In 2014, Connolly *et al.* [4] designed a heat strategy capable of reducing heating and cooling costs by 15 % in 2030 and 2050 by using the renewable heat potential in district heating systems. The study, among others, compared the costs and CO₂ emissions of their new energy strategy with the EU scenario of reference in the “European roadmap 2050” [5]. It was concluded that district heating is a vital technology for decarbonization paths in the EU energy system and should be considered. It has also been determined that further studies and research on district heating systems should focus on the policies and technological routes necessary to achieve economic and technical feasibility to successfully transition towards sustainable district-based systems [6]. These sustainable DH systems include not only the use of RES but also using low-temperature profiles in the DH distribution network. Conventional DH systems as they are known today, work within a wide range of temperature profiles for their supply and return lines (from 90 °C to 50 °C) [1]. On the other hand, low-temperature district heating (LTDH), also known as fourth generation district heating (4GDH) systems, works in the range of 50–20 °C [1].

It has been proved that 4GDH systems can reduce energy losses, balance renewable energy in electricity grids, use industrial excess heat that is usually eliminated by cooling technologies or released to the environment, and has powerful economic potential when implemented correctly [7]. There is the Swedish case, where Sernhed *et al.* (2018) [8], explain how despite Sweden’s DH system is almost fossil-free, the next challenge is to give use to low-temperature heat sources. They uncovered that the current DH technology needs a long-lasting modification to allow better utilization of renewable, recycled, stored, and waste heat [8]. Moreover, in 2017 Vigars *et al.* [9] showed the benefits in operational terms, which equipment in the DH system could obtain from working with network low temperatures return lines increasing their efficiency. Mathematical models to forecast and understand new equipment behaviour under reduced DH network temperature operation, have been already developed and tested successfully, proving again the benefits 4GDH technologies [10].

Implementing the essential modifications to DH systems and to the system structure and buildings, where the source of the thermal energy demand is generated, will carry an environmental burden that needs to be assessed. Studies addressing the bottleneck of heat production infrastructure challenges, and storing capacities, have already been undertaken [11]. However, the environmental toll of transitioning towards the analysed 4GDH has not been captured. A similar issue is found in the research made by Curtis *et al.* (2018) [12] where it is stated that the proximity to the thermal production facility is the most important factor in determining the DH upgrade in a residential area, whereas the environmental impact is disregarded. Due to the lack of holistic approaches considering sustainable development goals, it becomes necessary to implement methodological studies able to calculate the environmental impact of new 4GDH systems. By including within the

scope, all the activities related to infrastructure preparedness and construction, and the operational phase which involves not only the raw materials or fuel required to run a DH system but also the background processes contained in it and expanding the boundaries to also assess the expected changes in the residential and commercial buildings under different scenarios, the goal of fully assessing the environmental impact of these new 4GDH systems is settled.

2. LIFE CYCLE ASSESSMENT METHODOLOGY

One of the main motivations for the developing of new DH systems is the resulting environmental benefits, as such systems can reduce greenhouse gases (GHG) emissions, air pollution, ozone depletion, and acid precipitation among other advantages, by integrating RES, improving efficiency in equipment and moving from individual solutions to central heating systems. From the sustainable development point of view, DH systems are understood as a service, which makes it necessary to quantify the environmental impacts arising from it, since it is created and used to fulfil a need. All products (goods or services) have a life cycle, beginning with design, development, resource extraction, production (here there may exist several production phases, manufacturing of materials required for later production of the analysed product, transformation of raw materials, energy production, etc.), use or consumption, and the end of the life activities (collection, sorting, reuse, recycling, and waste disposal) [13]. The concatenation of all these activities along the life cycle results in environmental impacts due to resource consumption, emissions of substances into the environment, and some other environmental exchanges such as radiation or ionization.

Life Cycle Assessment (LCA) is recognized as the most powerful and widely used tool for undertaking holistic environmental sustainability assessments, as it is capable of assessing the product's environmental impacts from cradle to grave [14] on a multicriteria approach. The principle is to compute the materials and energy flow inputs and the emissions at all phases (stages) in the life cycle of a production process. LCA offers a broader perspective because it can be utilized to evaluate a wider range of environmental impact categories, beyond climate change, which is often the usual and only parameter considered when assessing environmental performance, particularly for energy production and distribution scenarios. One of the advantages of LCA is complementing local environmental impact assessments by analysing the impacts from a global perspective, therefore avoiding the so-called "burden-shifting" [15]. As a result, LCA is understood as a methodological framework to estimate the environmental impacts coming from the life cycle of a determined product. Such impacts can be classified in climate change, stratospheric ozone depletion, tropospheric ozone creation (smog), eutrophication, acidification, toxicological stress on human health and ecosystems, resource depletion, water use, land use, noise, and others [16].

Methodologies to implement an LCA vary among studies, but the most common one remains to be the LCA ISO standard 14040 and 14044. The ISO 14040 (1997) describes the principles and framework for LCA while ISO 14044 presents requirements and guidelines to perform the assessment. According to the framework found in ISO 14040, a complete life cycle, with its associated material and energy flows is called a product system. Then, collecting, tabulating, and performing a preliminary analysis of emissions and resource consumption is called Life Cycle Inventory (LCI), and most of the times it is necessary to calculate and interpret indicators of the potential impacts associated with the exchange of such flows with the natural environment, thus, performing a life cycle impact assessment (LCIA).

In ISO 14044, the main four steps included in the LCA methodology are described: goal and scope, life cycle inventory, life cycle impact assessment, and life cycle interpretation [17]. Defining the goal and scope is the first step in an LCA, the objective is to make clear why the LCA methodology is performed and which phases of the production processes are analysed. Due to the iterative LCA nature, the scope is susceptible to redefinitions during the study. The goal and scope must define the intended application, the product system, functional unit (FU), system boundaries, LCIA methodology, assumptions and limitations, and some other data requirements. The second step is the LCI, where inventory is gathered and quantified according to the defined FU. In this step, the stages and the data collection and calculation techniques are described in detail. The third step, the LCIA, includes the collection of indicator results for the different impact categories, which together represent the LCIA profile for the product system. Such results are categorized in the aforementioned impact categories. It is at this point, where sensitivity analysis can be performed to determine how changes in data and methodological choices may affect the results. Finally, in the Life Cycle Interpretation, several elements are considered: identification of significant issues based on results, evaluation of consistency and sensitivity checks, and discussion of conclusions, limitations, and recommendations.

The LCA methodology has already been used in evaluating the environmental impact of district heating solutions in the past. In 2009, Oliver-Sola *et al.* [18], analysed the DH system's infrastructure in a neighbourhood using the Ecoinvent database and Gabi software finding that the main impacts are located in the power plants and dwellings instead of in the pipeline network. However, this study lacked heat consumption and losses during the use phase stage. In 2017, LCA studies conducted by Bartolozzi *et al.* [19], showed significant reductions in GHG emissions when renewable energy sources (RES) are integrated into heating and cooling alternatives, versus traditional individual systems. Using comparative LCA on different DH systems as a decision-making tool has also been done under the life cycle management approach (LCA plus Life cycle costing) by Ristimäki *et al.* [20]. In their study, four DH systems scenarios were evaluated and the one with the best environmental score turned out to be the most viable in economic terms and carbon emissions reduction, despite being the one with the highest initial investment. Many other studies can be found in the literature, where the energy production phase of DH systems using different energy sources including RES are compared with conventional ones. In the case study covered in this project, a holistic approach is intended by evaluating in the long term, the environmental impact of infrastructure, and the use phase of DH systems as a decision-making tool.

Following the LCA methodology recommended by ISO 14044, the selected method for processing and present the results was IMPACT 2002+. This method offers several advantages versus classic impact assessments-oriented ones such as EDIP or CML, where the outputs are arranged in midpoint categories using characterization factors, which restrict the quantitative model to relatively early stages in the cause-effect chain, and also when compared to only damage oriented methodologies such as ReCIPE or Eco-indicator 99, where the cause-effect chain is quantified by the model using endpoint characterization factors. IMPACT 2002+ merges the advantages of both schools of methodologies, by grouping analogous category endpoints and building a set of damage categories, but also using midpoint categories, with each one of them related to one or more damage categories [21].

3. LCA CASE STUDY

Gulbene region comprises the city Gulbene and 6 parishes that nowadays have the installed district heating systems working under what can be called third-generation technology that is also the state of the art for more of the district heating systems currently working in Northern and Eastern Europe. Nevertheless, while seeking to meet the aforementioned plans, Gulbene region has started to work towards a more energy-efficient performance by the development of a Low Temperature District heating network, initially implemented in the Belava parish [22]. Under the Pilot Energy Strategy (PES) for Gulbene region, the 6 parishes including Gulbene municipality have been considered for developing low-temperature or also called fourth generation district heating (4GDH) systems, and initial studies assessing technical and economic feasibility have already been structured for different future scenarios [23]. However, the environmental load of probable future scenarios should be analysed and compared to the current heat production and distribution practice, to quantify the impact change in different areas of concern from those different proposed options for development.

3.1. Goal and scope definition

3.1.1. Goal

The goal of this study is to assess the environmental impacts of the baseline scenario for the current DHS in Gulbene region and a possible future scenario where temperature profiles in the distribution network are lowered, basically due to insulation improvements in the buildings, as part of a new Low Temperature District Heating system (LTDH).

The main objective of the project is to show the effects of moving towards transition from a 3GDH system to a 4GDH system. The LCA study will provide, in junction with an economic assessment, a reliable decision-making tool providing consistent thresholds for the selection of the optimal technological solution in line with "Latvia's Sustainable Development Strategy 2030" [2].

3.1.2. Scope

The scope requires a clear description of the function and functional unit, system boundaries, methodology, and data requirements in order to sufficiently address the stated goal. As said before, an attributional model is performed for this study to evaluate the environmental load of the DH system baseline scenario with the proposed upgrade to an 4GDH future scenario. The timeframe of the study only includes existing technologies and described technologies in this project. Hence, the effect of new technologies will not be taken into consideration. Future trends in insulation improvements across the pipelines that comprise the distribution network, resulting in heat loss reductions, or in the boiler house, are also not considered other than those explicitly discussed within the project.

Among the different scenarios comprised in [23], some of them evaluate not only the reduction in the temperature profile across the network but also the inclusion of new customers, decoupling of some buildings while maintaining the same temperature profile for the supply and return lines of the DH network. Within this study, only scenarios falling under the definition of 4GDH were analysed and compared to the baseline one.

For the baseline scenario, the current technology, data for calculations, fuels and networks described in [23] were used for modelling activities as part of the background data. Foreground data was obtained from [22] and then it was assumed that similar infrastructures are encountered or developed in the other Gulbene parishes. The distribution network

temperature is usually assumed as 70 °C for the supply pipelines and 45 °C for the return lines, although each parish has its own temperature schedule.

The LCA performed in this project was completed using Simapro 9.0 software integrated with Ecoinvent 3.0 database.

3.1.3. Functional unit

A functional unit (FU) is a measure of the performance of the functional outputs of the product system and its primary purpose is to provide a reference to which the inputs and outputs are related. This reference is necessary to ensure the comparability of LCA results. The definition of a functional unit must hence include both the quantitative and the key qualitative aspects to avoid subjectivity when subsequently defining an equivalence.

In this case, the functional unit is the operation and maintenance of the DH system over an assumed time horizon for delivering the required heat demand of the different Gulbene parishes and the municipality including infrastructural works required for heat distribution in each scenario. This includes any construction or renewing work required either for the baseline or future scenarios, such as boiler house construction or maintenance, the deployment of required new pipelines and heat pump installation or refurbishment, and insulation materials for the customer's buildings.

3.1.4. System boundaries

The parishes under evaluation are located in north-eastern Latvia in the Vidzeme region and the heating season in Gulbene, in accordance with Cabinet Regulation No. 338 "Regulations on Latvian Construction Standard LBN 003-15 "Building Climatology", is 209 days in duration with an average outdoor air temperature of -1.4 °C [23]. The duration of the heating season is based on the assumption that heating in the buildings is switched on when the average five-day outdoor air temperature is below 8 °C and accordingly switched off when the five-day average temperature is above 8 °C.

The system boundaries comprehend the construction of boiler houses, including energy and raw materials required for all equipment and accessories, the transport of materials for construction, and the energy required for it. Within the assemblies for the boiler house, nodes, pumps, taps and DH pipeline networks, materials, and equipment susceptible to replacement during the lifespan of the project are also included. Construction of solar plants, heat pumps, accumulation tanks, as elements, energy, and processes required for their construction, are also considered.

As can be seen in Fig. 1, for the operational phase, the fuel and electricity required to run the boiler house, pumps, and other equipment is accounted, including the extraction and transport of fuels. Nevertheless, operations related to non-schedule maintenance and repairs are not included due to their intrinsic feature of uncertainty and to avoid overestimating impacts. The replacement of equipment such as recirculation pumps during the lifespan of the project, however, are considered.

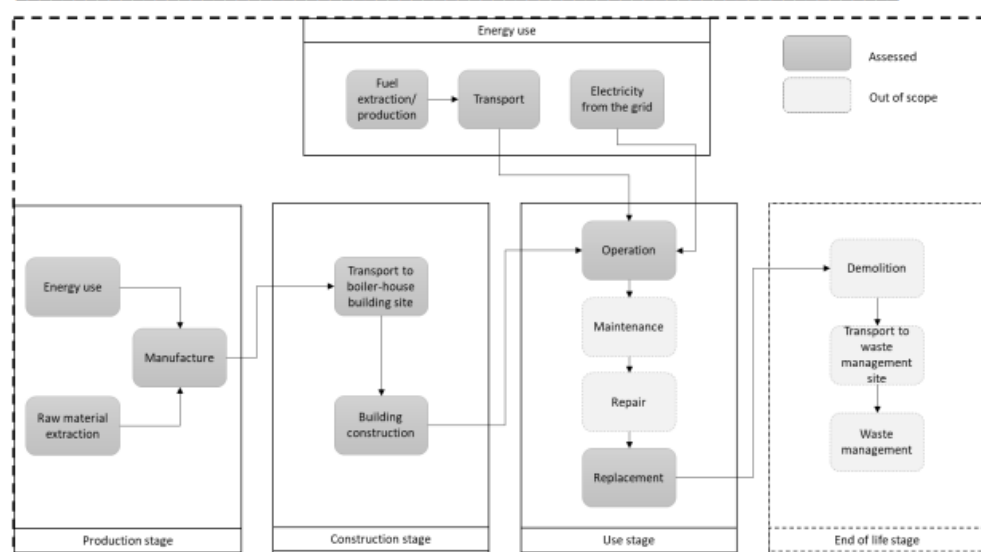

Fig. 1. System boundaries on the supply side.

The service life or intended time horizon is for 25 years from 2020, hence only available technologies at the moment of writing this document are considered within the study. The end of life stage is not considered at all in this study, as the useful life of a DH system depends on many variables such as governmental policies, the technological diffusion of new technologies, rate of change in population (demand side), and maintenance of the network and boiler house.

Regarding boundaries on the demand side, the approach for the residential or public buildings gate to grave perspective and only repair/replacement material and activities within the use stage are considered, as consumer buildings are already in operation, connected to a 3GDH system and all that is required for adopting a 4GDH system, is the essential refurbishment to reduce the specific heat consumption in terms of kWh/m² per year. As the useful life of a residential or public building can be even longer than the one for a boiler house, the end of the life cycle is also out of the boundaries of this study.

3.1.5. Limitations and Assumptions

Among the limitations that apply for all parishes and scenarios, the main one to consider is the technology deployed in them, as only those currently available at a commercial level are considered. Most data used for modelling was found in the Ecoinvent database 3.0, and decommissioning or waste treatment for baseline scenarios are not considered. Some materials used for the assemblies might account for waste scenarios and would be mentioned when it happens.

In order to account for the whole impact of the assembly and operation of the district heating network, construction materials, equipment, and raw materials are included for all scenarios, this means the construction phase is within the boundaries as described in [23]. Nevertheless, this construction phase and all activities and materials are subject to data availability, which is limited due to the fact that all future scenarios are only proposals at the time this study was made, so detailed plans for the reconstruction of the boiler house are not available. The

distribution network, nodes, taps and pumps suffer from the same lack of information, as only basic data regarding pipeline length and diameter are available, hence, it was necessary to use the assembly data gathered in [23] for Belava parish, and use the same record for the modelled parishes in this study. This assumption is made since Belava is a parish within the Gulbene region and it is included in the Pilot energy strategy project.

For baseline scenarios:

- Only base load boilers are used.
- No changes in distribution network temperature profiles or ΔT between supply and return lines.
- No changes in insulation technologies along the network, maintaining the same heat losses trends.
- After any equipment replacement or maintenance, and renovation, the same boiler technology is used, using the same fuel type and consumption rate.
- A low calorific value of 3.5 MWh/ton of woodchips is used for calculations.
- A boiler efficiency of 89 % is used for the whole-time horizon [23].
- Calculations for the amount (tonne) fuel consumption was carried out considering previously mentioned values.
- No decommissioning phase was considered.

For 4GDH scenarios:

- Steady production and heat demand profile during the study lifetime.
- There are no changes in temperature profiles after the 4GDH system implementation.
- Steady production and heat demand profile during the study lifetime.

3.2. Life cycle inventory (LCI)

As the current DH infrastructure of each parish varies in terms of the type of boiler, fuel and furnace, and boiler size, the infrastructure data was taken from Belava parish [22] since this one was chosen as the Pilot development parish for assessing an 4GDH system in the Gulbene Region. The main boiler house structure, pipelines, DH nodes and other accessories such as valves, pumps and taps, were adjusted according to the size or length of each one described in [23] as long as actual detailed design engineering data for future renovation or refurbishment of these structures are not yet available and economic feasibility for most of the projects is still ongoing.

As described in the LCA of the Pilot energy strategy report for Belava, the data for common assemblies (pipelines, boiler houses, nodes and materials for building refurbishment) were gathered from certificates of manufacturers and then grouped into the corresponding material and processes within the Ecoinvent 3 database. Some DH assemblies have an equivalent input object in the Ecoinvent 3 database, but many do not. Such equipment, apparatus or accessories missing in the database, were entered as the amount and materials required for their production plus the process required to construct the assembly.

The whole inventory gathered for the LCA on the PES was divided into stages, for organization and conceptual purposes. For the construction stage, the main groups, basic for any DH system are pipelines, boiler house, DH nodes, pumps and accessories, furnaces, and accumulation tanks. Other assemblies were built for each parish and scenario model, such as solar plants, furnaces, accumulation tanks and containers (for small capacity pellet boilers when necessary). It must be mentioned that these groups only account for the production and construction stage (see Fig. 1) as selected objects from the Ecoinvent 3 database correspond to items allocated at the point of substitution (APOS). Thus, the use stage, including operation

of the DH assemblies, and the energy use phase which contains the fuel extraction or production, transport to boiler house and electricity or other energy use, is part of another assembly within the model, named “operational phase” in this LCA model. The same approach was used for the user side, with the building refurbishment required for accepting low temperatures under the future 4GDH scenarios.

A general example of how the assemblies were designed for inventory input is shown in Table 1. The summary of stages/processes about a particular parish assembly which is modelled in Simapro is displayed in Table 2.

TABLE 1. OPERATIONAL PHASE FOR STARI PARISH - 4GDH SCENARIO

Materials or Assembly	Amount	Unit
Roundwood, parana pine from sustainable forest management, under bark {GLO} market for APOS, U	1194	m ³
Processes	Amount	Unit
Heat, district or industrial, other than natural gas {CH} heat production, hardwood chips from forest, at furnace 300 kW APOS, U	900	MWh
Electricity, medium voltage {LV} market for APOS, U	23.1	MWh

As can be seen in Table 2, assemblies such as DH pipelines, and nodes, are adjusted to the size or length of the specific parish taking as a base, the assembly inventory from Belava parish. The operational stage is entered considering [23], which contains the inventory of fuels and materials required for a year of operation under the scenario described in the previous section.

TABLE 2. STARI 4GDH SCENARIO MODEL

Material/Assemblies	Amount, pieces
New Boiler House - No furnace	1
Old District heating Pipelines	0.61
DH nodes	0.61
Boiler pumps, taps, heat m., exch. & flow device	1
Node pumps and taps	0.61
Pipeline pumps, taps, heat meters, exch., flow d	0.61
Stari 4GDH Scenario Op. Phase	25
Building renovation assembly	2353.3
Intermodal shipping container, 20-foot {GLO} market for APOS, U	1
Furnace, pellets, with silo, 300kW {GLO} market for APOS, U	0.83
Hot water tank, 600l {GLO} market for APOS, U	2.1

The inventory for building renovation assembly, comprehend the materials required for lowering the average specific heat consumption in a determined building from the current state, down to the desired one in order for the inhabitants to enjoy the same temperature comfort than achieved under the actual 3rd generation DH system. The principle is simple, the better the insulation, the lower the heat permeability (or heat loss), resulting in a lower specific heat consumption per square meter. Typical materials for building refurbishments towards 4GDH, and their environmental impact when used in these projects, are listed in [24]

[25] and [26]. The average specific heat consumption for each parish under study is found in [23], as well as the calculated specific heat consumption required for future low-temperature DH scenarios, having in mind the new temperature operational schedules in each one of them, which are close to 65–45 °C for supply and return lines respectively. In order to create a material inventory for the refurbishment activities in the potential buildings under a possible 4GDH future scenario, previous projects for building renovations in Latvia were researched, finding two with similar specific heat consumption values to those in Gulbene region (125–180 kWh/m²) [27].

A list of materials and amounts (kg) required for the renovation of 1 square meter was created and then adjusted to the different parishes in the present model (i.e. assembly “Building renovation” in Table 2) considering two variables, the total heated area and the gap between its current and future or desired specific heat consumption, which is usually between 70–90 kWh/m² for the modelled parishes. The assembly built to refurbish 1 m² and holding a capacity to reduce the specific heat consumption in around 115 kWh/m² is shown in Table 3.

Other assemblies such as furnaces and accumulation tanks are entered independently and according to the foreground data found in [23]. Such assemblies, including the use stage (operational phase) and the building renovation one, encompasses the summary of the full scenario to model, as seen in Table 2. Therefore, information for each parish is elaborated in two tables, one for the baseline scenario and another one including the building refurbishment and changes to the DH system (4GDH scenario).

TABLE 3. BUILDING RENOVATION ASSEMBLY

Material	Amount, kg/m ²
Polystyrene, extruded	0.62
Adhesive mortar	2.36
Gypsum plasterboard	5.80
Glazing, double, U<1.1 W/m ² K, laminated safety glass	0.20
Alkyd paint, white, without solvent, in 60 % solution state	0.34
Stone wool	51.36
Epoxy resin, liquid	9.68
Glass fiber	0.46
Glued laminated timber, for indoor use	0.01
Orthophthalic acid based unsaturated polyester resin	0.06
Steel, chromium steel 18/8	0.04
Soil for construction	64.46
Sand	11.49
Polystyrene foam slab for perimeter insulation	1.22
Concrete, normal	0.04
Acrylic filler	0.44
Ceramic tile	0.19

3.3. Life Cycle Impact Assessment and Interpretation

The LCI gathered was used for the simulation in Simapro in accordance with the defined functional unit. The following results are presented in a comparative way for the baseline and for the proposed 4GDH scenarios. First, the environmental impact assessment is presented at midpoint level (kg of substance equivalent) in Table 4 where specific midpoint categories results are displayed; then a damage assessment graph is presented for comparing the environmental toll of each Life Cycle stage in the different endpoint impact categories or areas of concern. The Life cycle stages have been divided into three groups: 1) construction phase including the production stage and transport of materials required for building the DH system; 2) operational phase including the energy use and operational processes for running a DH system; 3) building renovation accounting for the materials and its transport, for refurbishment at the end-user side. After analysing the life cycle stages, a damage assessment is shown in terms of Eco-indicator points, kPt, in relation to the FU. This damage assessment presents result in the main four areas of concern evaluated within the IMPACT 2002+ methodology: human health, ecosystem quality, climate change and resources. Finally, within the parishes and scenarios evaluation, hotspots are identified by comparing the Life Cycle stages and their total environmental burden.

TABLE 4. CHARACTERIZATION RESULTS COMPARISON BETWEEN DH TECHNOLOGIES

Impact category	Unit	3GDH	4GDH	Change
Carcinogens	kg C ₂ H ₃ Cl eq	2 595 945	2 596 420	474
Non-carcinogens	kg C ₂ H ₃ Cl eq	12 830 261	12 268 175	-562 086
Respiratory inorganics	kg PM _{2.5} eq	608 624	276 023	-332 601
Ionizing radiation	Bq C-14 eq	1.28E+09	1.25E+09	-2.99E+07
Ozone layer depletion	kg CFC-11 eq	12.3	10.3	-2.0
Respiratory organics	kg C ₂ H ₄ eq	116 518	94 036	-22 483
Aquatic ecotoxicity	kg TEG water	9.71E+10	9.25E+10	-4.60E+09
Terrestrial ecotoxicity	kg TEG soil	3.43E+10	3.26E+10	-1.72E+09
Terrestrial acid/nutri	kg SO ₂ eq	5 794 645	4 625 667	-1 168 978
Land occupation	m ² org. arable	95 823 050	40 678 584	-55 144 466
Aquatic acidification	kg SO ₂ eq	950 161	802 406	-147 755
Aquatic eutrophication	kg PO ₄ P-lim	91 312	89 408	-1904
Global warming	kg CO ₂ eq	85 935 081	74 669 357	-11 265 724
Non-renewable energy	MJ primary	1.56E+09	1.38E+09	-1.75E+08
Mineral extraction	MJ surplus	6 846 417	7 056 832	210 415

Implementation of Low Temperature District Heating system has proven to have an overall environmental benefit in almost all categories but *carcinogens* and *mineral extraction*, where the increase related to the development of a 4GDH system is in the order of 0.02 % and 2.98 %, respectively. On the other hand, the *respiratory inorganics* category shows a 54.65 % reduction, *Respiratory organics* and *Terrestrial acidity* have a 20 % reduction and *land occupation* category has the largest decrease with a reduction in the required area for extracting raw materials of 55 144 466 m², a 57.55 % drop. The changes per impact category can be seen in Fig. 2.

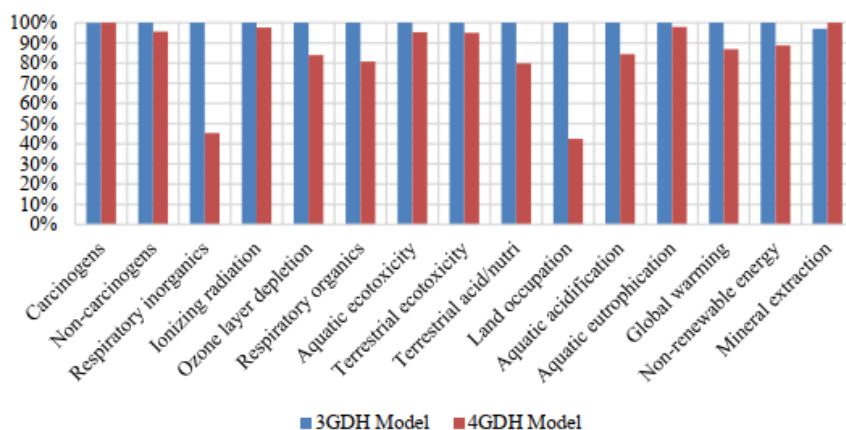

Fig. 2. Characterization comparison between impact categories.

The life cycle stages and their associated environmental toll is shown in Fig. 3, where the operational phase under the current circumstances (3rd generation district heating system) is easily identified as the main hotspot among the stages. On the other hand, the refurbishment required on the end-user side has little impact when compared to other life cycle phases.

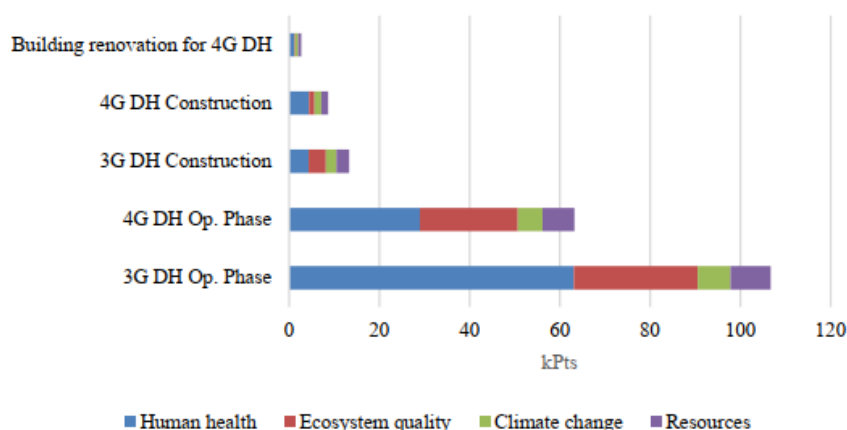

Fig. 3. Damage assessment for life cycle stages.

The aggregated difference at endpoint categories, or areas of concern, is shown in Fig. 4. In the human health area, the one with the highest environmental toll, the reduction of moving from a 3GDH to a 4GDH system, is equal to 50 %. The total environmental score for the human health area under the current conditions in Gulbene region, deliver 66.24 kPts for the analysed FU, while under a 4GDH system the resulting score is 33.18 kPts. Although the reduction percentage in other areas are not as high as the observed for the human health one, still benefits from moving towards a 4GDH are found in the three remaining areas under the IMPACT 2002+ methodology.

It is important to clear up the concept of a point (Pt) in the IMPACT 2002+ methodology. A point is equal to the average impact caused by a person in a specific category during one year in Europe, while on the contrary, for the human health category, a point represents the average impact on a person in the course of one year. Thus, if an impact of 3 points in climate change, ecosystem quality or resources is found, it would exemplify the average annual impact caused by 3 Europeans.

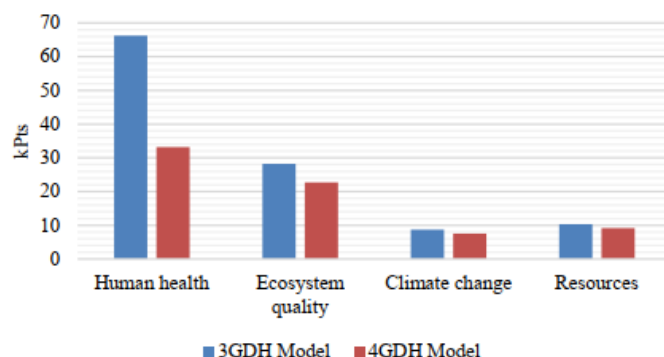

Fig. 4. Weighted damage assessment comparison at end point categories.

Finally, the total single score for each model is plotted in Fig. 5, where the combined results in each area of concern are presented. The 3GDH system gives a total score of 113.45 kPts, and the 4GDH system 72.62 kPts, showing a total reduction of 40.83 kPts, representing an environmental impact reduction of 36 %.

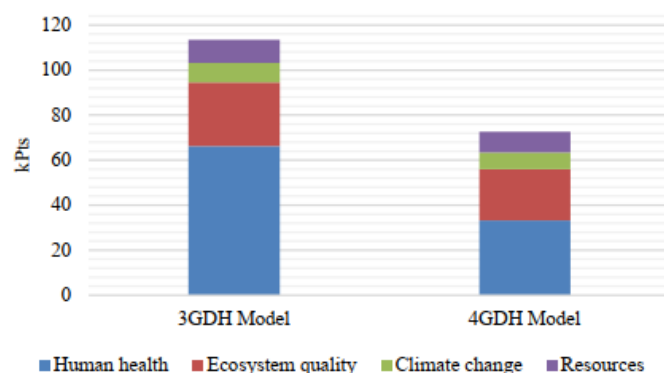

Fig. 5. Weighted damage assessment comparison at end point categories.

4. CONCLUSIONS

Results from the LCA undertaken in this study show the potential benefits in almost all impact categories recommended in [17], with only the mineral extraction category (represented as “MJ surplus”, see Table 4) showing an actual negative impact of moving from the current district heating system running in the Gulbene region to a 4GDH system. This is

due to the necessity of refurbishment in the buildings where a 4th generation DH system is to be deployed, as materials required for it (see Table 3) represents an energy increase from the extractive activities, and to the fact that there are parishes where the thermal energy consumed during the heating season is nowadays being purchased from external companies but under the 4GDH scenario, the construction of new facilities and local heat production activities are considered.

The environmental benefit of implementing low-temperature district heating systems comes mainly from reduction in the amount of fuel required for operation and from moving from fossil non-renewable energies towards renewable ones as biomass for this case. The use of renewable energies is the key aspect in 4GDH systems, since it was determined from the results for the Lizums parish, that using fossil fuels, even for a low-temperature scenario, results in higher damage values to the resources and climate change areas than in other parishes where thermal energy is 100 % obtained from renewable sources such as biomass.

The building refurbishment activity is another aspect to pay special attention to. The amount of materials required to lower the specific heat consumption per area depends on the current building insulation condition. If the area to refurbish is too large, and the initial specific heat consumption value is also high, the environmental impact from this activity could be quite large, even larger than the DH system construction itself (as it was identified during single LCA for the 4GDH scenarios in some parishes). However, if 3GDH systems are already operating in a municipality, the aggregated impact from undertaking refurbishment tasks in the buildings will be overlapped in the long term by the benefits of operating under a lower temperature profile when the heat is generated from biomass.

ACKNOWLEDGEMENT

This work is supported by the European Commission through the EU INTERREG Baltic Sea Region Project Number R063 Low Temperature District Heating for the Baltic Sea Region” (LowTEMP). The contents of this publication are the sole responsibility of the authors and can in no way be taken to reflect the views of the Riga Technical University or the European Commission. The authors would like to thank Mrs. Dagnija Blumberga, Director and professor at the Institute of Energy Systems and Environment for encouraging the development of this work.



REFERENCES

- [1] Wiltshire R. *Advanced District Heating and Cooling (DHC) Systems*. Woodhead Publishing, 2016.
- [2] Saeima of the Republic of Latvia. “Sustainable Development Strategy of Latvia until 2030”, 2010. [Online]. [Accessed 29.04.2020]. Available: https://www.pkc.gov.lv/sites/default/files/inline-files/LIAS_2030_en_1.pdf
- [3] Mazhar A. R., Liu S., Shukla A. A state of art review on the district heating systems. *Renewable and Sustainable Energy Reviews* 2018;96:420–439. <https://doi.org/10.1016/j.rser.2018.08.005>
- [4] Connolly D. *et al.* Heat roadmap Europe: Combining district heating with heat savings to decarbonise the EU energy system. *Energy Policy* 2014;65:475–489. <https://doi.org/10.1016/j.enpol.2013.10.035>
- [5] European Climate Foundation. “Roadmap 2050”, April 2010. [Online]. [Accessed 28.04.2020]. Available: https://www.roadmap2050.eu/attachments/files/Volume1_fullreport_PressPack.pdf
- [6] Lake A., Rezaie B., Beyerlein S. Review of district heating and cooling systems for a sustainable future. *Renewable and Sustainable Energy Reviews* 2017;67:4147–425. <https://doi.org/10.1016/j.rser.2016.09.061>
- [7] Thellufsen J. Z., Nielsen S., Lund H. Implementing cleaner heating solutions towards a future low-carbon scenario in Ireland. *Journal of Cleaner Production* 2019;214:377–388. <https://doi.org/10.1016/j.jclepro.2018.12.303>

- [8] Semhed K., Lygnerud K., Werner S. Synthesis of recent Swedish district heating research. *Energy* 2018;151:126–132. <https://doi.org/10.1016/j.energy.2018.03.028>
- [9] Vigants E., Prodanuks T., Vigants G., Veidenbergs I., Blumberga D. Modelling of Technological Solutions to 4th Generation DH Systems. *Environmental and Climate Technologies* 2017;20(1):5–23. <https://doi.org/10.1515/rtuect-2017-0007>
- [10] Bolonina A., Bolonins G., Blumberga D. Analysis of the Impact of Decreasing District Heating Supply Temperature on Combined Heat and Power Plant Operation. *Environmental and Climate Technologies* 2015;14(1). <https://doi.org/10.1515/rtuect-2014-0013>
- [11] Brange L., Englund J., Semhed K., Thern M., Lauenburg P. Bottlenecks in district heating systems and how to address them. *Energy Procedia* 2017;116:249–259. <https://doi.org/10.1016/j.egypro.2017.05.072>
- [12] Curtis J., McCoy D., Aravena C. Heating system upgrades: The role of knowledge, socio-demographics, building attributes and energy infrastructure. *Energy Policy* 2018;120:183–196. <https://doi.org/10.1016/j.enpol.2018.05.036>
- [13] Rebitzer G., Ekvall T., Frischknecht R., Hunkeler D., Norris G., Rydberg T., Schmidt W., Suh S., Weidema B., Pennington D. Life cycle assessment Part 1: Framework, goal and scope definition, inventory analysis, and applications. *Environment International* 2004;30(5):701–720. <https://doi.org/10.1016/j.envint.2003.11.005>
- [14] Buxel H., Esenduran G., Griffin S. Strategic sustainability: Creating business value with life cycle analysis. *Business Horizons* 2015;58(1):109–122. <https://doi.org/10.1016/j.bushor.2014.09.004>
- [15] Bartolozzi I., Rizzi F., Frey M. Are district heating systems and renewable energy sources always an environmental win-win solution? A life cycle assessment case study in Tuscany, Italy. *Renewable and Sustainable Energy Reviews* 2017;80:408–420. <https://doi.org/10.1016/j.rser.2017.05.231>
- [16] Jolliet O., Charles M. M. R., Humbert S., Payet J., Rebitzer G., Rosenbaum R. IMPACT 2002+: A New Life Cycle Impact Assessment Methodology. *International Journal on LCA* 2003;8(6):324–330. <https://doi.org/10.1007/BF02978505>
- [17] ISO. ISO 14044:2006 Environmental management — Life cycle assessment — Requirements and guidelines, 2006.
- [18] Oliver-Solà J., Gabarrell X., Rieradevall J. Environmental impacts of the infrastructure for district heating in urban neighbourhoods. *Energy Policy* 2009;37(11):4711–4719. <https://doi.org/10.1016/j.enpol.2009.06.025>
- [19] Bartolozzi I., Rizzi F., Frey B. Are district heating systems and renewable energy sources always an environmental win-win solution? A life cycle assessment case study in Tuscany, Italy. *Renewable and Sustainable Energy Reviews* 2017;80:408–420. <https://doi.org/10.1016/j.rser.2017.05.231>
- [20] Ristimäki M., Saynajoki A., Heinonen J., Junnila S. Combining life cycle costing and life cycle assessment for an analysis of a new residential district energy system design. *Energy* 2013;63:168–179. <https://doi.org/10.1016/j.energy.2013.10.030>
- [21] Humbert S., Schryver A. D., Bengoa X., Margni M., Jolliet O. IMPACT 2002+: User guide, Quantis, 2012.
- [22] Feofilovs M., Pakere I., Romagnoli F. Life Cycle Assessment of Different LowTemperature District Heating Development. *Environmental Climate Technologies* 2019;23(2):272–290. <https://doi.org/10.2478/rtuect-2019-0068>
- [23] Ekodoma. Strategy for low temperature district heating system implementation in Gulbene municipality. Gulbene, 2019.
- [24] Stephan A., Crawford R. H., Myttenaere K. D. A comprehensive assessment of the life cycle energy demand of passive houses. *Applied Energy* 2013;112:23–34. <https://doi.org/10.1016/j.apenergy.2013.05.076>
- [25] Angelis E. De, Dotelli G., Pittau F., Torre A. La, Porcino C., Pansa G., Villa N. LCA and LCC based Energy Optimization of Building Renovation Strategies. In *SB13 GRAZ Sustainable Building Conference 2013*, Graz, 2013.
- [26] Bull J., Gupta A., Mumovic D., K. J. Life cycle cost and carbon footprint of energy efficient refurbishments to 20th century UK school buildings. *International Journal of Sustainable Built Environment* 2014;3(1):1–17. <https://doi.org/10.1016/j.ijbsbe.2014.07.002>
- [27] Pakere I. Interviewee. Building energy audit and renovation in the Gulbene Area. [Interview]. 21 November 2019.



Fabian Andres Diaz Sanchez was born in Colombia and holds a degree in Chemical Engineering from Universidad de America in Colombia. After 10 years working in the chemical, oil, and gas sector, he moved to Latvia, where he obtained his Master's in Environmental Science with a certificate of excellence from Riga Technical University (2019), focusing on life cycle assessment. Afterwards, he was a researcher at RTU, combining his job with his PhD studies. He is currently working on life cycle sustainability assessment for different industrial sectors, supporting the construction industry on LCA scalability and automation towards environmental product declarations, digital declaration of performance, and digital product passports.