

Comparison of Co and Counter-propagating Raman Amplification in Nonlinearity Sensitive DWDM Transmission systems

Sergejs Olonkins¹, Girts Ivanovs¹

¹Institute of Telecommunications, Riga Technical University, Riga, LV-1048, Latvia
e-mail: sergejs.olonkins@rtu.lv

Nowadays a lot of research is done on the usage of fiber nonlinearity for optical amplification. Among all nonlinear optical effects stimulated Raman scattering is of particular interest, because it can be efficiently used for obtaining high signal gain combined with low amplifier noise [1].

In this report we introduced a 10Gbit/s 16 channel DWDM transmission system with NRZ-OOK modulation format and 50 GHz channel spacing, supplemented it with a single in-line distributed Raman amplifier 72 km away from the transmitter block and compared Co and Counter-propagating pumping by obtaining the maximal transmission distance.

The obtained results showed that when a Co-propagating pumping is applied transmission distance reaches 146 kilometers. To achieve this 1150 mW 1451.8 nm pump has been used. For the counter-propagating pump the achieved maximum is only 103 km. This result was obtained using a 600 mW 1451,8 nm pump.

In the case with counter propagating pump, transmitted signal is being amplified while its intensity level is still high enough to cause fiber nonlinearity to take place. Four Wave mixing produced a large amount of inter channel crosstalk, which resulted in transmission quality degradation. In the case with Co propagating pump the signal was attenuated so much, that it obtained its peak intensity only after 102 km of SMF fiber. This allowed achieving maximum small signal gain of 25.1 dB using 1150 mW pump.

If the distance between the transmitted block and the optical amplifier would be larger, we would obtain the opposite results [2], so our final conclusion is that when using Raman amplification in DWDM systems it is extremely important to take into account the intensity level of the amplified signal in order to avoid high inter channel crosstalk.

References

1. V.Bobrovs, S. Makovejs, J. Porins, G.Ivanovs, *Demonstration and Analysis of Dual Nature of Stimulated Raman Scattering in Fiber Optical Communication Systems*, Latvian Journal of Physics and Technical Sciences, 2007, No.1, P. 36-38.
2. M.N.Islam, *Raman Amplifiers for Telecommunications*, New York: Springer - Verlag, 2004 P. 213

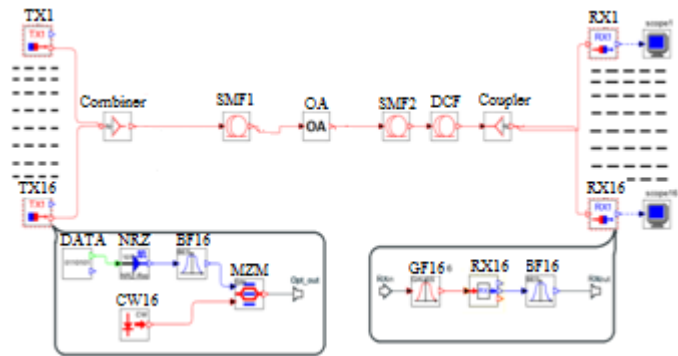

Fig.1 Simulation scheme of the 16 channel DWDM system

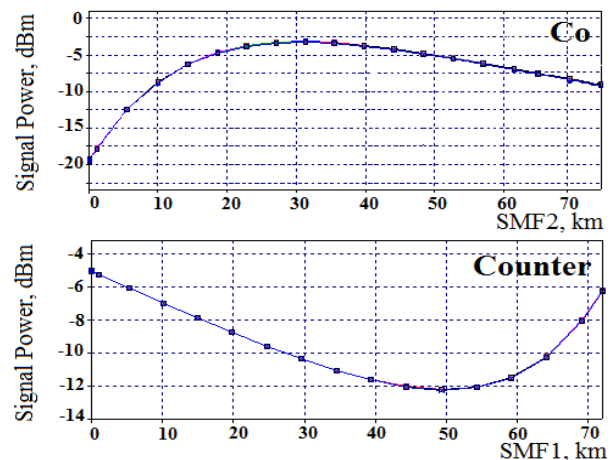

Fig.2 Signal power evolution in SMF fiber with Co (above) and Counter (below) propagating pumps