

Evaluation of Rational Parameters of Trussed Beam

Vadims Goremikins, *Riga Technical University*, Karlis Rocens, *Riga Technical University*,
Dmitrijs Serdjuks, *Riga Technical University*

Abstract. Using of subdiagonals is one of the most common methods to decrease the materials consumption of the beams in the case of increased spans. Two variants of the trussed steel beam with the span in 12 m were considered. The trussed beams consist of the top and bottom chords, struts and pillars.

Rational from the point of view of materials consumption distances from the support to the joint of the edge strut with the top and bottom chords, height of trussed beam and vertical dimension of the edge strut were evaluated by the response surface and inspection methods. The dependences of materials consumption and distances from the support to the joint of the edge strut with the top and bottom chords, height of trussed beam and vertical dimension of the edge strut were obtained as the second order polynomial equation on the base of numerical experiment.

Rational from the point of view of materials consumption structure of the trussed beam was suggested.

Keywords: trussed beam's web, materials consumption, rational parameters

INTRODUCTION

The problem of efficiency increase of steel structures is one of the most significant at the present moment [8]. The regulation of stress-strain state of bended steel structures in the design stage is one of the methods to solve the problem. The stress-strain state regulation for beams can be obtained by the using of subdiagonals. The beam is transformed in to continuous one with the complained supports in this case [3]. More rational bending moment distribution for trussed beam, in comparison with the simple one, allows decreasing of materials consumption. But the more rational bending moment distribution and materials consumption can be obtained in the case when the trussed beam possesses a rational structure.

The most widely used types of trussed beams are beams with the central pillar, beams with the vertical edge and central pillars and beams with the inclined edge struts (Fig.1) [3,10].

The comparison of the trussed beams types from the point of view of materials consumption under the action of the uniformly distributed load with intensity in 1 kN/m indicates that the most rational are types with the vertical edge struts and with the inclined edge struts. The trussed beams with the heights and spans equal to 1.5 and 12 m, correspondingly, were considered.

In this connection, the aim of the paper is to develop rational from the point of view of materials consumption structure of trussed beams with the vertical edge and central pillars and with the inclined edge struts and vertical central pillar. The dependences of the main geometric parameters of the trussed beams and materials consumption also must be obtained.

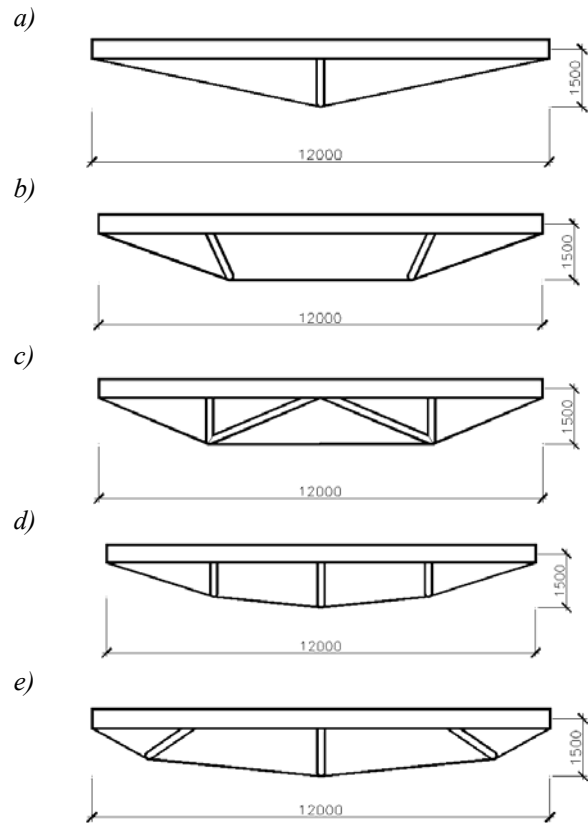

Fig.1. Types of the trussed steel beams: a) – type with the central pillar; b) – type with the inclined edge struts; c) – type with the inclined central struts and edge pillars; d) – type with the vertical edge and central pillars; e) – type with the inclined edge struts and vertical central pillar.

SOLUTION OF THE PROBLEM

The trussed steel beams with the vertical edge and central pillars and with the inclined edge struts and vertical central pillar were considered as the objects of investigation. The spans of the beams were equal to 12 m [3]. The development of rational structures of trussed beams was joined with the determination of it rational, from the point of view of materials consumption, geometric parameters. The main geometric parameters of trussed beam with the vertical edge and central pillars are heights of beam and edge pillar and distance from the support to the joint of edge pillar with the top chord (Fig.2).

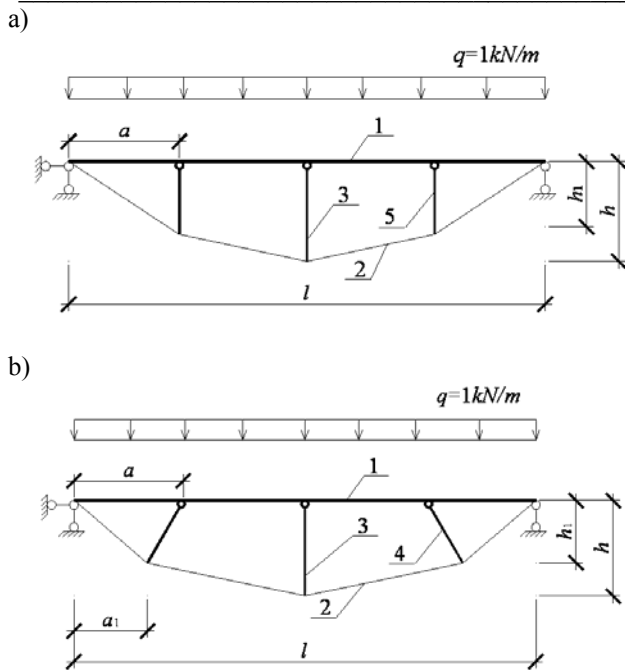

Fig.2. Design schemes of the trussed steel beams: a) – variant with the vertical edge pillar; b) – variant with the inclined edge struts; 1 – top chord; 2 – bottom chord; 3 – central pillar; 4 – edge strut; 5 – edge pillar; a - distance from the support to the joint of the edge strut with the top chord; a₁ - distance from the support to the joint of the edge strut with the bottom chord; h – height of the trussed beam; h₁ – vertical dimension of the edge strut or edge pillar.

The main geometric parameters of trussed beam with the inclined edge struts and vertical central pillar are distances from the support to the joint of the edge strut with the top and bottom chords, height of trussed beam and vertical dimension of the edge strut (Fig.2).

The beams were considered under the action of uniformly distributed load with intensity in 1 kN/m. The bottom chord is not prestressed. Steel with the point of yield in 280 MPa was considered as material of top chord, struts and pillars. Steel cable on the base of the wire with tensile strength in 1960 MPa and modulus of elasticity in $1.7 \cdot 10^5$ MPa was considered as the material of bottom chord.

Rational from the point of view of materials consumption main geometric parameters of trussed beams with the vertical edge and central pillars and with the inclined edge struts and vertical central pillar (Fig.2) were evaluated by the response surface method [6]. The dependence of the materials consumption on the heights of the beam, edge pillar and distance from the support to the joint of edge pillar with the top chord (Fig.2. a)), was evaluated in the form of second order polynomial equations (1) [7,15]:

$$P_a = b_0 + b_1 \cdot h + b_2 \cdot a + b_3 \cdot h_1 + b_{11} \cdot h^2 + b_{12} \cdot h \cdot a + b_{13} \cdot h \cdot h_1 + b_{22} \cdot a^2 + b_{23} \cdot a \cdot h_1 + b_{33} \cdot h_1^2 \quad (1)$$

The dependence of the materials consumption on the distances from the support to the joint of the edge strut with

the top and bottom chords so as height of trussed beam and vertical dimension of the edge strut (Fig.2. b)) was evaluated by the same approach, as the equation (1):

$$P_b = b_0 + b_1 \cdot h + b_2 \cdot a + b_3 \cdot a_1 + b_4 \cdot h_1 + b_{11} \cdot h^2 + b_{12} \cdot h \cdot a + b_{13} \cdot h \cdot a_1 + b_{14} \cdot h \cdot h_1 + b_{22} \cdot a^2 + b_{23} \cdot a \cdot a_1 + b_{24} \cdot a \cdot h_1 + b_{33} \cdot a_1^2 + b_{34} \cdot a_1 \cdot h_1 + b_{44} \cdot h_1^2 \quad (2)$$

The coefficients of equations (1) and (2) were determined on the base of numerical experiment. The experiment was joined with the determination of internal forces, which acts in the elements of the truss when the uniformly distributed load is applied. The dimensions of elements cross-sections were determined then on the base of obtained internal forces.

The elements of the top chord, struts and pillars are subjected to the compression with the bending. The type of cross-sections of top chord, struts and pillars was rectangular to prevent influence of the assortment. The height/width relations were equal to 2 for the elements of top chord and to 1 for the struts and pillars.

The bottom chord is tensioned and its cross-sectional area was determined by the equation (3):

$$A \geq \frac{1.6 \cdot N}{k \cdot R_{tm}} \quad (3)$$

where: A – cross-sectional area of the bottom chord; N – force acting in the bottom chord; R_{tm} – tensile strength of the wire; k – coefficient, taking into account the drop in the breaking force of the cable, caused by the inhomogeneity of stress distribution; 1.6 – reliability index of the material.

The coefficient k, taking into account the drop in the breaking force of the cable, caused by the inhomogeneity of stress distribution, was equal to 0.75 [16].

Rational values of the heights of edge and central pillars and distance from the support to the joint of edge pillar with the top chord were determined by the system of equations (4) and then were precised by the inspection.

$$\begin{cases} \frac{\partial P_a}{\partial h} = b_1 + b_{12} \cdot a + b_{13} \cdot h_1 + 2 \cdot b_{11} \cdot h = 0, \\ \frac{\partial P_a}{\partial a} = b_2 + b_{12} \cdot h + b_{23} \cdot h_1 + 2 \cdot b_{22} \cdot a = 0, \\ \frac{\partial P_a}{\partial h_1} = b_3 + b_{13} \cdot h + b_{23} \cdot a + 2 \cdot b_{33} \cdot h_1 = 0. \end{cases} \quad (4)$$

Rational values of the heights of the distances from the support to the joint of the edge strut with the top and bottom chords, height of trussed beam and vertical dimension of the edge strut were evaluated by the inspection.

Minimum materials consumption was determined on the base of obtained rational values of trussed beams geometric parameters. Second limit state was not taken into account.

NUMERICAL RESULTS FOR TRUSSED BEAM WITH THE
VERTICAL EDGE PILLARS

Twenty seven variants of trussed beam with the vertical edge pillars were analysed using the computer program LIRA 9.4. The variants were differed by the values of heights of the beam and central pillars and distance from the support to the joint of edge pillar with the top chord. The heights of the edge pillar change within the limits from 1 to 4 m. The relation of the edge pillars height to the beams height, changes within the limits from 0.65 to 0.85. The distance from the support to the joint of edge pillar with the top chord of the trussed beam changes within the limits from 2.6 to 3.2 m.

Coefficients of second order polynomial equation, which describe the dependences of material consumption on the heights of the beam and edge pillars and distance from the support to the joint of edge pillar with the top chord, are given in the Table 1.

The dependence of materials consumption on the height of the beam and distance from the support to the joint of edge pillar with the top chord of the trussed beam is shown in Fig.3. The height of edge pillar is equal to three quarter of central pillars height.

TABLE 1
Coefficients of the equation (1)

Designation of coefficients	Values of coefficients
b_0	387.0540
b_1	-3.6141
b_2	16.2759
b_3	-905.5000
b_{11}	2.4378
b_{12}	-2.4778
b_{13}	-4.4444
b_{22}	53.2778
b_{23}	-422.7780
b_{33}	1404.3300

The dependence indicates that materials consumption changes within the limits from 44.270 to 77.170 kg.

The dependence of materials consumption on the heights of the beam and edge pillar is shown in Fig.4. The dependence was obtained when the distance from the support to the joint of edge pillar with the top chord of the trussed beam was constant and equal to 2.9 m. The shapes of obtained dependences indicate that the rational values of the heights of edge and central pillars and distance from the support to the joint of edge pillar with the top chord can be determined by the system of equations (4) and the obtained values will be within the limits of the experiments field.

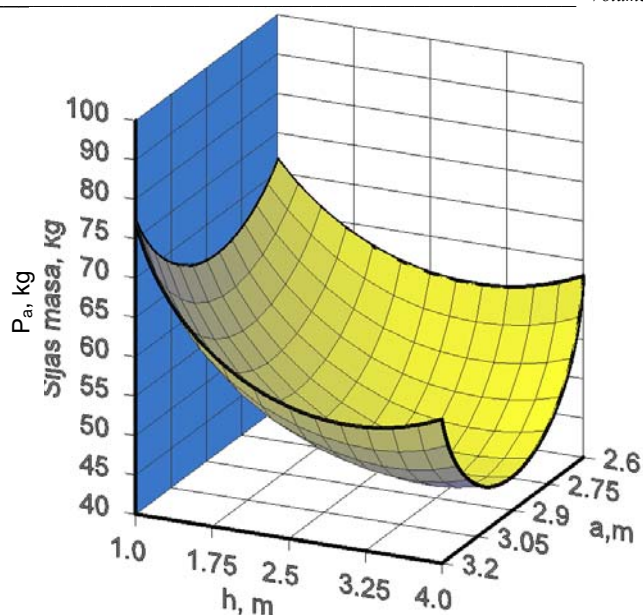

Fig.3. The dependence of materials consumption on the heights of the beam and distance from the support to the joint of edge pillar with the top chord of the trussed beam: P_a – materials consumption of trussed beam with the vertical edge pillar; h – height of the beam; a – distance from the support to the joint of edge pillar with the top chord. The height of edge pillar is equal to three quarter of the beams height.

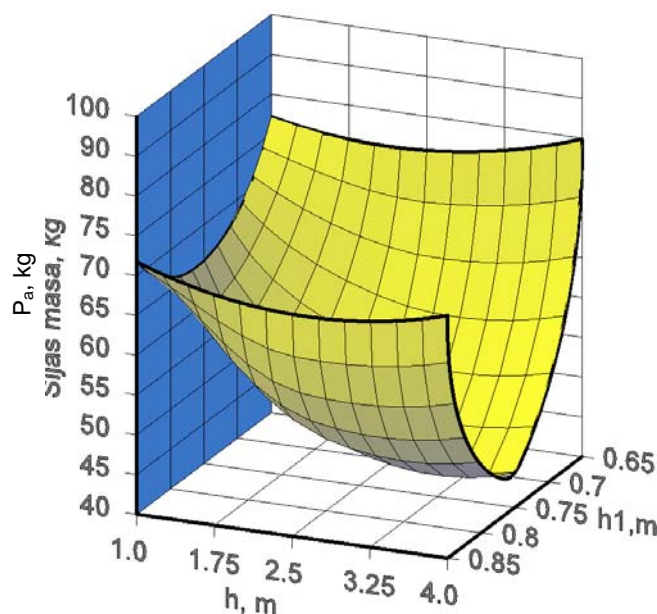

Fig.4. The dependence of materials consumption on the heights of the beam and edge pillar: P_a – materials consumption of trussed beam with the vertical edge pillar; h_1 – height of the edge pillar. Other designations as in Fig.3. The distance from the support to the joint of edge pillar with the top chord of trussed beam is equal to 2.9 m.

The dependence indicates that materials consumption changes within the limits from 44.270 to 85.650 kg.

The rational from the point of view of materials consumption values of height of the beam and distance from the support to the joint of edge pillar with the top chord are equal to 2.560 and 2.740m, respectively. The rational value of edge pillars height is equal to 1.820 m. Minimum value of materials consumption is equal to 42.97 kg.

NUMERICAL RESULTS FOR TRUSSED BEAM WITH THE INCLINED EDGE STRUTS

The rational from the point of view of materials consumption values of main geometric parameters of trussed beam with the inclined edge struts were evaluated by the inspection. The distances from the support to the joint of the edge strut with the top and bottom chords changes with the step 0.02 m from 2.5 to 2.9 m and from 1.2 to 2 m, respectively. The heights of the beam and the vertical dimension of the edge strut changes with the step 0.02m, from 1.9 to 2.5 m and from 1.25 to 1.65 m, respectively.

The graphs of the dependence (2) are shown in Fig.5 and 6. The dependence of materials consumption on the height of the beam and distance from the support to the joint of the edge strut with the top chord of trussed beam is shown in Fig.5. The graphs were obtained at the fixed values of vertical dimension of the edge strut and distances from the support to the joint of the edge strut with the bottom chord. The vertical dimension of the edge strut was constant and equal to 1.45 m. The distances from the support to the joint of the edge strut with the bottom chord was fixes at the level of 1.20 m.

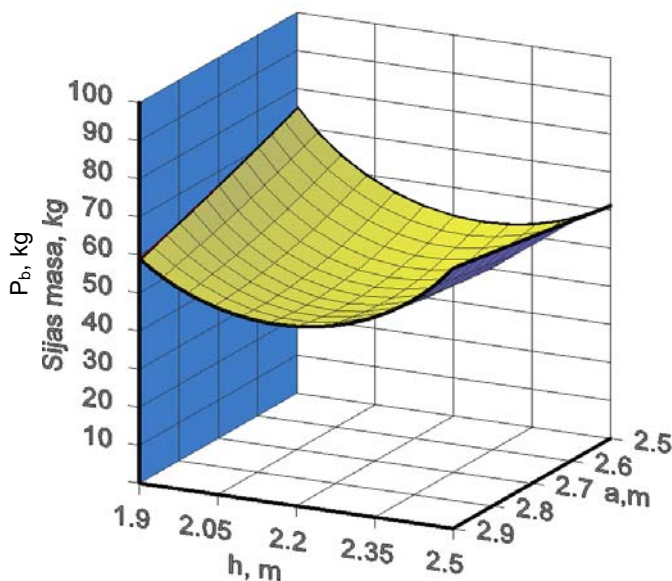

Fig.5. The dependence of materials consumption on the height of the beam and distance from the support to the joint of the edge strut with the top chord of trussed beam with the inclined edge struts: P_b – materials consumption of trussed beam; h - height of the beam; a - distance from the support to the joint of the edge strut with the top chord of trussed beam; The vertical dimension of the edge strut was equal to 1.45 m. The distances from the support to the joint of the edge strut with the bottom chord was equal to 1.20 m.

The dependence of materials consumption on the distances from the support to the joint of the edge strut with the top

chord and vertical dimension of the edge strut is shown in Fig.6.

The rational, from the point of view of materials consumption, values of distances from the support to the joint of the edge strut with the top and bottom chords are equal to 2.840 and 1.910 m, respectively. The rational values of beams height and vertical dimension of the edge strut are equal to 2.480 and 1.630 m, respectively. Minimum value of materials consumption is equal to 40.919 kg.

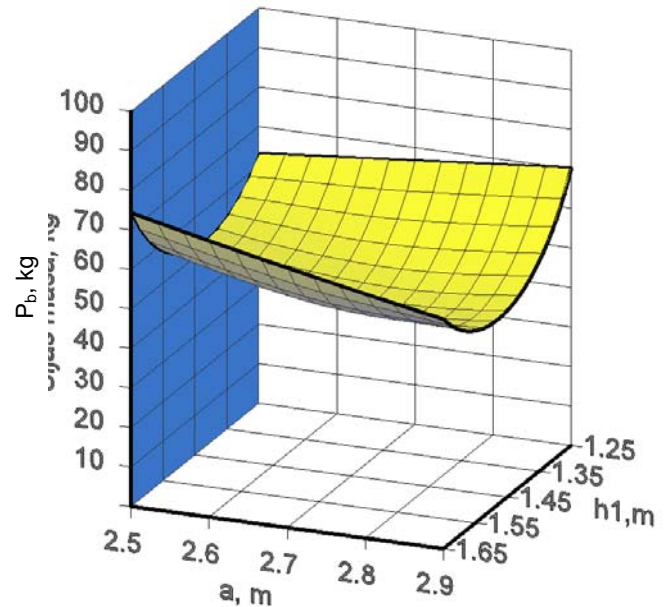

Fig.6. The dependence of materials consumption on the distances from the support to the joint of the edge strut with the top chord and vertical dimension of the edge strut: h_1 - vertical dimension of the edge strut. Other designations as in Fig.5. The distance from the support to the joint of the edge strut with the bottom chord of trussed beam is equal to 2 m. The height of the beam was equal to 2.2 m.

So, using of inclined edge struts instead of vertical pillars allows to decrease materials consumption of trussed beam by 5%. The inclined edge struts allows to decrease more effectively the values of bending moments, which act in the top chord of trussed beam under the action of vertical uniformly distributed load.

CONCLUSIONS

The rational from the point of view of materials consumption structure of trussed beams with the vertical edge and central pillars and with the inclined edge struts and vertical central pillar was suggested.

It was shown, that the rational from the point of view of materials consumption values of height of the beam and distance from the support to the joint of edge pillar with the top chord of trussed beams with the vertical edge and central pillars, are equal to 2.560 and 2.740m, respectively. The rational value of edge pillars height is equal to 1.820 m. Minimum value of materials consumption is equal to 42.97 kg.

The rational from the point of view of materials consumption values of distances from the support to the joint of the edge strut with the top and bottom chords of trussed

beams with the inclined edge struts and vertical central pillar, are equal to 2.840 and 1.910 m, respectively. The rational values of the beams height and vertical dimension of the edge strut are equal to 2.480 and 1.630m, respectively. Minimum value of materials consumption is equal to 40.919 kg.

It was stated, that using of inclined edge struts instead of vertical pillars allows to decrease materials consumption of trussed beam by 5%.

REFERENCES

1. **Goremikin, V., Serdjuks, D.** Rational Structure of Trussed Beam. *In: The 10th International Conference "Modern Building Materials, Structures and Techniques"*, Vilnius, May 19-21, 2010. Proceedings. Vilnius, Vilnius Gediminas Technical University, p. 613–618.
2. **Goremikin, V., Rocens, K., Serdjuks, D.** Rational Structure of Composite Trussed Beam. *In: The 16th International Conference "Mechanics of composite materials"*, Jurmala, May 24-28, 2010. Abstracts. Riga, Institute of Polymer Mechanics, 2010, p. 75.
3. **Gogol, M.** Shaping of Effective Steel Structures. *Scientific proceedings of Rzeszow Technical University*, Rzeszow, Rzeszow Technical University, 2009, No 264, p. 43-56.
4. **Fletcher, R.** *Practical methods of optimization, 2nd edition*. London: John Willey & Sons Inc., 2000, 451 p.
5. **Montgomery, D. C.** *Design and analysis of experiments, 5th edition*. New York: John Willey & Sons Inc., 2001, 697 p.
6. **Myers, R. H., Montgomery D.C.** *Response Surface Methodology. Process and Product Optimization Using Design Experiment, 2nd edition*. New York: John Willey & Sons Inc. 798 p.
7. **Serdjuks, D., Rocens, K.** Decrease the Displacements of a Composite Saddle-Shaped Cable Roof. *Mech. Compos. Materials*, 2004, Vol. 40, No 5.
8. **Shen, Z.Y., Li, G.Q., Zhang, Q.L.** Advances in steel structures. *In: Fourth International Conference*, Shanghai, China, June 13-15, 2005
9. **Барабаш, М., Лазнюк, М., Мартынова, М., Пресняков, Н.** *Современные технологии расчета и проектирования металлических и деревянных конструкций*. Москва: Издательство Ассоциации строительных вузов, 2008, 328 с.
10. **Беленя, Е.** *Стальные конструкции: Спецкурс*. Москва: Стройиздат, 1991, 687 с.
11. **Ведеников, Г.** *Металлические конструкции: Общий курс*. Москва: Стройиздат, 1998, 760 с.
12. **Городецкий, А., Евзоров, И.** *Компьютерные модели конструкций*. Киев: Факт, 2005, 344 с.

13. **Ермолов, В.** *Инженерные конструкции*. Москва: Высшая школа, 1991, 408 с.
14. **Михайлов, В.** *Предварительно напряженные комбинированные и вантовые конструкции*. Москва: АСВ, 2002, 255 с.
15. **Спирidonov А.** *Планирование эксперимента при исследовании технологических процессов*. Москва: Машиностроение, 1981, 184 с.
16. **Трушев А.** *Пространственные металлические конструкции*. Москва: Стройиздат, 1983, 216 с.

Vadims Goremikins, M.Sc.Ing., Assistant.

Vadims Goremikins was born in Riga on 6th February 1986. He is a doctoral study student. He received his professional master degree (M.Sc.Ing) in Civil Engineering from the Riga Technical University, Latvia in 2009. He graduated as a civil engineer and holds a professional bachelor degree in civil engineering (B.Sc.Ing) from the Riga Technical University on 2008.

He currently works as Assistant of scientific work at the Riga Technical University, and as Assistant in the Building Structures department at the Riga Technical University. He was Internal Control Specialist, Guarantee repair Specialist, Civil engineer assistant at "MTK Construction" Ltd.

He is a member of the Association of Latvian Young Scientists.

Address: 1 Kalķu Street, Riga LV-1658, Latvia, E-mail: goremikin@inbox.lv

Karlis Rocens is a professor of structural engineering and director of the Institute of Structural Engineering and reconstruction at the Riga Technical University, Latvia. He is a Full member of Latvian academy of sciences and participant from Latvia in COST C25 "Sustainability of Constructions: Integrated Approach to Life Time Structural Engineering". Author of 5 monographs and more than 250 scientific articles. His research interests include the modern structures, technological mechanics of wood and composite materials and structural material science.

Address: 1 Kalķu Street, Riga LV-1658, Latvia, E-mail: rocensk@latnet.lv

Dmitrijs Serdjuks, Civil Engineer, *Dr.sc.ing.* (2001), asoc. prof.. RTU Faculty of Building and Civil Engineering (1995). M.sc.ing. (1997). RTU B. F. Division of Building Constructions, assistant (1998-2001), lecturer (2001-2004), docent (2004-2008), associated professor (since 2008).

Subjects: metal structures, timber and plastic structures, structural optimization. Investigations in field of steel and composite structures. Publications: ~ 50 scientific and methodological works.

Address: 1 Kalķu Street, Riga LV-1658, Latvia,

E-mail: dmitrijs.serdjuks@rtu.lv

Vadims Goremikins, Karlis Rocens, Dmitrijs Serdjuks. Šprengelsijas racionālo parametru novērtēšana

Šprengļu izmantošana ļauj samazināt sijas materiālu patēriņu lielo laidumu gadījumā. Apskatīti divi šprengelsijas varianti ar laidumu 12 m, kas atšķiras ar režģojuma shēmu. Šprengelsijas sastāv no augšējās un apakšējās joslas, statiem un atgāžņiem. Tērauds ar plūstamības robežu vienādu ar 280 MPa pieņemts kā augšējās joslas un režģojuma elementu materiāls. Apakšēja josla ir iepriekš nesaspriegtais vantis ar atsevišķo stiepli perējošo pretestību vienādu ar 1960 MPa. Racionālie no materiālu patēriņa viedokļa augšējās un apakšējās joslas paneļu garumi, šprengelsijas augstums un mālēja atgāžņa vertikālais izmērs, novērtēti eksperimenta gaitā. Sakarības starp materiālu patēriņu, augšējās un apakšējās joslas paneļu garumiem, šprengelsijas augstumu un mālēja atgāžņa vertikālo izmēru, noteikta uz skaitliskā eksperimenta bāzes. Sakarības veids – otras pakāpes polinoms.

Piedāvāta šprengelsijas racionāla no materiālu patēriņa viedokļa konstrukcija. Parādīts, ka slīpo statņu izmantošana ļauj samazināt šprengelsijas materiāla patēriņu par 5% salīdzinājuma ar šprengelsiju ar vertikāliem statiem.

Вадим Горемыкин, Карлис Роцэнс, Дмитрий Сердюк. Оценка рациональных параметров шпренгельной балки

Использование шпренгелей является одним из наиболее рациональных способов уменьшить расход материала для балок в случае больших пролетов. Рассмотрено два варианта шпренгельной балки пролетом 12 м, отличающиеся схемами решеток. Сталь с пределом текучести в 280 МПа рассмотрена в качестве материала элементов верхнего пояса и решетки. Нижний пояс представляет собой вант без предварительного напряжения, выполненный из проволоки с пределом прочности в 1960 МПа.

Рациональные, с точки зрения расхода материалов, длины панелей верхнего и нижнего поясов, высота шпренгельной балки и вертикальный размер крайнего раскоса, определены при помощи численного эксперимента. Численный эксперимент проведен при помощи методов поверхности отклика и перебора. Получены зависимости между расходом материалов, длинами панелей верхнего и нижнего поясов, высотой шпренгельной балки и вертикальным размером крайнего раскоса. Форма полученных зависимостей – полином второго порядка.

Предложена рациональная конструкция шпренгельной балки. Показано, что использование наклонных распорок позволяет уменьшить расход материала шпренгельной балки на 5% по сравнению с шпренгельной балкой с вертикальными распорками.