

## Realization of up to 10 Gbit/s Spectrum Sliced Optical Access System

S. Spolitis<sup>1</sup>, G. Ivanovs<sup>1</sup>

<sup>1</sup>Riga Technical University, Institute of Telecommunications, Riga, Latvia

E-mail: sandis.spolitis@rtu.lv

The growing number of Internet users and bandwidth-driven applications, such as online gaming, streaming video, telemedicine, video conferencing and others bring various challenges for network operators and force them to migrate toward new architectures [1, 2]. Spectrum-sliced wavelength-division-multiplexed passive optical network (SS-WDM PON) can be cost effective solution to satisfy the growing global demand for transmission capacity in next generation fiber optical access networks [3]. The strength of spectrum-sliced WDM-PON technology is use of one common broadband seed light source and its ability to locate electronics and optical elements in one central office (CO), in such a way simplifying the architecture of fiber optical network (see Fig. 1).

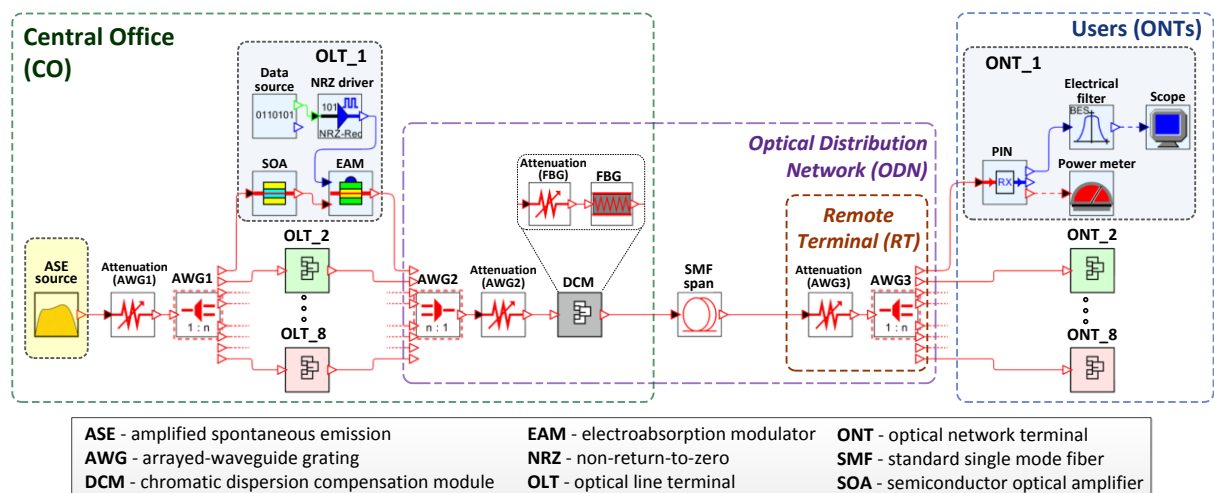

**Fig.1.** Setup of spectrum-sliced system with data transmission speed up to 10 Gbit/s per channel.

In this research we propose 8-channel WDM-PON access system where optical transmission is realized by slicing spectrally-uniform ASE source, which is shared by multiple users. The broadband ASE light source is constructed from two EDFAs combined in cascaded mode, each after another. Proposed system is built on the ITU-T 100 GHz frequency grid and is capable to provide downstream data transmission over 20 km SMF fiber span with defined bit error rate  $BER < 10^{-12}$ . It is achieved by using additional chromatic dispersion compensation module (before fiber optical span) and semiconductor optical amplifier (in each optical line terminal) for excess intensity noise suppression.

### References

- [1] M. Mahloo et al., "Towards Reliable Hybrid WDM/TDM Passive Optical Networks," IEEE Commun. Mag., Vol. 52, no. 2, pp. 14-23, (2014).
- [2] V. Bobrovs et al., "Latency causes and reduction in optical metro networks," Proc. SPIE Vol. 9008, 90080C, San Francisco (2013).
- [3] G. Ivanovs et al., "Performance improvement of spectrum-sliced passive optical network," in Proc. of Progress in Electromagnetics Research Symposium (PIERS), pp. 308-311, (2013).